

Chilled Ceiling Elements

Type WK-D-WF

Convective chilled ceilings providing excellent visual results



TROX[®] TECHNIK

Contents · Description

Description _____	2
Construction · Dimensions _____	3
Details · Accessories _____	4
Installation Examples · Technical Data _____	5
Order Details _____	6



Description

Chilled ceiling elements Type WK-D-WF can be used as an exposed system or combined with grid ceilings to provide a convective chilled ceiling installation.

The proportion of convection is approximately 70% and that of radiation approximately 30%. Due to the high proportion of convection very high internal loads can be dealt with hence demonstrating to particularly good effect the advantages of water as the medium for this purpose.

Where an additional open grid ceiling is suspended underneath, the effective open area should be as large as possible to maintain the high efficiency of the convective chilled ceiling.

Depending on the structural conditions and the maximum required water pressure drop, the chilled elements are provided as large units or fitted together in groups.

Rigid piping (soldering) or push fit flexible hose connections can be provided for joining the individual chilled elements together or connecting them to the header system. The flexible hose connection is easy and inexpensive to fit.

Additional soldering is not required if flexible hoses are used.

After assembly the whole system should be tested for leaks. The tests can be carried out with air or water depending on the chilled facilities available.

As with all chilled ceilings the chilled water flow temperature is selected to prevent it falling below the room dew point.

Construction · Dimensions

Construction

Chilled elements Type WK-D-WF comprise 170 mm wide wave-shaped flanged slats. In the standard construction the spacing between the blades is 30 mm, giving an overall modular dimension of 200 mm.

The copper pipe meanders are pressed into the slats, guaranteeing an optimum thermal conducting contact between the blade and the copper tube.

The chilled elements are suspended on-site from the ceiling slab. There are flanges on the chilled elements for this purpose. None of the copper tubing is visible from below and a symmetrical visual effect is achieved.

The chilled elements can be used as a continuous tile ceiling or as freely suspended chilled elements. An aesthetically pleasing effect can also be created in combination with grid ceilings and/or plasterboard ceilings. Refer to Trox for further details.

The chilled elements can be suspended from the ceiling slab by means of threaded rods or Nonius hangers, or alternatively by suitable substructure systems, thus guaranteeing easy installation.

Dimensions

The chilled elements vary in length. The width of the elements can be varied as multiples of modular dimension 200 mm.

Maximum length of the element: 4000 mm
 Maximum width of the element: 1400 mm
 Weight: 14 ... 28 kg/m²
 (depending on construction)

Dimensions

L x B _N Combinations are dependent on water pressure drop						
Number of panels	2	3	4	5	6	7
L / B _N (mm)	400	600	800	1000	1200	1400
1000	x	x	x	x	x	x
1500	x	x	x	x	x	x
2000	x	x	x	x	x	x
2500	x	x	x	x	x	x
3000	x	x	x	x	x	
3500	x	x	x	x		
4000	x	x	x			

Length: Variable in 10 mm increments
 B_N: Nominal width
 B: (B = B_N-30 mm)

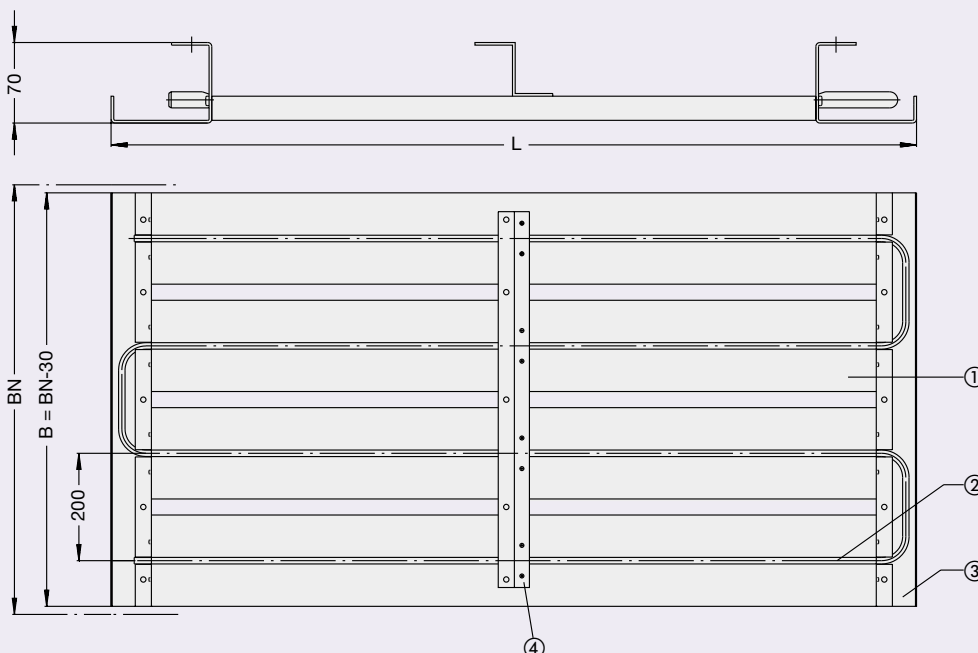

- ① Blade
- ② Cu meander
- ③ Cover/Installation flange
- ④ Additional z-angle (longer length cooling elements)

Water Circulation

The chilled elements can be assembled individually or in groups for water circulation. The number of elements combined depends on the dimensions chosen and on the installation site. This gives rise to corresponding water pressure drop.

Where there are several group connections the elements must be installed using a reverse return system as this is the only way to obtain uniform water circulation.

Flexible Hoses

The use of a push fit flexible hose is a particularly easy method for joining the elements together and for connecting to the flow and return headers. These hoses are made from special plastic with woven braided sleeve and push fit coupling on either end. The push fit connection, which is both simple and inexpensive, requires no additional tools.

The push fit coupling is suitable for a 12 mm diameter pipe. The ends of the flow and return headers must also be suitable for the push fit coupling.

Pipe Layout Diagram

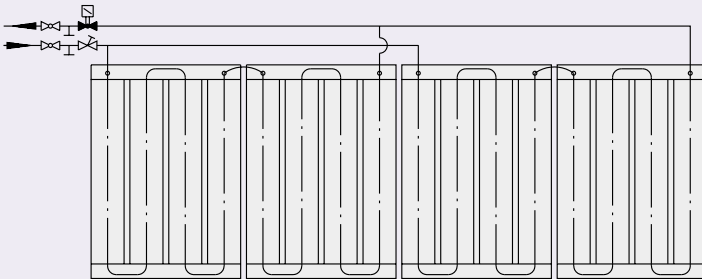

Flexible Hose

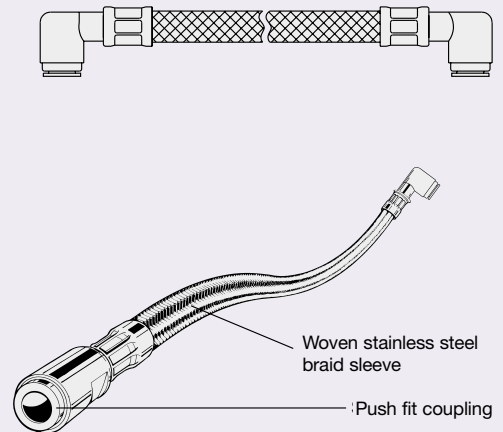

Woven stainless steel braid sleeve

Push fit coupling

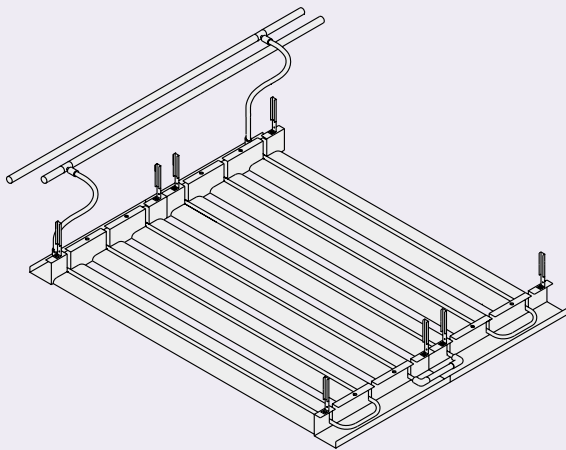

Ceiling slab

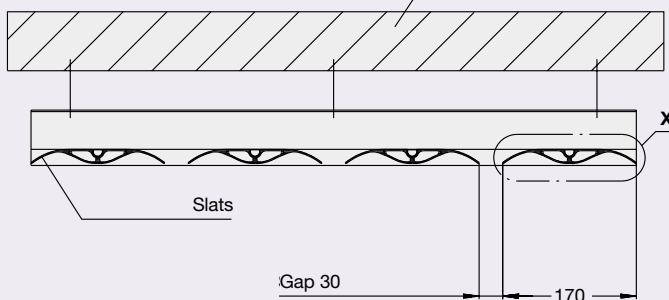

Slats

Gap 30

170

Meanders

Either flexible connection with hoses or rigid piping (90° bend, internal diameter = 12 mm)

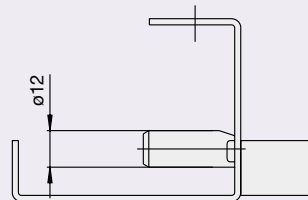

Detail X
Slats

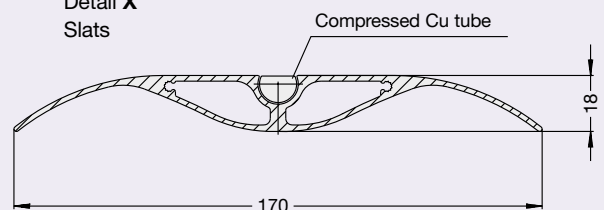

Compressed Cu tube

18

170

Installation Example · Technical Data

Cooling Performance

In convective chilled ceilings with chilled elements type WK-D-WF the cooling performance achieved is significantly higher than that of normal radiant continuous chilled ceiling (proportion of radiation approx. 30 %, proportion of convection approx. 70 %).

Because of the many possible uses of the chilled ceiling systems there can be – depending on the installation site – variation in cooling performance.

The specific cooling performance given in the installation examples listed correspond to the performance measurements to DIN 4715.

Where an additional grid ceiling is suspended underneath, the specific cooling performance is reduced according to the free cross-section available. The use of different ventilation systems and arrangements will increase the specific cooling performance by 8-15%.

In the case of specific project applications performance can be demonstrated in the Trox test facilities to the requirements of DIN 4715. Alternatively or in addition full space mock up testing can be undertaken using test rooms including the effects of the proposed ventilation system.

Please contact Trox for further details.

The specific cooling performance mentioned relates to the element module dimensions, without cover/ installation flange.

Examples

A) Installation as a chilled closed ceiling system

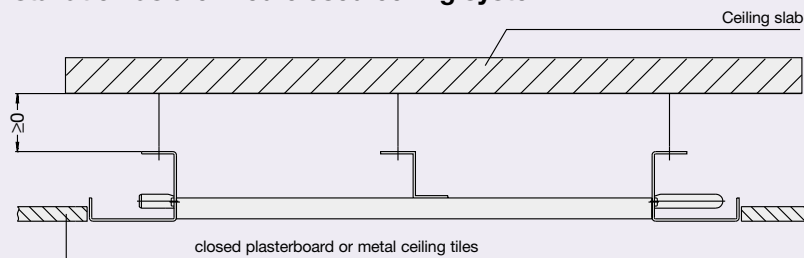

Performance data to DIN 4715

$$\dot{q} = 136 \text{ W/m}^2$$

B) Installation as under A) but with continuous gap

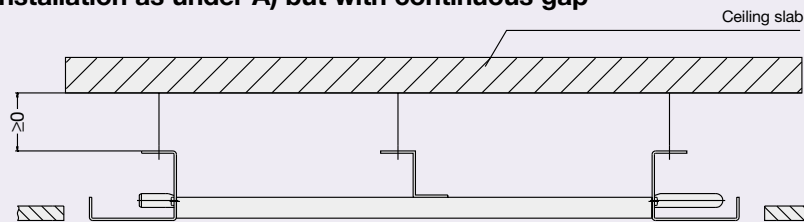

Performance data to DIN 4715

$$\dot{q} = 150 \text{ W/m}^2$$

C) Installation as free standing chilled elements

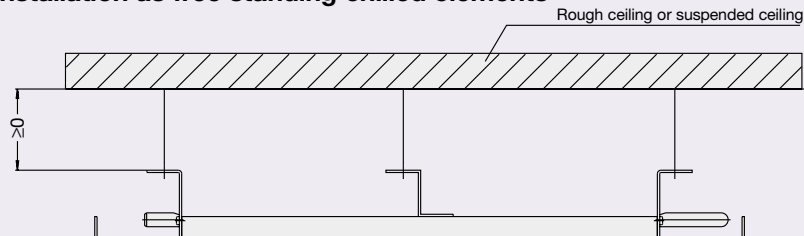

Performance data to DIN 4715

$$\dot{q} = 153 \text{ W/m}^2$$

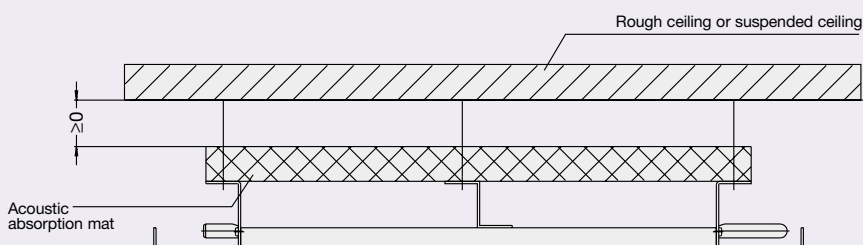

Performance data to DIN 4715

$$\dot{q} = 145 \text{ W/m}^2$$

Order Details

Specification Text

Chilled ceiling elements Type WK-D-WF are suitable as an exposed installation below the ceiling slab or in combination with open suspended ceilings. They can also be built into metal or plasterboard ceilings. Approximately 70 % of internal loads are dealt with by convection and approximately 30 % by radiation.

The chilled elements comprise horizontal flanged slats arranged in 200 mm modules which are held together by means of fitting/covering angles to form panels.

Copper tubes are pressed into the flanges to form continuous meanders. The meanders can be connected by solder pipes (internal diameter 12 mm) or hoses (external diameter 12 mm) can be used for push fit connection.

Materials

Aluminium slats, copper meander. Covering and fitting angle in galvanized sheet steel, with entire surface powder-coated to RAL 9010 or to choice.

The flexible hoses available as an accessory are diffused oxygen-tight to DIN 4726/4727 with stainless steel braided sleeve and push fit connectors on both ends.

The hoses are available with push fit connectors which are either straight or with a 90° elbow.

Order Code

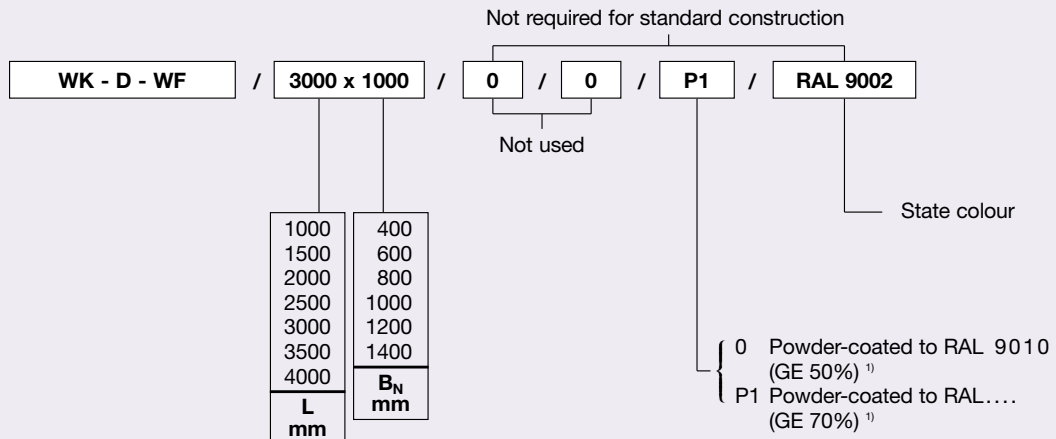

1) GE = Gloss level

Accessory

Flexible hose

Flexible hose with 90° elbow and straight connection (for connecting chilled element and header)

FS-90/1-500 mm

FS-90/1-700 mm

Flexible hose with two 90° elbows (cooling element/header)

FS-90/2-205 mm

Order Example

Manufacture: TROX

Type: WK-D-WF / 3000 x 1000/P1/RAL 9002

Accessory: FS-90/1-700 mm