

# Weather-Resistant Louvres

Type WG · AWG · WGE · AWK · WG-F



**TROX<sup>®</sup>** TECHNİK

# Contents · Description

---

Description .....	2
Construction .....	3
Installation Details .....	5
Standard Sizes · Drilling Details .....	7
Product Range .....	8
Technical Data .....	9
Order Details .....	10



Weather-resistant louvres give good protection against the direct ingress of rain, leaves and birds. Because of their design, they cannot prevent the entry of slight quantities of water under certain conditions. Virtual weather-proofing can only be achieved by the subsequent use of eliminators.



## Type WG · AWG · WGE · AWK

### WG

- Frames and blades of formed, galvanised sheet steel
- Wire mesh screen from galvanised steel, mesh size 20 x 20 mm
- Flange drilled as standard

### AWG

- Frames and blades of extruded aluminium sections
- Wire mesh screen from galvanised steel, mesh size 20 x 20 mm
- Flange drilled as standard

### WGE

- Frames, blades and wire mesh screen (mesh size 20 x 20 mm) all in stainless steel type No. 1.4301
- Flange drilled as standard

### AWK

- Frames and blades of extruded aluminium sections, natural anodised (E6-C-0)
- Wire mesh screen of galvanised steel, mesh size 6 x 6 mm
- Flange drilled as standard

## Type WG · AWG · WGE

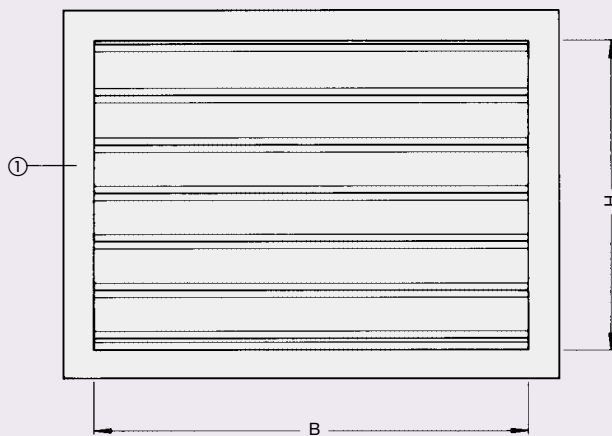

Free cross-section approx. 60 %, based on  $B \times (H - 0.085 \text{ m})$

WG  
WGE

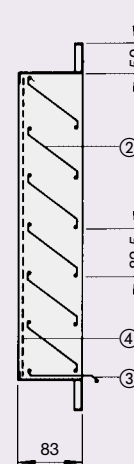

AWG

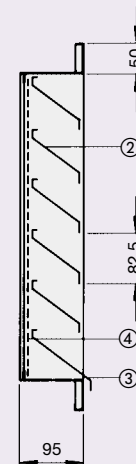

## Type AWK

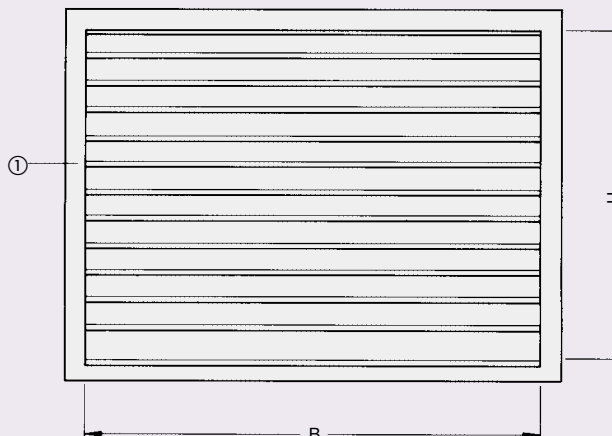

Free cross-section approx. 60 %, based on  $B \times (H - 0.028 \text{ m})$

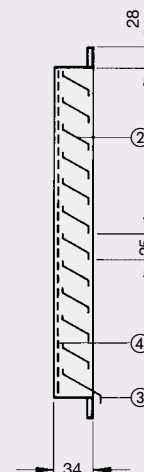

- ① Frame
- ② Blade
- ③ Bottom blade
- ④ Wire mesh screen

# Construction

## Type WG-F

### WG-F (steel construction)

- Blades and support mullion in formed galvanised sheet steel; the mullion is also powder coated black (RAL 9005)
- Mullion is drilled at side and rear for connecting louvre sections together or connecting to site support structure
- Wire mesh screen from galvanised steel, mesh size 20 x 20 mm

### WG-F (aluminium construction)

- Blades of extruded aluminium sections
- Mullion in formed galvanised sheet steel; powder coated black (RAL 9005)
- Mullion is drilled at side and rear for connecting louvre sections together or connecting to site support structure
- Wire mesh screen from galvanised steel, mesh width 20 x 20 mm

## Type WG-F

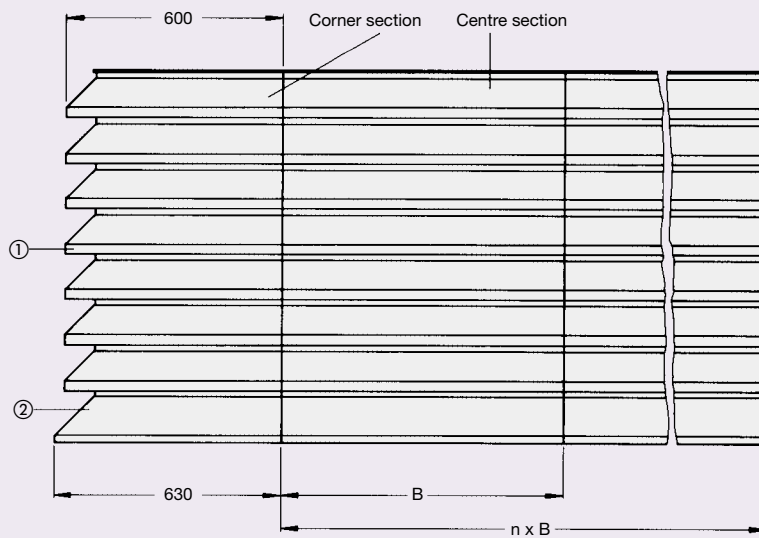

n = Number of centre sections  
free cross-section approx. 50% based on B x (H - 0.125 m)

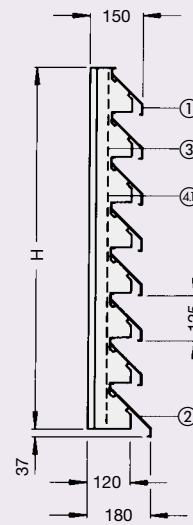

### Corner Section

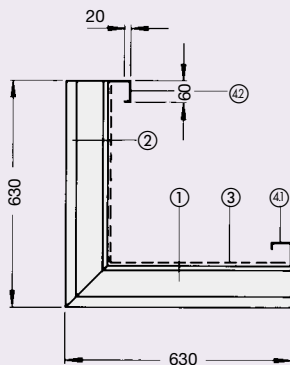

Dimensions = 600 x H

- ① Blade
- ② Bottom blade
- ③ Wire mesh screen
- ④ Right hand mullion
- ④ Left hand mullion

Components ① – ④ are supplied in kit form for site assembly.  
Fixings are included in the scope of supply.

# Installation Details

## Masonry Subframe

### Type WG · AWG · WGE

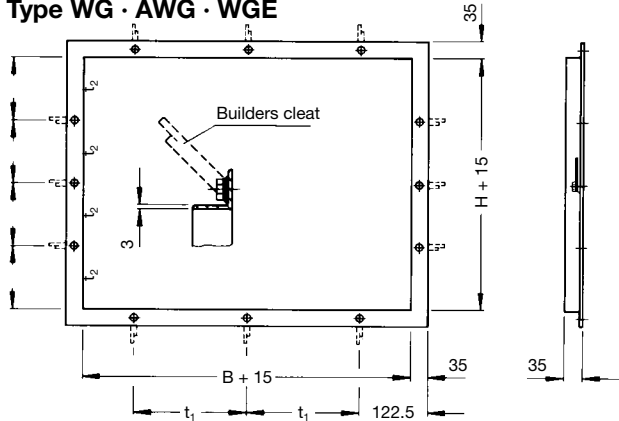

Interval  $t$  = flange hole pitch (page 7)

Materials:

Type WG · AWG: Galvanised steel

Type WGE: Stainless steel

### Type AWK

Sub-frames only for  $B \leq 1197$  mm and  $H \leq 497$  mm; special fixing straps are available for other dimensional combinations.

As delivered

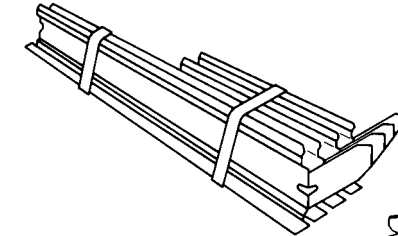

Assembly

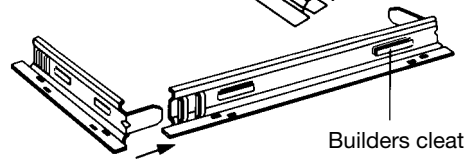

Material: Formed, galvanised sheet steel

## Installation Dimensions

### Type WG WGE

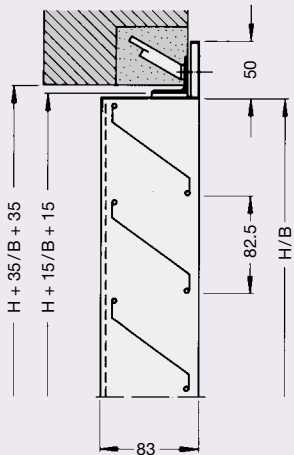

Opening size without masonry subframe  $B + 15/H + 15$

### Type AWG

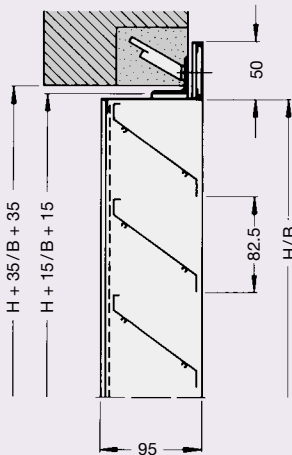

Opening size without masonry subframe  $B + 15/H + 15$

### Type AWK

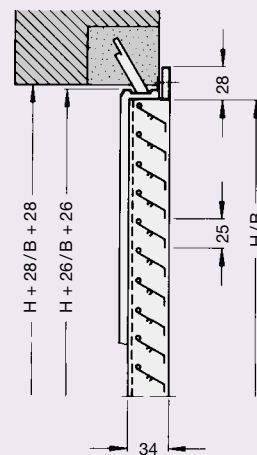

Opening size without masonry subframe  $B + 10/H + 10$

## Type WG-F

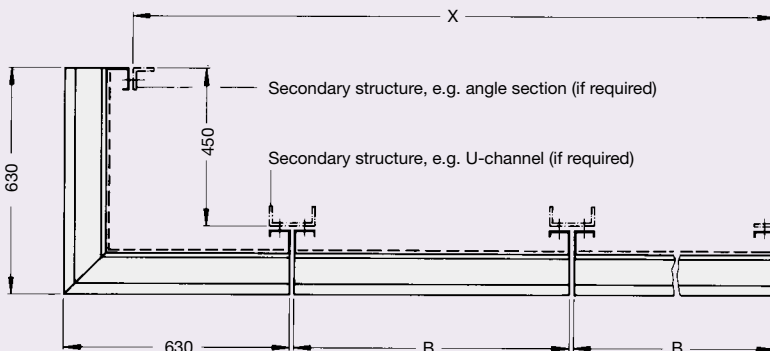

$$x = (n \times B) + 450$$

# Installation Details

## Type WG · AWG · WGE (split on B or H dimension)

If the B dimension is more than 1985 mm or the H dimension more than 1980 mm, then the louvre is sub-divided into two sections which can then be mounted either side by side or one on top of the other.

## Type AWG (linear construction)

Type AWG louvres are available in linear construction if the B dimension is more than 1985 mm. The width of the separating mullions is 2 x 20 mm.

Linear louvre construction for  $B > 1985-3985$  mm consists of two end sections.

Linear louvres construction for  $B > 3985$  mm consists of two end sections and any number of centre sections.

Masonry subframes may be used for installation if required.

### Type WG · AWG · WGE

Split on B dimension ( $B_1 = 2B + 100$ )

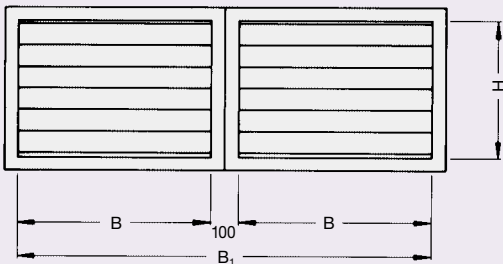

Split on H dimension ( $H_1 = 2H + 100$ )

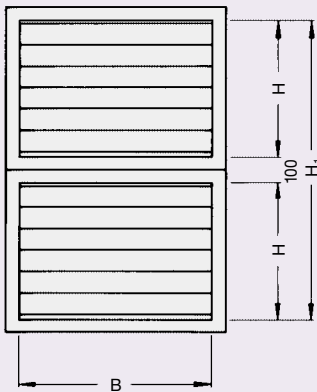

Special Masonry Subframe  
shown split on B dimension

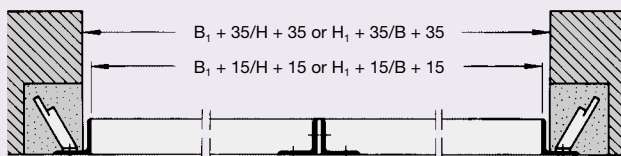

Opening size without masonry subframe  
 $B_1 + 15/H + 15$  or  $H_1 + 15/B + 15$

### Type AWG

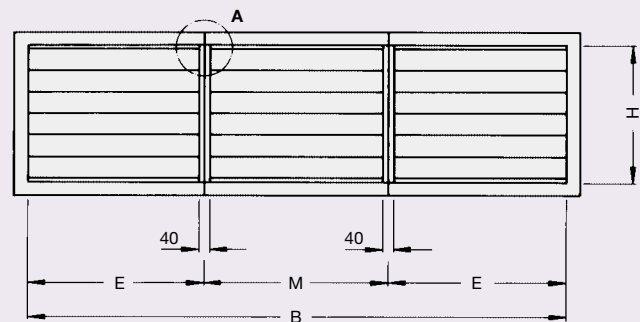

E = End section = 1092-1992 mm in increments of 100  
M = Centre section = 2000 mm

Detail A

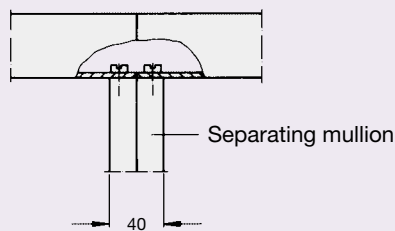

Special Masonry Subframe

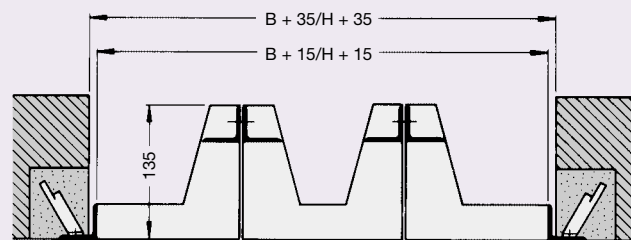

Opening size without masonry subframe  $B + 15/H + 15$

# Standard Sizes · Drilling Details

**Type WG · AWG · WGE**

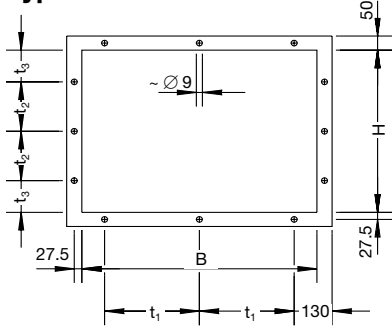

**Type AWG (linear construction)**

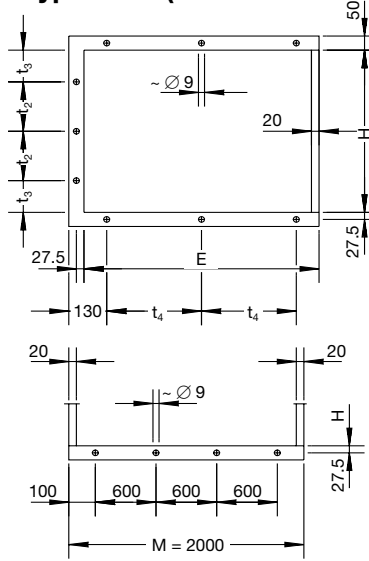

**Type AWK**

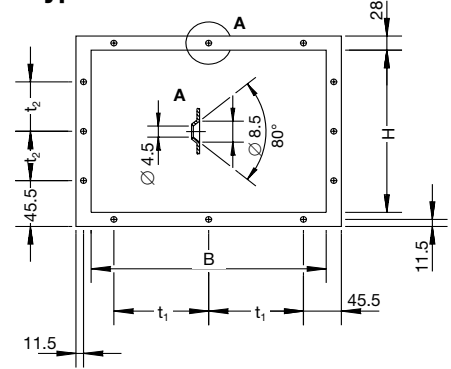

**Type WG · AWG · WGE**

B in mm	H in mm	Number of holes		≈ t <sub>1</sub> in mm	≈ t <sub>2</sub> in mm	≈ t <sub>3</sub> in mm
		per B-side	per H-side			
385	330	2	–	225	–	–
585	495	2	–	425	–	–
785	660	2	1	625	–	330
985	825	3	1	413	–	413
1185	990	3	1	513	–	495
1385	1155	3	1	613	–	578
1585	1320	4	2	475	445	437
1785	1485	4	2	542	500	492
1985	1650	4	2	608	555	547
	1815		2		610	602
	1980		3		499	491

**Type AWK**

B in mm		Number of holes per B-side	≈ t <sub>1</sub> in mm
97- 247	In increments of 50		
297- 397	In increments of 100	2	262-362
447- 497		3	206-231
597- 797		3	281-381
897-1297	In increments of 100	4	287-421
1397-1697		5	341-416
1797-1997		6	352-392

H in mm		Number of holes per H-side	≈ t <sub>2</sub> in mm
97- 497	In increments of 50		
597- 797	In increments of 100	3	281-381
897-1297		4	287-421
1397-1697		5	341-416
1797-1997		6	352-392

**Max. B or H dimension combinations that can be used**

B in mm	H in mm
1197	1997
1297	1597
1397	1497
1497	1397
1597	1297
1697	1197
1897	1097
1997	997

**Type WG-F**

B in mm	H in mm	Corner piece 90° in mm
1000	1000	600/600
1200	1125	
1400	1250	
1600	↓	
1800	2500	
2000		

**Type WG · AWG · WGE  
(Split on B or H dimensions)**

B <sub>1</sub> in mm	H in mm	H <sub>1</sub> in mm	B in mm
2070	330	2080	385
2470	495	2410	585
2870	660	2740	785
3270	825	3070	985
3670	990	3400	1185
4070	1155	3730	1385
	1320	4060	1585
	1485		1785
	1650		1985
	1815		
	1980		

Number of holes and pitch as finite louvre

**Type AWG  
(Linear construction)**

B in mm	H in mm	E in mm	Number of holes per E-side	≈ t <sub>4</sub> in mm
2185	330	1092	3	456
	495	1192	3	506
	660	1292	3	556
	825	1392	4	404
	990	1492	4	437
	1155	1592	4	471
	1320	1692	4	504
	1485	1792	4	537
	1650	1892	4	571
	1815	1992	4	604
	1980			

Number of holes and pitch on H dimension as type AWG

Types WG · AWG · WGE · WG-F: Any combination of dimensions B, B<sub>1</sub> and H, H<sub>1</sub> listed above can be supplied

# Product Range

Type		Construction	Wall frame	Surface	
				P1 Powder-coated	S2/S3 anodised
WG 2) WG 1 2) WG-BM WG 1-BM WG-HM WG 1-HM	Steel Construction	Basic construction	11	●	
		WG plus insect screen in galvanised steel	11	●	
		Basic construction, split on B dimension	12	●	
		WG-BM plus insect screen in galvanised steel	12	●	
		Basic construction, split on H dimension	13	●	
		WG-HM plus insect screen in galvanised steel	13	●	
AWG 2) AWG 1 2) AWG 2 2) AWG 3 2) AWG-BM AWG 1-BM AWG 2-BM AWG 3-BM AWG-HM AWG 1-HM AWG 2-HM AWG 3-HM AWG-B AWG 1-B AWG 2-B AWG 3-B	Aluminium Construction	Basic construction	11	●	●
		AWG plus insect screen in galvanised steel	11	●	●
		AWG but with wire mesh screen in stainless steel 1.4301	11	●	●
		AWG but with wire mesh screen and insect screen in stainless steel 1.4301	11	●	●
		Basic construction, split on B dimension	12	●	●
		AWG-BM plus insect screen in galvanised steel	12	●	●
		AWG-BM but with wire mesh screen in stainless steel 1.4301	12	●	●
		AWG-BM but with wire mesh screen and insect screen in stainless steel 1.4301	12	●	●
		Basic construction, split on H dimension	13	●	●
		AWG-HM plus insect screen in galvanised steel	13	●	●
		AWG-HM but with wire mesh screen in stainless steel 1.4301	13	●	●
		AWG-HM but with wire mesh screen and insect screen in stainless steel 1.4301	13	●	●
		Linear construction	14	●	●
		AWG-B plus insect mesh in galvanised steel	14	●	●
		AWG-B but with wire mesh screen in stainless steel 1.4301	14	●	●
	AWG-B but with wire mesh screen and insect screen in stainless steel 1.4301	14	●	●	
WGE WGE 1 WGE-BM WGE 1-BM WGE-HM WGE 1-HM	Stainless Steel Construction	Basic construction	15		
		WGE plus insect screen in stainless steel 1.4301	15		
		Basic construction, split on B dimension	16		
		WGE-BM plus insect screen in stainless steel 1.4301	16		
		Basic construction, split on H dimension	17		
		WGE-HM plus insect screen in stainless steel 1.4301	17		
AWK	Aluminium Construction	Basic construction	18 3)		E6-C-0
WG-F-E WG-F-T	Steel Construction	Basic construction, corner section		● 1)	
		Basic construction, centre section		● 1)	
WG-F-E-AL WG-F-E-AL 2 WG-F-T-AL WG-F-T-AL 2	Aluminium Construction	Basic construction, corner section		● 1)	●
		WG-F-E-AL but with wire mesh screen in stainless steel 1.4301		● 1)	●
		Basic construction, centre section		● 1)	●
		WG-F-T-AL but with wire mesh screen in stainless steel 1.4301		● 1)	●

1) Mullion only in RAL 9005

2) Louvre also for use in combination with multi-leaf and pressure relief dampers (see leaflet No. 3/4/EN/..)

Finish on request:

P1 = Powder coated to RAL colour (coating thickness approx. 60-80 µm)  
Price on request

S2/S3 = anodised to Euras-standard (coating thickness approx. 20 µm)  
Finish: surface etched (E6)

Colours: C- 0 = Natural  
C-31 = Pale bronze  
C-32 = Light bronze  
C-33 = Medium bronze  
C-34 = Dark bronze  
C-35 = Black  
S2 = e.g. E6-C-33  
S3 = E6-C-0

3) Subframes only for B ≤ 1197 mm and H ≤ 497 mm; special fixing straps are available for other dimensional combinations.

# Technical Data

## Nomenclature

- $v$  in m/s: Air velocity based on cross section A  
 $A$  in m<sup>2</sup>: Flow cross section:  
 WG · WGE · AWG:  $B \times (H - 0.085 \text{ m})$   
 AWK:  $B \times (H - 0.028 \text{ m})$   
 WG-F:  $B \times (H - 0.125 \text{ m})$   
 (use  $W$  and  $H$  dimensions in m)
- $\Delta p_t$  in Pa: Total pressure drop  
 $L_W = L_{W0} + K$  in dB/Oct.: Octave sound power level related to A  
 $L_{W0}$  in dB/Oct.: As before, but related to  $A = 1.0 \text{ m}^2$   
 $L_{WA} = L_{WAO} + K$  in dB(A): A-weighted sound power level related to A  
 $L_{WAO}$  in dB(A): As before, but related to  $A = 1.0 \text{ m}^2$   
 $L_{WNC} = L_{WNC0} + K$  : NC rating of sound power level related to A  
 $L_{WNC0}$  : As before, but related to  $A = 1.0 \text{ m}^2$   
 $K$  : Sound power level correction for octave, dB(A) or NC values at flow cross section greater than or smaller than  $1.0 \text{ m}^2$   
 $f$  in Hz: Octave band centre frequency

## Example

Data given: Louvre type WG, installation type B  
 $B = 585 \text{ mm}$ ,  $H = 495 \text{ mm}$ ,  $A \approx 0.24 \text{ m}^2$   
 $v = 3 \text{ m/s}$

- Required: – Total pressure drop  $\Delta p_t$   
 – A-weighted sound power level  $L_{WA}$   
 – Octave band sound power level of regenerated noise  $L_W$   
 – NC rating of sound power spectrum  $L_{WNC}$

## Result:

$\Delta p_t \approx 50 \text{ Pa}$  (from diagram)  
 $L_{WA} = 55 - 6 = 49 \text{ dB(A)}$

$f$ in Hz	63	125	250	500	1000	2000	4000	8000
$L_W$ in dB/Oct.	44	46	48	48	48	41	34	24

$L_{WNC} \approx 52 - 6 = 46$

## Type WG · WGE · AWG · AWK

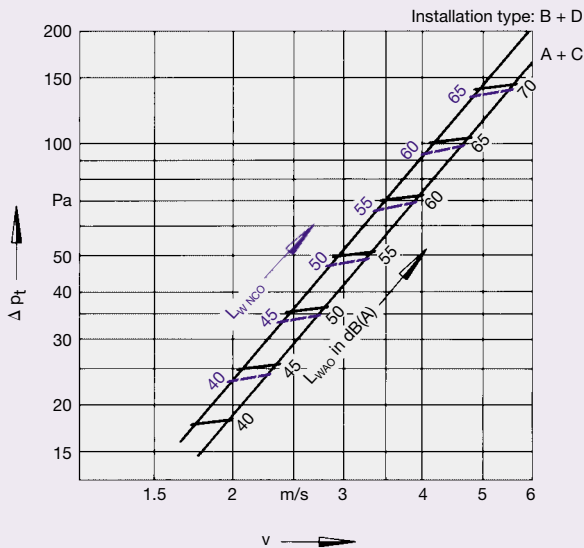

## Type WG-F

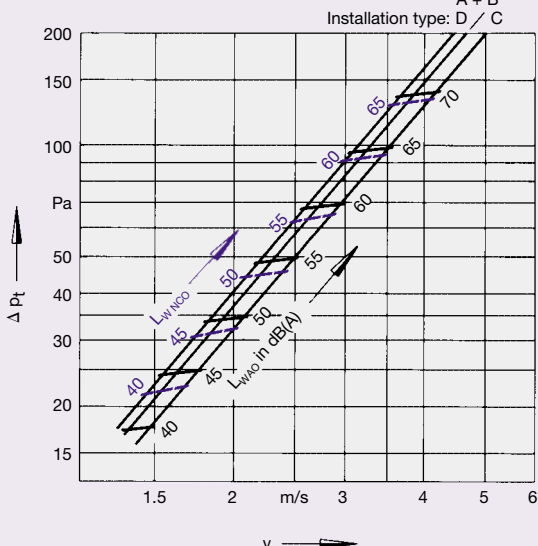

## Sound Power Level Spectra

Type	Installations-type	$v$ in m/s	WG · WGE AWG · AWK								WG-F								
			Sound power level ( $L_{W0}$ in dB/Oct., $N_0 = 10^{-12} \text{ W}$ )																
			$f = 63$		125		250		500		1000		2000		4000		8000		
A	1	1	26	23	22	19	11	–	–	–	–	–	–	–	–	–	–	–	–
		2	45	44	42	40	37	30	18	12	52	48	45	48	46	37	25	13	–
		3	54	55	54	51	50	43	35	20	63	62	57	57	59	54	44	31	–
		4	59	63	62	60	58	56	48	36	70	70	66	63	66	64	56	43	–
		5	63	72	73	72	69	68	61	53	75	81	80	75	75	77	72	62	–
		6	63	72	73	72	69	68	61	53	75	81	80	75	75	77	72	62	–
B	1	1	26	23	22	19	11	–	–	–	–	–	–	–	–	–	–	–	
		2	41	43	44	44	39	31	22	10	51	48	45	48	46	37	25	13	–
		3	50	52	54	54	54	47	40	30	63	62	57	57	59	54	44	31	–
		4	55	59	62	62	62	57	49	40	70	70	66	63	66	64	56	43	–
		5	63	68	70	72	72	72	65	60	75	81	80	75	75	77	72	62	–
		6	63	68	70	72	72	72	65	60	75	81	80	75	75	77	72	62	–
C	1	1	26	23	22	19	11	–	–	–	–	–	–	–	–	–	–	–	
		2	45	44	41	40	37	29	18	11	50	46	43	46	44	35	23	11	–
		3	54	55	54	51	50	43	35	20	60	59	54	54	56	52	41	28	–
		4	59	63	62	60	58	56	48	36	67	68	64	61	64	62	53	41	–
		5	63	72	73	72	69	68	61	53	73	79	77	73	72	75	69	60	–
		6	63	72	73	72	69	68	61	53	73	79	77	73	72	75	69	60	–
D	1	1	26	23	22	19	11	–	–	–	–	–	–	–	–	–	–	–	
		2	41	43	44	44	39	31	22	10	50	53	53	53	49	41	31	19	–
		3	50	52	54	54	54	47	40	30	59	62	63	64	63	57	49	37	–
		4	55	59	62	62	62	57	49	40	65	68	70	71	71	67	59	49	–
		5	63	68	70	72	72	72	65	60	72	77	80	81	82	81	75	67	–
		6	63	68	70	72	72	72	65	60	72	77	80	81	82	81	75	67	–

## Sound Power Level Correction Values

A in m <sup>2</sup>	0.10	0.12	0.25	0.30	0.40	0.50	0.60	1.00	1.25	1.60	2.00	3.00	4.00
K	-10	-9	-6	-5	-4	-3	-2	0	+1	+2	+3	+5	+6

## Installation Types

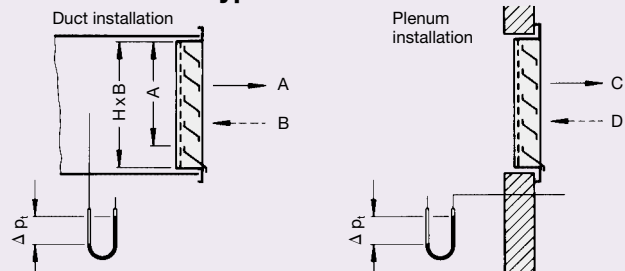

All technical details refer to the basic design.

# Order Details

## Order Codes

These codes do not need to be completed for standard products

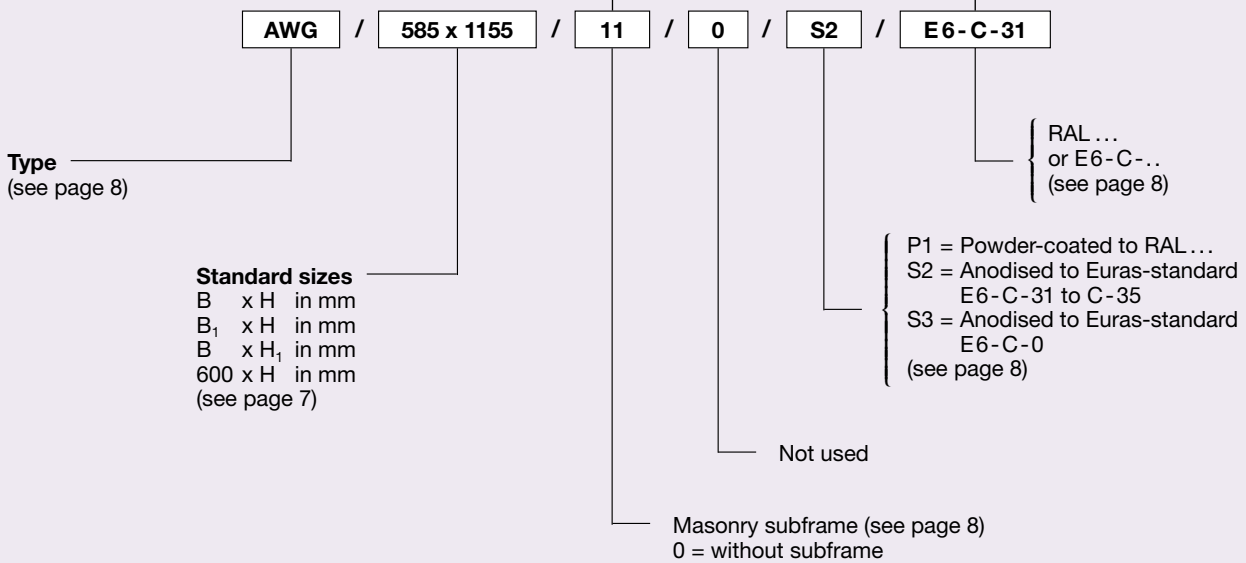

## Specification Text

Weather resistant louvres for protection against direct ingress of rain, leaves and birds into the intake and discharge openings of air conditioning systems; essentially comprising border frame with inset, rain resistant blade sections and wire mesh screen on rear.

Constructions and materials:  
 See pages 3 and 4

Masonry subframe and construction variations, e.g. linear construction anodised finish:  
 See page 8

Make: TROX

Type: See page 8

## Order Example

Make: TROX  
 Type: AWG / 585 x 1155 / 11 / 0 / S2 / E6-C-31  
 Qty: 4