

Volume Flowrate Measuring Unit

Type VMR



TROX[®] TECHNIK

Description · Technical Data

Application

Trox volume flow rate measuring unit Type VMR is used for manual determination of volume flow rate or for continuous monitoring of the actual flow rate in ventilation ducts. Because of its low pressure drop it is suitable for permanent installation in ventilation system and is easily installed and dismantled.

Description

The measuring unit consists of a circular casing and a differential pressure grid which provides the mean value for determining the volume flow rate. If required, pressure transducers can be factory fitted, wired and tubed.

In systems with contaminated air and/or aggressive particles static pressure sensors should be used (diaphragm measurement principle).

Construction

Casing

- Circular construction
- Suitable for ducts to DIN 24 145 or DIN 24 146
- Same connection diameter on both ends with groove for lip seal (lip seal can be fitted at the factory or on site by others)
- With optional flange to DIN 24 154, Part 1 or with spun edge for use with duct clamping system (by others)
- Connection nipple for tube with $d_i = 6 \text{ mm}$

Volume Flow Rate Measurement

- Manometer (by others), or by optional pressure transducer
- For supply and extract air
- Measurement accuracy $\pm 5 \%$ even with unfavourable supply and extract ducting arrangement
- Measured pressure differential from 5 to approx. 250 Pa
- Pressure drop 10 to 26 % of measured pressure differential



Installation Conditions

Minimum straight duct length for supply and extract conditions

- | | |
|--|----|
| 1) Bend connection | 1D |
| Angle of sensor tubes must be at 45° to the bend centreline | |
| 2) Connection to main duct branch | 5D |
| 3) Reducing duct transformation | 2D |

Nomenclature

- | | | |
|--------------|-----------------------------------|--------------------------------|
| \dot{V} | in l/s or m^3/h : | Volume flow rate |
| Δp_w | in Pa: | Measured pressure differential |
| ρ | in kg/m^3 : | Air density |
| Δp_g | in Pa: | Total pressure drop |
| ΔV | in $\pm \%$: | Accuracy of measurement |

Table 1: Technical Data

Size	$\dot{V}^3)$		C-value ¹⁾	ΔV in $\pm \%$	$\Delta p_g^2)$ in $\%$
	in l/s	in m^3/h			
100	10- 95	36- 342	6.1	5	26
125	15- 150	54- 540	9.7	5	24
160	25- 250	90- 900	15.9	5	22
200	40- 405	144- 1458	25.5	5	19
250	60- 615	216- 2214	39.0	5	17
315	105- 1025	378- 3690	65.0	5	15
400	170- 1680	612- 6048	106.0	5	10

Highlighted values are nominal volume flow rates

- 1) At $\rho = 1.2 \text{ kg}/\text{m}^3$ related to l/s
- 2) Of Δp_w
- 3) Typical values

Volume flowrate measurement

The volume flowrate is calculated using the formulae:
with $\rho = 1.2 \text{ kg/m}^3$:

$$\dot{V} = C \cdot \sqrt{\Delta p_w} \quad \text{in l/s} \quad \dot{V} = C \cdot \sqrt{\Delta p_w} \cdot 3.6 \quad \text{in m}^3/\text{h}$$

for $\rho \neq 1.2 \text{ kg/m}^3$:

$$\dot{V} = C \cdot \sqrt{\Delta p_w} \cdot \sqrt{\frac{1.2}{\rho}} \quad \text{in l/s or m}^3/\text{h}$$

Table 2: Dimensions in mm

Size	$\varnothing D_a$	$\varnothing D_1$	$\varnothing D_2$	b	s	$\varnothing d$	n ¹⁾
100	99	111	132	25	3	9.5	4
125	124	136	157	25	3	9.5	4
160	159	171	192	25	4	9.5	6
200	199	211	233	25	4	9.5	6
250	249	261	283	25	4	9.5	6
315	314	326	352	30	4	9.5	8
400	399	411	438	30	4	9.5	8

1) n = Number of flange holes

Example

Given:

Size 160
C-value = 15.9 (from Table 1)
 $\Delta p_w = 100 \text{ Pa}$
(read by manometer)

Required:

Volume flowrate \dot{V} in l/s or m³/h
at $\rho = 1.2 \text{ kg/m}^3$

Calculation:

$$\dot{V} = 15.9 \cdot \sqrt{100}$$

Result:

159 l/s or 572 m³/h

Table 3: Weight in kg

Size	VMR, VMR-BK	VMR-FL
100	0.8	1.2
125	1.0	1.5
160	1.2	2.1
200	1.6	2.7
250	1.9	3.3
315	2.4	4.5
400	3.1	5.7

Standard construction

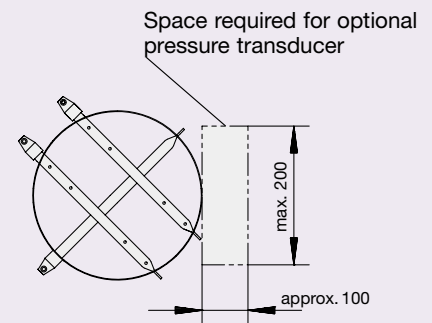
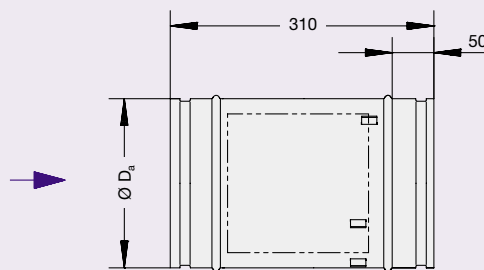

With Flange

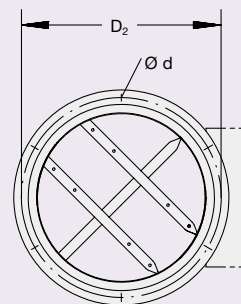
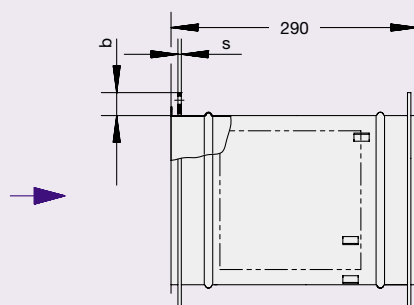

With spun edge

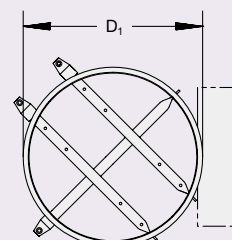
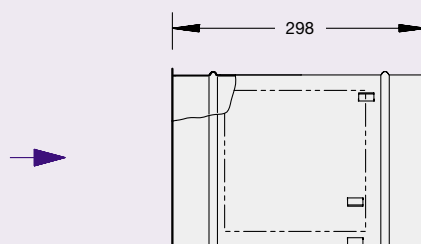

Order Details

Specification Text

Volume flowrate measuring unit for manual determination of volume flowrate or for continuous monitoring of the actual flowrate in ventilation ducts. Consists of circular housing with averaging differential pressure sensor grid and factory fitted, pre-wired static pressure transducer as an option. Same connection diameter on both ends with groove for lip seal, to fit ducts DIN 24 145 or DIN 24 146. Measurement accuracy $\pm 5\%$ even with unfavourable supply and extract ducting arrangements. Pressure drop 10 to 26 % of measured pressure differential, depending on size.

Materials:

Galvanised steel casing and attachments.
Aluminium sensor tubes.

Order code

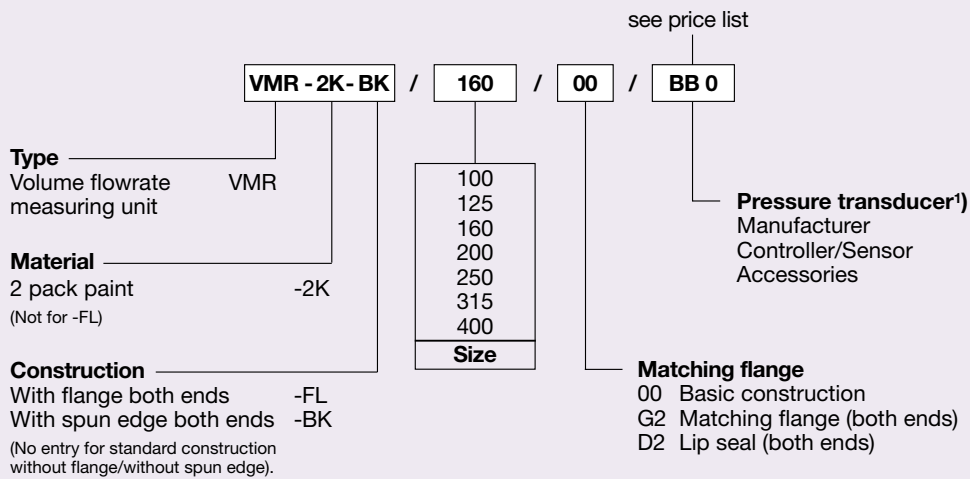

1) No entry, measuring unit without pressure transducer

Order Example

Manufacturer: TROX
Type: VMR - 2K - BK / 160 / 00 / BB 0