

VARYCONTROL VAV Terminal Boxes

for variable volume systems

Type TVZ · TVA

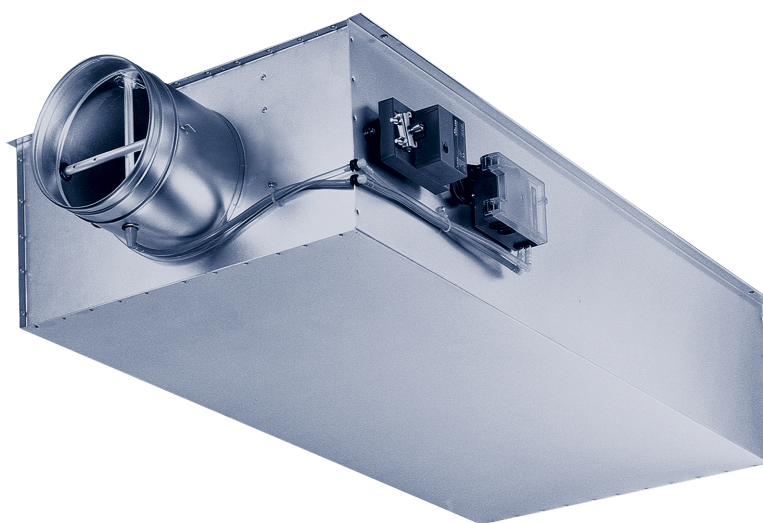

TROX[®] TECHNİK

Trox (U.K.) Ltd
Caxton Way
GB-Thetford
Norfolk IP24 3SQ

Telephone +44 (0)1842 754545
Telefax +44 (0)1842 763051
www.troxuk.co.uk
e-mail: trox@troxuk.co.uk

Contents · Description

Description	2	TVZ Case-Radiated Noise	12
Construction and Dimensions	3	TVZD Case-Radiated Noise	13
Air Volume Control	5	TVZ Air-Regenerated Noise in	
Entry Flow Conditions	5	the High Pressure Duct	14
Nomenclature	6	TVA Air-Regenerated Noise in	
Volume Flow Range	6	the High Pressure Duct	15
TVZ Air-Regenerated Noise, without TS	8	TVA Air-Regenerated Noise, without TS	16
Diagrammatic Layout of the Test Laboratory	8	TVA Air-Regenerated Noise, with TS	17
TVZ Air-Regenerated Noise, with TS	9	TVA Case-Radiated Noise	18
Acoustic Insertion Loss	9	TVAD Case-Radiated Noise	19
TVZ Air-Regenerated Noise with Reheat Coil,		Reheat Coil Selection	20
without TS	10	TVZ and TS Order Details	21
TVZ Air-Regenerated Noise with Reheat Coil,		TVA and TS Order Details	22
with TS	11		

TVZ VAV Terminal Box



Trox VARYCONTROL VAV controllers Type TVZ · TVA provide volume flow control for variable air volume systems for supply air or extract air. The box consists of a casing with circular high pressure and rectangular low pressure duct connections, integral acoustic silencer, averaging differential pressure grid for volume flow measurement. The damper blade has a plastic elastomer seal giving a closed leakage complying with DIN 1946, Part 4. To reduce radiated noise the box can be supplied with acoustic lagging. A discharge secondary silencer type TS is available and boxes can be supplied with one row, two row or 4 row reheat coils.

TVZD VAV Terminal Box



The control components (velocity controller, transducer, actuator) are factory assembled and wired and the tubing connected. Trox VAV boxes are available with most makes of control components, which are selected to suit the control specification.

Every VAV box is factory tested and set to the required volume flows.

Further information on application, selection and the control components available, is contained in the Product Information leaflet "Varycontrol VAV Units".

Construction · Dimensions

Design Features

Casing

- Circular spigot connection on high pressure side complying with DIN 24 145 and DIN 24 146 with groove for lip seal (lip seal can be fitted at the factory or on site by others)
- Low pressure side suitable for slide-on flange or angle flange connection
- Holes in the edge of the casing for support rods
- Casing air leakage rate complies with class II, VDI 3803 and DIN V 24 194, Part 2
- Conforms with clean room class 3, VDI 2083, and class 100, US standard 209b

Volume Flow Control

- Either pneumatic or electronic
- Suitable for supply or extract air
- Volume control range up to 10:1, depending on the type of controller

- Set volume controlled with high level of accuracy, even under adverse upstream conditions, by means of averaging differential pressure sensor (see page 5)
- Differential pressure range 20 to 1500 Pa
- Full shut off using the control damper wiring once installed
- Control damper leakage complies with DIN 1946, Part 4
- Horizontal or vertical mounting (when using diaphragm pressure sensors, mount according to the labels on the box)
- Volume flow set and airflow tests conducted on each box at the factory
- Volume flow can be measured and adjusted on the box at site
- The mechanical components are maintenance free
- Operating temperature range 10 to 50 °C

TVZ · TVA

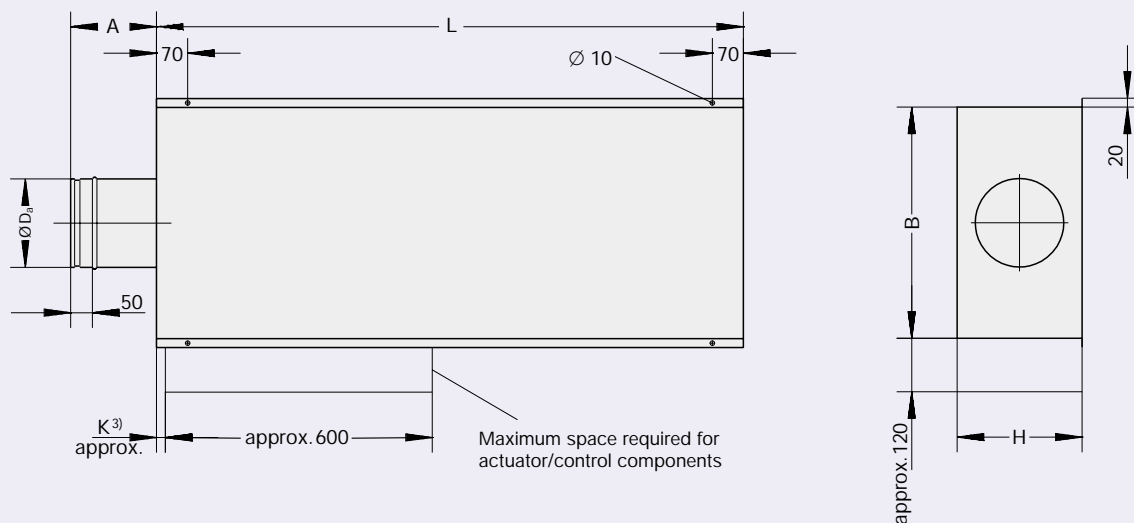

TVZD · TVAD

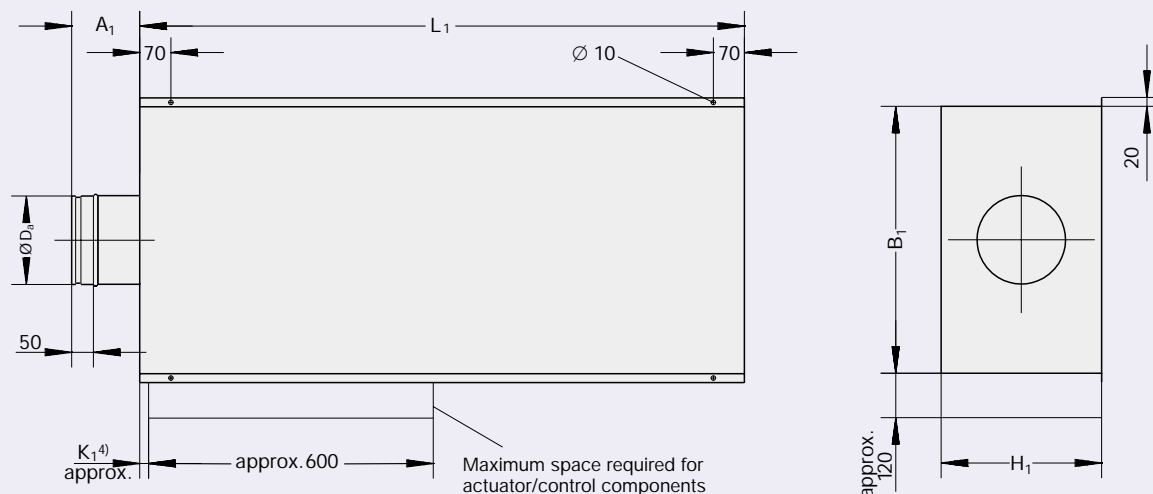

Ensure adequate access is provided to control components

Control components are situated on the right hand side when seen from the direction of the airflow (with the folded seam uppermost)

Additional Acoustic Cladding

- Reduces the radiated noise from the casing
- Outer casing made of galvanised sheet steel
- Sound absorbent lining
- Rubber isolators for insulation of structure borne noise

Reheat Coil

- For terminal reheat of primary air volume
- Casing made of galvanised sheet steel
- Flanged on both ends
- Copper tubes and aluminium fins
- One or two row (four-row formed by combination)
- Available factory-fitted or supplied separately
- Maximum operating pressure 16 bar
- Water connections horizontal, air venting by customer

TS Secondary Silencer

- For reduction of duct-borne noise
- Casing made of galvanised sheet steel
- Mineral wool lining
- With angle flange or slide-on duct flanges

Materials

- Casing made of galvanised sheet steel
- Lining in the attenuator section and in the control damper chamber with material fire rating A2, DIN 4102
- Mineral wool with glass fibre facing in the attenuator section suitable for air velocities up to 20 m/s
- Control damper made of galvanised sheet steel with thermoplastic elastomer seal
- Sensor tubes in aluminium
- Plastic plain bearings

TS Secondary Silencer

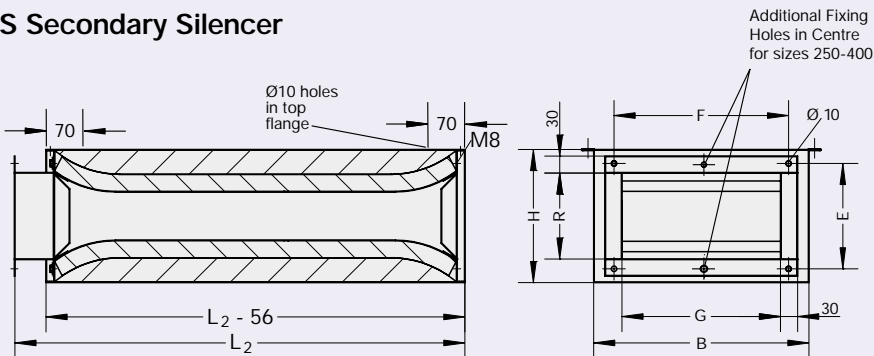

TS or duct connection

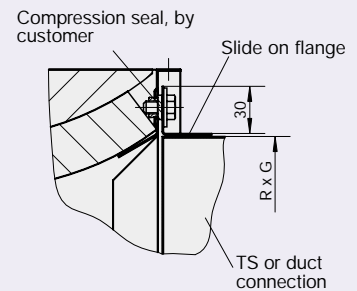

Rectangular duct connection

Additional Fixing Holes in Centre for sizes 250-400

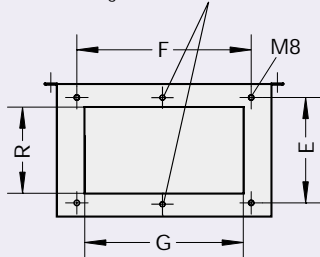

Reheat Coil²⁾

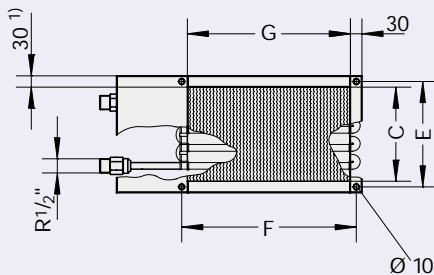

Reheat coil connection

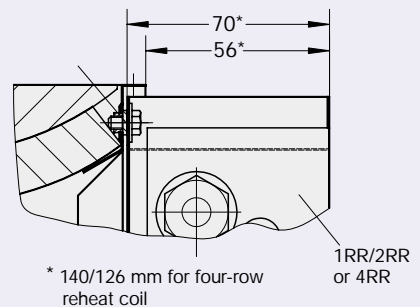

Table 1: Dimensions in mm

Size	Duct connections					Casing													
	øD _s	E	F	R	G	A		A ₁		B	B ₁	C	H	H ₁	K	K ₁	L	L ₁	L ₂
						TVZ	TVA	TVZD	TVAD										
125	124	186	232	152	198	150	185	110	145	300	380	152	236	316	0	40	1035	1075	806
160	159	186	342	152	308	200	170	160	130	410	490	152	236	316	10	50	1035	1075	806
200	199	244	492	210	458	200	140	160	100	560	640	203	281	361	20	60	1320	1360	956
250	249	235	632	201	598	250	100	210	60	700	780	203	311	391	35	75	1440	1480	956
315	314	286	832	252	798	250	250	210	210	900	980	254	361	441	40	80	1440	1480	1056
400	399	388	932	354	898	250	180	210	140	1000	1080	356	446	526	60	100	1820	1860	1306

1) 25 for size 400
 2) Duct connection dimensions R x G
 3) With pneumatic controls K - 20 (Projection for sizes 125 to 160)
 4) With pneumatic controls K₁ - 20

Table 2: Weight in kg

Size	TVZ TVA	TVZD TVAD	TS	Reheat coil (2 RR)
125	21	41	10	2.4
160	25	50	15	3.3
200	33	63	22	4.8
250	55	95	37	6.0
315	73	133	42	8.7
400	118	193	50	12.7

Air Volume Control · Entry Flow Conditions

Air Volume Control shown by the Example of a Supply Box with Combined Extract Box

The room temperature controller signals the velocity controller on the supply box and adjusts its set point between the minimum and maximum volume values set at the factory, as a function of the room temperature. The differential pressure Δp_w measured at the differential pressure grid is transmitted via the supply air transducer to the velocity controller. This signal is compared with the set point value. If there is any variance, the control damper is adjusted accordingly by the actuator, so that the air volume is held constant within a small tolerance over the entire static differential pressure range. To control the extract air volume, the output signal from the supply air transducer is connected to the extract air velocity controller. This ensures that the extract air volume follows changes in the supply air volume. Ratio or differential extract volume control can be used, depending on the type of controller used.

- ① Differential pressure grid
 - ② Control damper
 - ③ Supplying air transducer
 - ④ Extract air transducer
 - ⑤ Actuator
 - ⑥ Room temperature controller (by customer)
 - ⑦ Supply velocity controller
 - ⑧ Extract velocity controller
- Site wiring by customer

Volume control

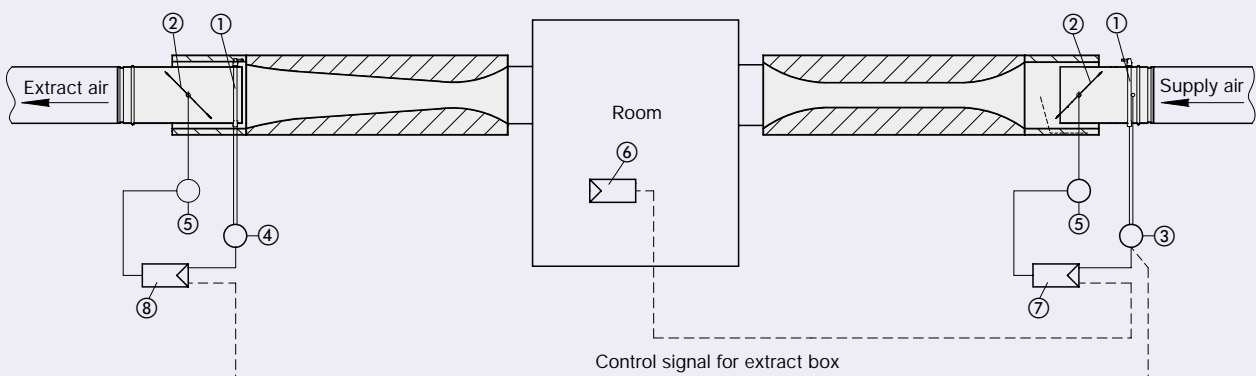

Entry flow conditions

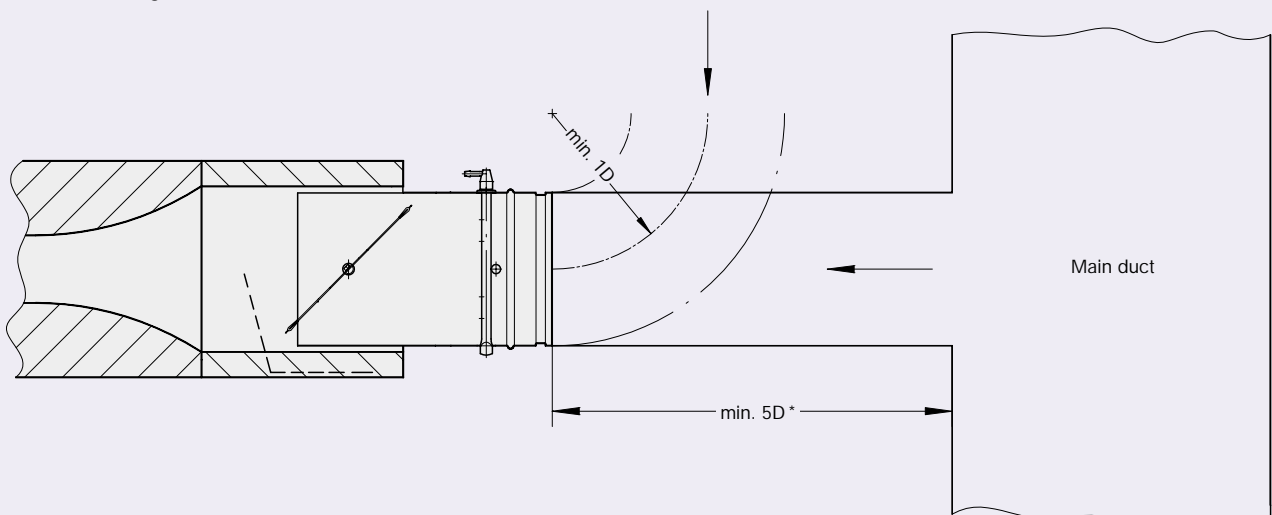

* with smaller length, the tolerances increase

Nomenclature · Volume Flow Range

Nomenclature

f_m in Hz: Octave centre frequency
 L_W in dB: Sound power level (re 1pW) of air-regenerated noise in connection duct
 L_{W1} in dB: Sound power level (re 1pW) of case-radiated noise
 L_{WR} in dB: Sound power level (re 1pW) of air-regenerated noise in round duct
 L_{WR} in dB(A): A-weighted sound power level (re 1pW) of air-regenerated noise in round duct
 L in dB(A): A-weighted sound power level (re 20 μ Pa) of air-regenerated noise, assuming reflection attenuation and 8 dB/Oct. room attenuation
 L_1 in dB(A): A-weighted sound power level (re 20 μ Pa) of case-radiated noise, assuming 8 dB/Oct. room attenuation
 NC : Noise criteria of sound pressure spectrum, assuming 8 dB/Oct. room attenuation
 NC_R : Noise criteria of sound pressure spectrum in round duct
 D_e in dB: Insertion loss
 Δp_{st} in Pa: Static pressure differential

$\Delta p_{st\ min}$ in Pa: Minimum static pressure differential
 \dot{V} in l/s or m³/h: Volume flow
 $\Delta \dot{V}$ in \pm %: Volume flow tolerance from set point
 ΔL in dB or NC: Level correction values for TVZ with air heater
 RR : Number of rows
 K : Number of circuits (distributors)
 \dot{m}_w in kg/s: Mass flow (water)
 \dot{m}_{wK} in kg/s: Mass flow per circuit
 \dot{Q} in kW: Heat output
 t_e in °C: Inlet air temperature
 t_a in °C: Discharge air temperature
 t_{wm} in °C: Mean water temperature
 v in m/s: Air velocity in rectangular duct
 Δp_v in kPa: Water pressure drop
 Δt in K: Air temperature differential
 Δt_w in K: Water temperature differential

All noise levels determined in reverberant room. Sound power levels determined and corrected in accordance with ISO 5135, December 1997.

Table 3: Volume flow ranges and minimum pressure differential

Size	\dot{V} in l/s in m ³ /h		$\Delta p_{st\ min}$ in Pa					TVA	TS*
			TVZ	TVZ with reheat coil					
				1RR	2RR	4RR			
125	15	54	20	20	20	25	20	–	
	60	216	20	30	40	60	25	5	
	105	378	45	80	110	170	80	20	
	150	540	90	140	190	290	150	40	
160	25	90	20	20	20	25	20	–	
	80	288	20	30	40	60	25	5	
	145	522	25	55	80	130	50	10	
	250	900	80	140	200	320	150	20	
200	40	144	20	20	20	25	20	–	
	180	648	20	30	40	60	30	5	
	310	1116	40	70	100	150	95	10	
	405	1458	80	130	180	280	190	20	
250	60	216	20	20	20	25	20	–	
	270	972	20	35	45	70	25	5	
	470	1692	40	80	110	180	75	10	
	615	2214	80	145	210	340	150	20	
315	105	378	20	20	20	25	20	5	
	425	1530	20	35	45	70	30	10	
	740	2664	40	75	110	170	90	20	
	1025	3690	80	140	195	310	180	40	
400	170	612	20	20	20	25	20	5	
	715	2574	20	35	50	80	25	10	
	1250	4500	40	80	120	190	75	20	
	1680	6048	80	150	210	340	150	40	

*) Additional pressure differential to be taken into account

Table 4: Volume flow range for construction with diaphragm pressure transducer

Size	$\dot{V}^{1)}$		$\Delta \dot{V}^{1)}$ in $\pm\%$
	in l/s	in m ³ /h	
125	30	108	9
	60	216	7
	105	378	6
	150	540	5
160	50	180	9
	80	288	8
	145	522	7
	250	900	5
200	80	288	9
	180	648	7
	310	1116	5
	405	1458	5
250	120	432	9
	270	972	7
	470	1692	5
	615	2214	5
315	210	756	9
	425	1530	7
	740	2664	6
	1025	3690	5
400	340	1224	9
	715	2574	7
	1250	4500	6
	1680	6048	5

Table 5: Volume flow range for construction with dynamic pressure transducer

Size	$\dot{V}^{1)}$		$\Delta \dot{V}^{1)}$ in $\pm\%$
	in l/s	in m ³ /h	
125	15	54	20
	60	216	7
	105	378	6
	150	540	5
160	25	90	20
	80	288	8
	145	522	7
	250	900	5
200	40	144	20
	180	648	7
	310	1116	5
	405	1458	5
250	60	216	20
	270	972	7
	470	1692	5
	615	2214	5
315	105	378	20
	425	1530	7
	740	2664	6
	1025	3690	5
400	170	612	20
	715	2574	7
	1250	4500	6
	1680	6048	5

1) Typical values

TVZ Air-Regenerated Noise without TS

Schematic Layout of the Test Laboratory

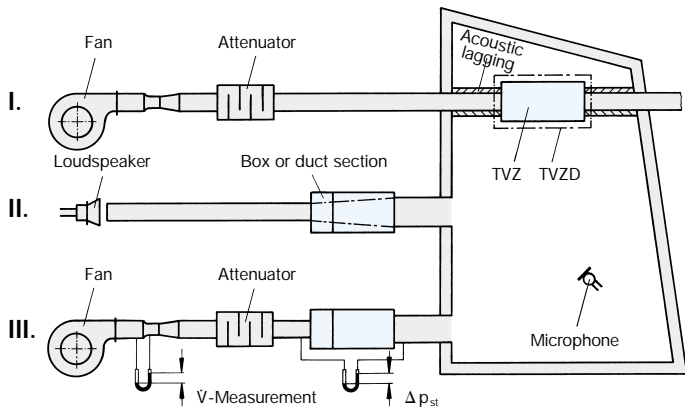

- I. Determination of the case-radiated sound power level
- II. Determination of the insertion loss difference in the sound level measured when substituting straight piece of duct for box
- III. Determination of the duct-transmitted air-regenerated sound power level

Table 6

Size	V		$\Delta p_{st} = 200 \text{ Pa}$														$\Delta p_{st} = 500 \text{ Pa}$														$\Delta p_{st} = 1000 \text{ Pa}$													
			L _w in dB														L _w in dB														L _w in dB													
			f _m in Hz														f _m in Hz														f _m in Hz													
			63	125	250	500	1000	2000	4000	8000	L in dB(A)	NC	63	125	250	500	1000	2000	4000	8000	L in dB(A)	NC	63	125	250	500	1000	2000	4000	8000	L in dB(A)	NC												
l/s	m ³ /h	63	125	250	500	1000	2000	4000	8000	L in dB(A)	NC	63	125	250	500	1000	2000	4000	8000	L in dB(A)	NC	63	125	250	500	1000	2000	4000	8000	L in dB(A)	NC													
125	15	54	55	32	25	16	<	<	<	19	<	15	56	31	25	16	<	<	<	22	15	18	60	37	33	20	<	<	19	26	20	22												
	35	126	57	43	35	18	<	<	<	21	17	17	60	41	36	23	<	<	<	23	19	19	63	42	39	26	15	<	21	30	24	26												
	60	216	51	47	37	22	<	<	<	22	19	18	53	46	41	26	<	<	15	22	22	18	59	47	43	30	18	17	23	31	26	27												
	95	342	57	51	43	28	19	<	<	19	24	16	58	58	47	32	20	<	18	28	29	24	62	55	48	35	24	19	26	36	31	31												
	150	540	59	54	51	42	37	33	19	20	34	27	62	60	55	38	28	20	18	29	35	30	66	61	53	40	32	25	27	37	35	32												
160	25	90	53	45	29	17	<	<	<	19	16	15	55	37	29	20	<	<	<	19	15	15	59	40	35	23	<	<	16	23	20	19												
	65	234	52	48	40	23	<	<	<	20	22	16	54	49	41	28	16	<	<	23	24	19	58	50	43	30	18	17	20	30	27	26												
	100	360	55	53	41	25	15	<	19	21	24	17	56	54	45	34	26	23	21	23	29	20	60	56	47	36	27	24	25	31	31	27												
	170	612	58	56	52	33	25	17	17	20	33	28	60	60	52	37	28	20	18	27	34	28	64	62	53	40	30	25	25	34	36	30												
	250	900	65	61	53	40	35	29	21	22	36	29	66	66	56	44	38	33	25	31	39	33	69	67	58	46	39	34	30	37	41	35												
200	40	144	51	32	26	15	<	<	15	20	15	16	42	33	29	19	16	<	<	23	17	19	54	37	33	23	18	<	20	27	22	23												
	110	393	47	41	34	20	<	<	<	18	<	<	55	44	37	28	<	<	22	22	18	58	46	39	31	18	<	16	31	26	27													
	180	648	50	45	36	21	<	<	<	20	<	20	58	49	41	30	15	<	<	25	26	21	61	50	44	34	22	16	19	33	30	29												
	280	1008	55	48	40	31	23	17	<	19	25	16	58	53	47	34	25	18	<	28	31	24	64	56	46	39	28	22	22	35	34	31												
	405	1458	64	56	49	40	35	30	24	22	35	27	64	57	50	44	39	34	27	31	37	30	68	60	54	46	39	35	30	38	40	33												
250	60	216	42	36	25	15	<	<	<	18	<	<	46	40	28	15	<	<	<	20	16	16	55	41	35	23	19	<	<	26	22	22												
	170	612	48	39	30	18	<	<	<	16	<	<	49	44	37	26	<	<	<	18	21	<	55	47	40	29	20	17	17	24	25	20												
	280	1008	50	45	33	22	15	<	<	18	20	<	55	50	41	29	22	20	21	26	27	22	58	53	45	33	26	23	24	29	30	25												
	470	1692	56	50	41	36	31	27	24	28	30	24	59	57	46	37	32	28	27	31	33	27	65	61	52	41	36	32	31	35	38	31												
	615	2214	63	56	48	43	39	36	34	36	38	31	66	60	52	46	42	39	36	39	41	34	69	64	57	49	45	42	39	42	44	37												
315	105	378	41	37	31	15	<	<	<	16	<	<	49	38	35	23	17	<	<	22	21	18	55	40	38	25	21	<	18	29	25	25												
	265	954	53	47	40	22	<	<	<	25	25	21	52	51	45	27	25	22	27	34	31	30	60	51	46	31	28	25	27	37	33	32												
	420	1512	53	49	41	22	<	<	15	29	27	25	61	58	49	33	31	29	30	37	36	32	63	57	51	37	34	31	32	40	38	35												
	720	2592	60	52	43	30	26	20	27	37	32	32	65	60	51	39	37	35	35	42	39	37	68	64	56	43	40	36	38	44	43	39												
	1025	3690	67	58	53	41	37	34	34	38	39	33	72	65	54	47	45	42	41	45	45	40	73	68	60	50	46	43	45	48	48	43												
400	170	612	41	38	32	<	<	<	<	17	<	<	41	43	37	24	16	<	20	25	23	21	51	46	41	27	21	<	27	33	29	29												
	445	1602	51	48	37	21	18	18	20	24	25	20	55	53	49	29	26	26	31	35	34	31	56	54	50	35	32	30	38	44	39	39												
	710	2556	54	51	39	27	24	23	26	30	29	26	58	56	50	34	31	30	34	38	36	33	61	59	53	38	35	34	41	46	41	41												
	1250	4500	67	56	47	39	37	33	34	39	37	34	69	61	52	40	38	36	39	44	41	39	70	64	56	44	41	39	44	49	45	44												
	1680	6048	78	65	50	45	42	41	41	45	44	40	78	67	57	50	49	46	46	50	49	45	78	70	61	52	50	47	50	54	51	49												

< indicates values below 15

TVZ Air-Regenerated Noise with TS

Table 7: Insertion loss

Type / Size	D _e in dB							
	f _m in Hz							
	63	125	250	500	1000	2000	4000	8000
TVZ 125 to 200 without TS	15	18	26	37	42	39	32	23
TVZ 125 to 200 with TS	21	25	32	47	47	45	37	29
TVZ 250 to 400 without TS	20	25	31	45	45	42	37	31
TVZ 250 to 400 with TS	25	32	42	53	52	50	45	38
TVA 125 to 400 without TS	15	21	27	35	41	39	32	23
TVA 125 to 400 with TS	18	30	35	48	48	46	40	33

Table 8

Size	V		Δp _{st} = 200 Pa										Δp _{st} = 500 Pa										Δp _{st} = 1000 Pa																				
			L _w in dB										L _w in dB										L _w in dB																				
			f _m in Hz										f _m in Hz										f _m in Hz																				
			63	125	250	500	1000	2000	4000	8000	L in dB(A)	NC	63	125	250	500	1000	2000	4000	8000	L in dB(A)	NC	63	125	250	500	1000	2000	4000	8000	L in dB(A)	NC											
125	15	54	53	29	21	<	<	<	<	<	<	<	<	<	<	<	<	<	<	<	54	28	21	<	<	<	<	<	<	<	<	<	58	33	28	<	<	<	<	<	19	<	15
	35	126	55	39	30	<	<	<	<	15	<	<	58	37	31	<	<	<	<	<	16	<	<	61	38	34	15	<	<	<	<	22	18	18									
	60	216	49	43	32	16	<	<	<	15	<	<	51	42	36	16	<	<	<	15	16	<	57	43	38	17	<	<	<	23	20	19											
	95	342	54	47	38	16	<	<	<	<	18	<	55	54	42	19	<	<	<	20	24	16	60	51	43	21	15	<	<	19	24	16											
	150	540	57	50	46	27	22	19	<	<	26	20	58	55	49	28	23	18	<	21	29	23	63	56	47	25	18	<	18	29	28	25											
160	25	90	51	41	22	<	<	<	<	<	<	<	53	33	22	<	<	<	<	<	<	<	57	36	28	<	<	<	<	17	<	<											
	65	234	50	44	33	15	<	<	<	15	16	<	52	45	34	15	<	<	<	18	17	<	56	46	36	16	<	<	<	24	20	20											
	100	360	53	49	34	15	<	<	<	16	19	<	54	50	38	20	<	<	<	18	21	<	58	52	40	21	<	<	<	25	24	21											
	170	612	55	52	45	19	<	<	<	15	26	20	58	56	45	23	15	<	<	21	27	20	62	58	46	25	16	<	<	28	29	24											
	250	900	63	57	46	25	20	16	<	17	28	21	64	62	49	30	25	20	<	25	32	26	67	63	51	31	24	20	17	31	34	27											
200	40	144	49	28	18	<	<	<	<	<	<	<	40	29	21	<	<	<	<	<	<	<	52	33	25	<	<	<	<	<	<	<											
	110	393	45	37	26	15	<	<	<	<	<	<	53	40	29	18	<	<	<	<	15	<	56	42	31	21	<	<	<	18	18	<											
	180	648	48	41	28	15	<	<	<	<	15	<	56	45	33	20	<	<	<	<	19	<	59	46	36	23	<	<	<	20	22	16											
	280	1008	53	44	32	21	<	<	<	<	18	<	56	49	39	24	15	<	<	15	24	15	62	52	41	28	15	<	<	21	26	17											
	405	1458	61	52	41	29	21	<	<	<	26	17	62	53	43	35	29	23	17	18	30	20	66	56	46	35	24	18	<	24	31	23											
250	60	216	40	32	16	<	<	<	<	<	<	<	44	36	18	<	<	<	<	<	<	<	53	37	25	<	<	<	<	19	15	15											
	170	612	46	35	21	<	<	<	<	<	<	<	47	40	27	15	<	<	<	<	15	<	53	43	30	16	<	<	<	17	18	<											
	280	1008	48	41	23	15	<	<	<	<	15	<	53	46	31	16	<	<	<	19	20	15	56	49	35	19	<	<	<	21	23	17											
	470	1692	54	46	31	22	17	<	<	20	20	16	57	53	37	28	23	18	<	23	26	19	63	57	42	26	21	18	17	27	30	24											
	615	2214	61	52	38	28	24	21	20	28	27	24	64	56	44	37	33	29	24	31	33	27	67	60	47	34	30	27	21	34	35	30											
315	105	378	39	33	22	<	<	<	<	<	<	<	47	34	26	<	<	<	<	16	<	<	53	36	29	<	<	<	<	23	18	19											
	265	954	51	43	31	<	<	<	<	20	19	16	50	47	36	15	<	<	17	28	24	24	58	47	37	19	16	<	17	31	26	27											
	420	1512	51	45	32	<	<	<	<	23	21	19	59	54	40	20	19	17	19	31	29	27	61	53	42	24	21	19	21	34	30	30											
	720	2592	58	48	34	18	15	<	17	31	26	27	63	56	42	29	26	23	24	36	32	31	66	60	47	30	27	23	27	38	36	33											
	1025	3690	65	54	44	28	25	22	23	32	31	28	70	61	46	39	35	31	31	39	38	34	71	64	51	37	33	30	34	42	40	37											
400	170	612	39	34	23	<	<	<	<	<	<	<	39	39	28	<	<	<	<	21	17	17	49	42	32	17	<	<	20	29	23	25											
	445	1602	49	44	28	<	<	<	<	20	20	16	53	49	40	19	17	17	24	31	28	27	54	50	41	25	22	21	31	40	33	35											
	710	2556	52	47	30	18	15	15	20	26	23	22	56	52	41	24	21	20	27	34	30	30	59	55	44	28	25	24	34	42	36	37											
	1250	4500	65	52	38	29	27	23	27	35	31	31	67	57	43	31	29	26	32	40	36	35	68	60	47	34	31	29	27	45	39	40											
	1680	6048	76	61	41	35	32	31	34	41	40	37	76	63	48	41	40	36	39	46	43	41	76	66	52	42	40	37	43	50	45	45											

< indicates values below 15

TVZ Air-Regenerated Noise with Reheat Coil

without TS

Example

Given: TVZ size 160 with reheat coil 4RR
 \dot{V} = 65 to 250 l/s or 234 to 900 m³/h
 Δp_{st} = 500 Pa
 ΔL = 3 dB

Specified sound pressure level in room
 50 dB(A) with 8 dB/oct. room attenuation

Required: Air-regenerated noise in room as dB(A) value
 at \dot{V} = 250 l/s or 900 m³/h

Result: $L = 44 \text{ dB(A)} + 3 \text{ dB} = 47 \text{ dB(A)}$,
 Specification is met

Correction Values

Number of rows	1RR	2RR	4RR ¹⁾
ΔL in dB or NC	- 2	0	3

1) Note minimum pressure differential as in table 3.

Table 9

Size	\dot{V}		$\Delta p_{st} = 200 \text{ Pa}$														$\Delta p_{st} = 500 \text{ Pa}$														$\Delta p_{st} = 1000 \text{ Pa}$													
			L_w in dB														L_w in dB														L_w in dB													
			f_m in Hz														f_m in Hz														f_m in Hz													
			63	125	250	500	1000	2000	4000	8000	L in dB(A)	NC	63	125	250	500	1000	2000	4000	8000	L in dB(A)	NC	63	125	250	500	1000	2000	4000	8000	L in dB(A)	NC												
125	15	54	55	32	25	16	<	<	<	19	<	15	56	31	25	16	<	<	<	22	15	18	60	37	33	20	<	<	19	26	20	22												
	35	126	57	43	35	18	<	<	<	21	17	17	60	41	36	23	<	<	<	23	19	19	63	42	39	26	15	<	21	30	24	26												
	60	216	51	47	37	24	17	15	15	22	20	18	53	46	41	27	19	17	17	22	23	18	59	47	43	31	22	20	23	31	27	27												
	95	342	57	51	44	33	30	27	25	23	28	20	58	58	47	35	31	28	26	29	31	25	62	55	48	37	32	29	29	28	32	24												
	150	540	61	56	52	45	42	39	35	33	39	32	62	60	55	44	41	38	37	35	39	31	66	61	53	46	42	39	38	39	40	34												
160	25	90	53	45	29	17	<	<	<	19	16	15	55	37	29	20	16	<	<	19	16	15	59	40	35	23	16	15	16	23	20	19												
	65	234	52	48	40	23	<	<	<	20	22	16	54	49	41	28	17	<	<	23	24	19	58	50	43	30	18	17	20	30	27	26												
	100	360	55	53	41	27	21	19	20	21	25	17	56	54	45	34	27	24	22	23	29	20	60	56	47	36	28	25	26	31	31	27												
	170	612	58	56	52	37	33	31	29	27	34	28	60	60	52	40	35	32	30	30	36	28	64	62	53	42	36	34	32	35	37	31												
	250	900	66	62	55	47	44	42	40	38	41	35	67	66	57	49	46	44	41	40	44	37	70	67	59	50	46	44	43	42	45	37												
200	40	144	51	32	26	17	15	<	<	15	<	<	42	33	29	19	19	<	<	23	17	19	54	37	33	23	20	17	21	27	22	23												
	110	393	47	41	34	22	15	<	<	<	19	<	55	44	37	28	17	<	<	22	22	18	58	46	39	31	20	17	17	31	26	27												
	180	648	50	46	37	30	27	25	22	19	26	18	58	49	42	33	28	26	23	26	28	22	61	50	44	36	30	27	25	33	31	29												
	280	1008	57	51	45	41	39	37	34	31	36	30	29	54	49	43	40	38	36	34	38	31	65	57	51	44	41	39	37	37	40	32												
	405	1458	67	61	56	53	51	49	47	45	48	42	67	62	57	55	52	51	49	46	50	43	70	64	59	56	53	52	50	48	51	44												
250	60	216	42	36	26	20	20	17	15	19	18	15	46	40	28	17	21	20	17	21	20	17	55	41	35	24	23	18	16	26	23	22												
	170	612	48	39	31	23	20	17	15	15	19	<	49	44	37	28	21	19	17	19	23	15	55	47	40	30	24	21	19	24	26	20												
	280	1008	51	46	38	34	31	30	27	24	29	23	56	51	43	36	33	31	29	28	32	24	58	53	46	38	34	32	30	30	34	26												
	470	1692	61	56	51	49	47	45	43	40	44	38	62	59	53	50	48	46	44	42	45	39	66	62	56	52	49	47	45	43	47	40												
	615	2214	68	64	60	58	56	54	52	50	53	47	70	65	61	59	57	55	54	51	54	48	72	67	63	60	58	56	55	53	56	49												
315	105	378	41	37	31	19	22	19	17	<	20	<	49	38	35	25	19	16	<	22	21	18	55	40	38	26	22	15	18	29	25	25												
	265	954	53	47	40	29	22	19	17	25	26	21	52	51	45	29	27	24	27	34	31	30	60	51	46	32	29	26	27	37	33	32												
	420	1512	54	50	43	35	33	32	29	30	32	26	61	58	49	38	36	34	33	37	37	32	63	57	51	40	38	35	35	40	39	35												
	720	2592	62	57	52	49	48	46	44	42	45	39	66	61	55	50	49	47	45	45	47	40	69	65	58	52	50	48	47	47	49	42												
	1025	3690	70	65	61	59	58	56	54	52	55	49	73	68	63	60	59	57	56	54	57	50	73	70	65	61	60	58	57	55	58	51												
400	170	612	41	38	33	21	22	20	17	<	21	<	41	43	37	27	19	16	20	25	24	21	51	46	41	28	22	15	27	33	29	29												
	445	1602	51	48	38	28	26	24	23	24	27	20	55	53	49	32	29	28	31	35	34	31	56	54	50	29	33	30	38	44	39	39												
	710	2556	55	52	43	39	38	36	34	33	36	29	59	56	51	41	39	38	37	39	39	34	61	59	53	43	41	34	41	46	42	41												
	1250	4500	68	60	56	54	53	51	49	47	50	44	70	63	58	55	54	52	50	49	52	45	71	66	60	56	55	53	52	52	53	47												
	1680	6048	78	69	65	63	62	60	59	57	60	53	79	71	67	64	63	62	60	58	61	54	76	73	68	65	64	63	61	60	62	55												

< indicates values below 15

TVZ Air-Regenerated Noise with Reheat Coil with TS

Correction Values

Number of rows (RR)	1RR	2RR	4RR ¹⁾
ΔL in dB or NC	- 2	0	3

1) Note minimum pressure differential as in table 3.

Component layout, in the direction of the air flow, when measuring acoustic data:
TVZ-box, reheat coil, TS attenuator

Table 10

Size	V		$\Delta p_{st} = 200$ Pa											$\Delta p_{st} = 500$ Pa											$\Delta p_{st} = 1000$ Pa										
			L_w in dB											L_w in dB											L_w in dB										
			f_m in Hz											f_m in Hz											f_m in Hz										
			63	125	250	500	1000	2000	4000	8000	L in dB(A)	NC	63	125	250	500	1000	2000	4000	8000	L in dB(A)	NC	63	125	250	500	1000	2000	4000	8000	L in dB(A)	NC			
l/s	m ³ /h	63	125	250	500	1000	2000	4000	8000	L in dB(A)	NC	63	125	250	500	1000	2000	4000	8000	L in dB(A)	NC	63	125	250	500	1000	2000	4000	8000	L in dB(A)	NC				
125	15	54	54	31	17	<	<	<	<	<	<	55	30	17	<	<	<	<	<	<	<	59	36	27	<	<	<	<	15	<	<				
	35	126	56	42	29	<	<	<	<	<	<	59	40	30	16	<	<	<	<	<	<	62	41	33	17	<	<	<	19	17	15				
	60	216	50	46	31	16	<	<	<	<	15	52	45	35	18	<	<	<	<	16	<	58	46	37	20	<	<	<	20	19	16				
	95	342	56	50	38	23	<	<	<	<	20	57	57	41	25	16	<	<	<	18	25	18	61	54	42	27	16	<	<	17	24	15			
	150	540	60	55	46	34	25	<	<	21	28	20	61	59	49	33	24	<	<	23	30	23	65	60	47	35	25	<	<	27	30	23			
160	25	90	50	42	21	<	<	<	<	<	<	52	34	21	<	<	<	<	<	<	<	56	37	27	<	<	<	<	<	<					
	65	234	49	45	32	<	<	<	<	15	<	51	46	33	17	<	<	<	<	16	<	55	47	35	18	<	<	<	17	18	<				
	100	360	52	50	33	16	<	<	<	19	<	53	51	37	22	<	<	<	<	21	<	57	53	39	24	<	<	<	18	23	<				
	170	612	55	53	44	24	17	<	<	15	25	18	57	57	44	27	19	<	<	17	27	19	61	59	45	29	20	<	<	21	29	22			
	250	900	63	59	47	34	27	18	<	24	31	22	64	63	49	36	29	19	18	26	33	27	67	64	51	37	29	20	16	28	35	28			
200	40	144	47	28	<	<	<	<	<	15	<	38	29	19	<	<	<	<	<	<	<	50	33	23	<	<	<	15	<	<					
	110	393	43	37	24	15	<	<	<	<	<	51	40	27	<	<	<	<	<	<	<	54	42	29	17	<	<	<	19	17	15				
	180	648	47	42	28	16	<	<	<	15	<	54	45	32	19	<	<	<	<	18	<	57	46	34	21	<	<	<	18	21	<				
	280	1008	53	47	35	26	21	16	<	16	22	55	50	39	28	22	17	<	18	25	15	61	53	41	30	23	18	<	22	27	18				
	405	1458	63	57	46	38	33	27	20	29	33	25	63	58	47	40	34	29	21	30	34	26	66	60	49	41	35	30	22	32	36	28			
250	60	216	40	31	<	<	<	<	<	15	<	44	35	16	<	<	<	<	15	<	<	53	36	22	<	<	<	15	<	<					
	170	612	46	34	19	<	<	<	<	<	<	47	39	25	<	<	<	<	<	<	<	53	42	27	15	<	<	<	16	<	<				
	280	1008	49	41	25	15	<	<	<	15	<	54	46	30	15	<	<	<	15	19	<	53	48	33	16	<	<	<	17	21	<				
	470	1692	59	51	38	25	18	16	16	25	26	21	60	54	40	26	18	17	17	27	28	23	64	57	43	28	19	18	18	28	31	24			
	615	2214	66	59	47	34	26	25	25	35	34	31	68	60	48	35	27	26	26	36	35	31	70	62	50	36	28	27	27	38	37	33			
315	105	378	38	33	21	<	<	<	<	<	<	46	34	25	<	<	<	<	<	<	<	52	36	28	<	<	<	18	16	<					
	265	954	51	43	30	<	<	<	<	16	18	<	49	47	35	<	<	<	23	22	19	57	47	36	<	<	<	26	24	22					
	420	1512	51	46	33	16	<	<	<	20	21	16	58	54	39	19	15	<	15	26	28	22	60	53	41	21	16	15	17	29	29	25			
	720	2592	59	53	42	29	25	24	25	31	30	27	63	57	45	31	26	25	27	34	33	30	66	61	50	32	27	26	28	36	37	31			
	1025	3690	67	61	51	39	35	34	35	41	39	36	70	64	53	40	36	35	37	43	41	38	71	66	55	41	37	36	38	44	43	39			
400	170	612	37	34	25	<	<	<	<	<	<	37	39	29	<	<	<	<	17	16	<	47	42	33	<	<	<	16	25	21	21				
	445	1602	47	44	30	<	<	<	<	17	19	<	51	49	41	17	<	15	21	27	27	23	52	50	42	21	17	17	27	36	30	31			
	710	2556	51	48	35	24	21	21	23	25	25	21	55	52	43	25	23	23	26	31	30	27	57	55	45	27	24	24	31	38	34	33			
	1250	4500	64	56	48	38	36	36	38	39	38	34	66	59	50	39	37	37	39	41	40	36	67	62	52	40	38	38	41	44	42	39			
	1680	6048	74	65	57	47	45	45	48	49	47	44	75	67	59	48	46	47	49	50	49	45	75	69	60	50	47	48	50	52	50	47			

< indicates values below 15

TVZ Case-Radiated Noise

Example

Given: TVZ Size 200
 $V = 100$ to 278 l/s or 360 to 1000 m³/h
 $\Delta p_{st} = 500$ Pa
 Specified sound pressure level in room 35 dB(A)
 with 4 dB/oct. room attenuation and 4 dB/oct.
 ceiling reduction

Required: Case-radiated noise in room
 at $V = 278$ l/s or 1000 m³/h

Calculation

f_m	63	125	250	500	1000	2000	4000	8000
L_{w1} (without acoustic cladding)	55	52	50	44	39	37	35	37
Ceiling noise reduction	4	4	4	4	4	4	4	4
Room attenuation	4	4	4	4	4	4	4	4
	47	44	42	36	31	29	27	29
A-Weighting*	-26	-16	-9	-3	0	+1	+1	-1
Corrected level	21	28	33	33	31	30	28	28

* see e.g. VDI 2081

Result: L approx. 39 dB(A) based on logarithmic addition, specification is not met. TS attenuator required (For calculation see page 13).

Table 11

Size	V		$\Delta p_{st} = 200$ Pa														$\Delta p_{st} = 500$ Pa														$\Delta p_{st} = 1000$ Pa													
			L_{w1} in dB														L_{w1} in dB														L_{w1} in dB													
			f_m in Hz														f_m in Hz														f_m in Hz													
			63	125	250	500	1000	2000	4000	8000	L_1 in dB(A)	NC	63	125	250	500	1000	2000	4000	8000	L_1 in dB(A)	NC	63	125	250	500	1000	2000	4000	8000	L_1 in dB(A)	NC												
125	15	54	27	31	27	26	27	20	<	<	22	17	20	35	28	27	28	25	24	22	25	19	36	37	29	27	29	27	27	27	27	23												
	35	126	34	40	32	30	27	21	<	16	24	17	29	41	36	34	32	29	26	23	29	22	37	42	37	35	36	34	33	30	33	27												
	60	216	38	42	35	30	27	23	16	20	26	18	38	46	40	37	34	31	27	25	32	24	42	47	41	40	40	37	35	26	36	30												
	95	342	42	46	40	33	29	26	21	21	29	20	46	50	43	40	36	33	29	27	35	26	47	51	46	43	42	39	37	34	39	32												
	150	540	47	49	45	40	34	31	25	25	34	27	51	54	46	43	38	34	32	29	37	30	52	56	49	46	44	40	40	37	42	34												
160	25	90	25	28	25	26	24	18	<	16	20	<	21	33	28	28	29	28	24	24	26	21	29	31	29	28	32	27	27	30	28	25												
	65	234	34	38	34	30	26	22	15	22	25	19	35	41	37	35	33	31	27	27	31	24	39	42	39	37	39	35	33	33	35	29												
	100	360	39	42	37	31	27	25	19	22	27	18	44	46	41	38	35	32	28	29	33	25	46	47	43	41	41	38	36	35	38	31												
	170	612	48	45	42	35	29	28	23	27	30	22	49	50	46	42	37	35	32	32	36	28	52	52	48	46	43	41	40	38	41	34												
	250	900	51	49	48	42	35	32	28	32	36	28	55	54	51	47	40	36	35	35	40	34	58	56	53	51	45	42	42	40	44	38												
200	40	144	31	32	30	29	25	21	18	22	23	18	27	34	34	36	33	30	26	26	30	23	30	32	33	34	38	30	28	31	32	28												
	110	393	40	42	38	32	28	24	21	25	27	20	45	43	41	40	36	32	29	30	34	26	40	44	42	42	40	38	35	36	38	31												
	180	648	46	44	41	33	29	27	27	29	30	25	49	48	46	42	37	34	32	33	36	29	52	50	48	46	44	40	33	39	41	35												
	280	1008	51	47	46	36	31	30	28	30	33	26	55	52	50	44	39	37	35	37	39	32	58	55	53	50	46	42	35	42	44	37												
	405	1458	56	53	53	46	38	36	35	38	40	33	60	56	54	51	43	40	40	42	44	38	63	59	57	54	48	44	45	46	48	42												
250	60	216	28	33	32	30	27	21	<	<	24	17	36	36	35	34	33	31	26	23	30	24	35	37	39	38	37	36	33	32	35	28												
	170	612	46	42	39	32	28	24	17	19	27	18	47	46	44	41	36	33	29	27	35	27	50	48	46	44	42	40	38	36	40	32												
	280	1008	52	46	40	33	29	26	21	23	29	19	53	51	47	42	37	35	32	32	37	28	56	54	51	48	48	41	40	40	44	39												
	470	1692	54	51	44	37	31	30	27	28	33	24	58	56	51	44	39	38	36	37	40	32	61	59	55	50	49	43	43	44	46	40												
	615	2214	58	54	51	45	35	36	32	34	39	31	62	59	55	50	42	40	40	41	44	37	65	63	59	54	51	45	46	47	50	43												
315	105	378	35	36	31	29	26	20	<	<	23	16	40	38	38	37	34	32	28	22	32	25	39	38	41	39	37	36	36	32	36	31												
	265	954	49	44	38	33	29	24	20	<	28	19	50	49	46	42	38	35	33	29	37	28	49	51	50	48	44	42	41	39	43	36												
	420	1512	52	46	42	34	29	27	24	20	30	21	56	53	50	45	40	38	36	33	40	32	59	56	55	51	48	44	44	42	46	39												
	720	2592	58	51	47	42	33	33	29	30	36	28	61	58	55	48	42	41	40	37	44	36	64	61	59	54	50	46	47	44	49	42												
	1025	3690	64	55	53	44	36	39	35	34	41	34	68	62	57	51	43	42	43	39	46	38	71	65	62	56	50	47	49	46	51	44												
400	170	612	40	40	36	33	30	26	19	15	27	20	44	42	42	39	37	36	32	22	35	39	47	44	46	44	41	41	40	36	40	35												
	445	1602	52	45	43	35	30	28	23	15	31	22	57	53	52	46	39	39	38	30	41	33	57	54	46	54	48	46	46	39	47	41												
	710	2556	56	47	43	35	32	32	27	30	33	25	59	56	55	47	41	40	40	31	43	36	62	59	59	55	49	46	48	40	49	43												
	1250	4500	67	52	47	39	34	37	32	30	38	32	67	59	55	48	42	42	43	31	44	37	69	63	61	56	50	47	50	41	51	44												
	1680	6048	77	62	55	48	37	41	37	36	46	48	79	63	58	51	42	44	46	36	49	51	79	66	62	57	48	47	50	43	52	51												

< indicates values below 15

TVZ Air-Regenerated Noise in High Pressure Duct

Table 13

Size	V		$\Delta p_{st} = 200 \text{ Pa}$										$\Delta p_{st} = 500 \text{ Pa}$										$\Delta p_{st} = 1000 \text{ Pa}$									
			L _{WR} in dB										L _{WR} in dB										L _{WR} in dB									
			f _m in Hz										f _m in Hz										f _m in Hz									
			63	125	250	500	1000	2000	4000	8000	L _{WR} in dB(A)	NC _R	63	125	250	500	1000	2000	4000	8000	L _{WR} in dB(A)	NC _R	63	125	250	500	1000	2000	4000	8000	L _{WR} in dB(A)	NC _R
125	15	54	79	55	53	50	46	44	34	27	55	63	76	56	50	47	47	51	46	39	56	58	79	54	51	47	47	52	52	47	59	63
	35	126	78	68	61	55	49	46	37	30	59	61	77	66	60	57	53	55	49	42	61	60	82	65	59	54	52	56	56	50	63	67
	60	216	84	77	66	58	49	48	41	33	65	71	83	76	69	63	57	56	53	45	67	69	84	74	68	62	58	60	60	53	68	71
	95	342	87	84	75	61	52	51	46	40	71	76	90	85	78	68	59	58	55	49	74	80	27	82	77	69	63	63	63	57	74	74
	150	540	92	86	80	71	60	57	51	45	76	83	95	89	84	74	64	61	59	53	79	87	95	87	83	76	68	65	65	60	79	87
160	25	90	67	61	56	54	43	40	35	27	54	50	66	59	54	53	47	49	43	38	55	50	67	57	50	48	46	49	47	44	55	50
	65	234	71	70	64	56	46	44	37	32	59	58	72	71	67	63	55	53	49	44	64	60	72	69	64	60	55	57	57	52	64	59
	100	360	71	75	67	57	48	46	41	36	63	65	72	76	70	65	56	55	52	47	67	66	76	77	70	66	61	61	60	55	70	67
	170	612	80	80	77	61	51	50	45	41	70	71	85	81	77	69	58	58	56	52	72	72	86	80	77	71	65	64	64	60	74	73
	250	900	88	82	85	71	60	57	52	48	77	81	93	87	88	75	63	61	60	57	81	84	92	86	85	76	68	67	67	63	80	83
200	40	144	59	62	57	50	45	41	35	27	53	48	60	57	53	50	52	50	48	41	57	51	70	57	52	49	53	53	53	48	59	55
	110	393	78	70	62	55	48	46	40	36	60	61	72	68	63	59	55	53	51	47	62	56	74	67	60	57	59	58	58	55	65	60
	180	648	80	74	64	54	49	48	45	41	62	64	84	77	69	63	57	55	54	50	67	70	80	74	67	62	63	60	60	57	69	64
	280	1008	84	77	72	58	52	52	49	47	67	70	87	80	75	65	59	59	56	55	71	75	90	82	77	69	67	63	64	61	75	80
	405	1458	90	80	81	69	61	59	54	50	75	80	93	84	82	73	64	63	63	61	77	84	93	85	83	75	70	67	68	66	79	84
250	60	216	59	56	52	45	44	40	35	29	50	43	67	57	51	47	52	50	46	39	56	51	68	54	50	47	52	52	51	46	58	53
	170	612	80	67	64	50	47	45	40	33	59	65	78	70	65	59	56	54	52	48	64	62	76	67	62	58	62	60	59	55	67	62
	280	1008	84	72	64	52	48	47	43	39	62	71	85	76	69	61	56	55	55	50	67	72	82	74	68	63	64	61	63	58	70	68
	470	1692	84	69	65	55	51	50	46	41	62	71	91	77	74	64	58	58	58	53	71	81	90	80	77	69	66	63	66	63	75	80
	615	2214	80	64	60	59	58	49	45	37	62	65	95	80	75	68	63	61	61	56	74	87	94	84	80	72	68	65	67	64	77	86
315	105	378	63	56	50	45	45	42	34	27	50	44	54	55	49	49	50	49	45	40	55	50	60	55	48	49	52	51	49	45	57	52
	265	954	79	70	63	53	46	46	40	37	60	63	78	71	64	62	58	55	52	48	65	62	75	68	61	63	63	60	60	56	68	62
	420	1512	77	70	60	49	47	48	43	39	58	60	86	77	69	64	58	56	55	51	68	74	82	75	68	68	66	62	63	59	72	68
	720	2592	83	74	64	53	51	52	47	43	63	69	87	78	71	64	58	60	59	55	69	75	90	82	75	72	67	64	66	63	75	80
	1025	3690	83	77	70	63	57	56	49	44	67	69	92	82	74	68	61	61	62	57	73	83	95	85	78	74	68	66	69	65	78	88
400	170	612	69	57	52	46	46	44	38	33	52	48	64	54	52	53	53	52	48	43	58	53	64	54	53	54	56	55	54	51	61	56
	445	1602	77	67	57	49	47	48	43	40	57	60	78	68	65	60	56	57	54	51	64	62	77	67	66	66	64	62	62	60	70	64
	710	2556	78	68	58	50	50	51	46	46	59	62	83	73	67	62	57	59	57	55	67	69	82	73	69	68	65	63	65	63	72	68
	1250	4500	83	68	60	51	51	52	49	45	61	69	88	77	68	62	58	61	60	58	69	77	90	80	74	70	65	65	68	66	75	80
	1680	6048	86	66	61	62	60	51	46	39	65	74	93	79	72	66	61	62	63	60	72	85	93	83	77	73	67	66	69	67	77	85

< indicates values below 15

TVA Air-Regenerated Noise in High Pressure Duct

Table 14

Size	V		$\Delta p_{st} = 200 \text{ Pa}$											$\Delta p_{st} = 500 \text{ Pa}$											$\Delta p_{st} = 1000 \text{ Pa}$										
			L _{WR} in dB											L _{WR} in dB											L _{WR} in dB										
			f _m in Hz											f _m in Hz											f _m in Hz										
			63	125	250	500	1000	2000	4000	8000	L _{WR} in dB(A)	NC _R	63	125	250	500	1000	2000	4000	8000	L _{WR} in dB(A)	NC _R	63	125	250	500	1000	2000	4000	8000	L _{WR} in dB(A)	NC _R			
l/s	m ³ /h	63	125	250	500	1000	2000	4000	8000	L _{WR} in dB(A)	NC _R	63	125	250	500	1000	2000	4000	8000	L _{WR} in dB(A)	NC _R	63	125	250	500	1000	2000	4000	8000	L _{WR} in dB(A)	NC _R				
125	15	54	76	56	47	36	29	30	27	22	51	58	75	50	47	38	33	33	36	34	50	57	80	55	49	41	39	40	41	43	55	64			
	35	126	81	70	58	48	42	42	37	30	58	66	84	73	63	54	48	47	43	38	62	71	88	72	66	57	51	47	46	45	64	77			
	60	216	86	77	65	53	48	48	45	38	65	74	90	79	69	59	54	53	52	47	68	80	91	80	73	63	58	57	57	53	71	81			
	95	342	90	80	75	59	53	52	52	45	70	80	94	85	77	65	60	58	60	55	74	86	96	86	79	69	64	62	64	61	76	89			
	150	540	87	80	73	64	55	50	53	44	69	75	97	89	81	72	66	60	65	59	78	90	98	89	79	73	66	69	65	65	79	92			
160	25	90	66	48	48	36	27	25	22	19	43	43	72	54	51	40	33	32	31	29	48	52	79	59	56	46	38	39	40	39	55	63			
	65	234	71	72	63	53	44	48	44	37	60	61	78	73	67	60	50	51	48	43	63	62	84	72	68	60	53	51	49	47	64	70			
	100	360	78	77	66	56	48	54	52	46	64	67	89	80	72	64	55	57	58	54	70	78	91	82	75	68	61	60	62	57	73	81			
	170	612	86	79	73	59	53	56	59	52	69	73	93	84	77	68	59	61	65	61	74	84	96	88	81	72	66	64	69	66	78	89			
	250	900	77	76	70	61	58	54	56	48	66	66	98	88	79	73	65	62	68	66	78	92	99	92	84	77	71	67	73	71	82	93			
200	40	144	62	60	50	43	35	29	24	18	48	45	78	63	55	49	44	39	36	34	55	61	75	61	56	50	47	45	44	43	55	57			
	110	393	78	68	56	52	47	46	40	34	57	61	78	73	60	55	53	48	45	40	61	62	79	73	65	58	58	54	52	49	64	63			
	180	648	81	72	60	54	49	54	50	46	62	66	84	78	66	61	58	59	54	51	67	70	84	80	69	63	62	59	56	52	69	71			
	280	1008	85	75	64	59	52	60	58	54	67	72	89	81	70	65	60	63	63	61	72	78	91	84	76	69	66	65	65	64	75	81			
	405	1458	84	74	68	64	57	57	55	51	67	70	97	83	74	71	64	66	68	68	77	90	96	89	80	75	70	69	71	72	80	89			
250	60	216	74	56	47	40	39	37	30	23	50	55	72	51	44	38	35	34	34	33	48	52	75	53	46	38	40	42	42	43	52	57			
	170	612	81	66	56	50	50	53	48	43	60	66	79	67	60	56	53	56	53	49	62	63	79	69	62	58	55	55	52	50	63	63			
	280	1008	84	74	60	55	53	59	53	50	65	71	86	77	66	62	57	62	61	58	69	74	88	77	69	65	61	63	65	61	72	77			
	470	1692	87	74	64	61	55	63	59	56	69	75	92	81	74	68	62	66	69	65	75	83	95	85	79	74	69	70	75	72	81	87			
	615	2214	89	76	69	68	61	65	62	59	72	78	97	84	75	74	66	68	74	70	79	90	98	89	83	79	72	73	79	77	85	92			
315	105	378	58	56	47	42	43	42	36	30	49	43	57	57	48	43	40	38	38	36	48	41	65	59	49	44	43	43	44	45	52	48			
	265	954	78	66	55	52	52	55	51	46	61	62	79	70	62	59	56	58	58	54	65	63	81	73	65	61	59	59	58	56	67	66			
	420	1512	82	70	58	56	56	61	56	53	66	68	86	76	57	64	60	63	65	61	71	74	88	79	71	69	65	65	69	66	75	77			
	720	2592	84	73	63	62	57	66	62	58	70	71	91	81	71	69	64	68	74	68	78	81	94	85	77	75	70	71	77	75	82	86			
	1025	3690	88	75	67	71	61	68	65	61	74	77	96	83	74	74	67	70	79	72	82	89	101	59	81	79	74	74	82	80	86	97			
400	170	612	71	55	49	42	41	39	35	30	49	51	69	57	53	47	44	42	42	40	52	48	70	58	53	49	49	48	48	48	56	51			
	445	1602	78	62	57	51	52	54	54	50	61	62	80	67	64	58	55	58	58	55	65	65	82	70	66	62	59	59	58	57	67	68			
	710	2556	82	65	61	56	56	59	61	58	66	68	85	72	68	63	60	63	66	64	71	72	88	76	72	68	64	65	69	67	75	77			
	1250	4500	88	69	67	61	58	63	67	64	72	77	92	77	74	68	65	68	73	73	78	83	95	82	80	75	70	71	77	78	83	88			
	1680	6048	96	75	73	39	63	67	71	70	77	89	98	80	78	73	68	69	76	77	82	92	101	85	83	79	74	74	81	83	87	97			

< indicates values below 15

TVA Air-Regenerated Noise

without TS

Example

Given: TVA Size 160
 \dot{V} = 170 l/s or 612 m³/h
 Δp_{st} = 200 Pa
 Specified sound pressure level in room 25 dB(A)
 with 4 dB/oct. room attenuation

Required: Air-regenerated noise L in room at
 170 l/s or 612 m³/h

Calculation

f_m	63	125	250	500	1k	2k	4k	8k
L_w	45	54	45	28	17	<	17	23
Reflection attenuation	14	9	4	1	0	0	0	0
Attenuation by duct ¹⁾	0	6	8	4	3	3		
Room attenuation ¹⁾	4	4	4	4	4	4	4	4
	27	41	37	17	5	<	10	16
A-Weighting	-26	-16	-9	-3	0	+1	+1	-1
Corrected level ¹⁾	25	28	14	5	<	11	15	

1) see e.g. VDI 2081

Result: L approx. 30 dB(A) based on logarithmic addition, specification is not met. TS attenuator required (For calculation see page 17).

Table 15

Size	\dot{V}		$\Delta p_{st} = 200$ Pa														$\Delta p_{st} = 500$ Pa														$\Delta p_{st} = 1000$ Pa													
			L_w in dB														L_w in dB														L_w in dB													
			f_m in Hz														f_m in Hz														f_m in Hz													
			63	125	250	500	1000	2000	4000	8000	L in dB(A)	NC	63	125	250	500	1000	2000	4000	8000	L in dB(A)	NC	63	125	250	500	1000	2000	4000	8000	L in dB(A)	NC												
125	15	54	51	39	30	17	<	<	<	20	15	16	54	39	27	<	<	<	19	<	15	52	38	28	17	<	<	<	19	<	15													
	35	126	43	45	32	16	<	<	<	19	16	15	53	46	36	20	<	<	<	19	18	15	53	46	37	22	15	<	<	20	19	16												
	60	216	56	48	35	18	<	<	<	18	<	<	54	50	39	25	17	<	<	21	21	17	58	49	40	28	22	18	15	23	23	19												
	95	342	57	51	41	25	16	<	<	20	23	16	56	58	48	31	21	16	16	25	29	22	63	58	48	34	27	22	21	30	30	26												
	150	540	59	49	39	28	25	18	<	22	23	18	60	59	49	36	26	21	20	30	31	26	61	61	54	40	30	24	26	35	35	31												
160	25	90	42	30	28	17	<	<	<	18	<	<	57	38	26	<	<	<	16	18	15	<	46	36	30	18	<	<	<	18	<	<												
	65	234	47	49	36	23	<	<	<	18	20	<	44	50	41	29	<	<	<	18	23	15	44	50	42	32	18	<	<	19	25	17												
	100	360	43	53	41	26	<	<	<	18	24	15	45	57	47	33	18	<	15	22	29	22	46	58	49	37	23	18	19	27	32	24												
	170	612	45	54	45	28	17	<	17	23	27	20	49	61	51	37	24	18	22	32	34	28	50	64	55	42	28	22	28	37	38	32												
	250	900	46	49	41	31	26	19	16	21	25	17	56	65	51	42	30	24	26	37	37	32	62	67	56	46	34	27	32	43	41	38												
200	40	144	48	29	23	20	<	<	<	17	<	<	46	33	26	22	19	17	18	24	19	20	53	40	33	29	26	24	25	30	26	26												
	110	393	51	38	29	20	15	<	<	18	17	<	50	40	31	24	19	17	18	24	20	20	53	42	34	30	26	24	26	33	27	29												
	180	648	51	46	32	23	19	18	18	23	21	19	56	47	36	29	24	23	25	35	28	31	56	47	39	32	28	26	27	38	31	33												
	280	1008	55	46	38	27	25	23	23	31	27	27	60	53	44	32	28	27	27	37	32	32	61	55	45	37	32	20	31	38	34	33												
	405	1458	53	44	38	35	35	32	28	32	32	28	64	53	46	39	37	34	32	38	36	33	66	59	52	42	38	36	35	41	39	36												
250	60	216	47	29	24	19	15	<	15	21	16	17	46	31	28	23	19	18	19	24	20	20	51	39	32	28	25	25	29	25	25													
	170	612	46	41	30	22	17	16	17	22	19	18	49	43	35	27	21	21	21	25	23	21	52	43	37	30	26	25	26	31	27	27												
	280	1008	53	47	33	25	20	20	20	24	23	20	56	51	40	31	24	24	25	29	28	25	57	50	43	35	29	28	29	35	32	31												
	470	1692	51	47	36	31	28	25	23	27	27	23	61	56	45	37	32	29	31	35	34	31	63	59	50	41	34	32	36	41	38	36												
	615	2214	55	45	44	38	34	35	31	33	34	29	62	56	47	41	36	37	35	38	37	33	66	60	52	45	37	38	41	43	41	38												
315	105	378	45	37	26	<	<	<	<	17	<	<	49	39	28	15	<	<	<	16	<	<	48	36	29	22	19	<	15	19	18	15												
	265	954	49	50	37	22	20	<	17	20	25	17	66	51	39	31	25	20	24	24	29	20	61	50	41	35	30	23	26	28	30	24												
	420	1512	59	55	41	29	25	21	25	33	31	29	65	58	45	36	29	25	32	33	34	29	66	58	48	41	35	29	36	37	37	32												
	720	2592	61	55	45	36	31	26	30	35	34	31	71	61	50	41	35	29	40	39	40	34	73	65	55	47	30	34	45	46	44	41												
	1025	3690	65	49	42	43	40	36	36	38	38	33	72	61	52	47	42	37	45	44	44	39	77	67	58	51	45	41	52	51	49	46												
400	170	612	45	37	25	18	16	<	16	22	18	18	47	38	30	23	20	19	21	26	22	22	50	38	32	27	25	26	29	33	28	29												
	445	1602	53	43	31	21	20	19	23	26	23	22	56	49	39	28	25	24	29	32	29	28	57	51	42	33	30	28	33	38	33	33												
	710	2556	55	48	35	26	24	24	27	32	28	28	61	54	42	31	29	28	36	38	34	33	63	57	47	37	34	32	40	43	39	38												
	1250	4500	70	52	41	35	34	33	34	38	36	33	70	58	47	37	35	34	43	44	41	39	71	63	53	44	41	40	50	51	47	46												
	1680	6048	80	62	47	44	41	42	43	47	45	43	80	63	50	45	42	42	47	49	46	44	82	68	56	50	45	41	51	54	50	49												

< indicates values below 15

TVA Case-Radiated Noise

Example

Given: TVA Size 200
 \dot{V} = 100 to 280 l/s or 360 to 1008 m³/h
 Δp_{st} = 500 Pa
 Specified sound pressure level in room 35 dB(A)
 with 4 dB/oct. room attenuation and 4 dB/oct.
 ceiling reduction

Required: Case-radiated noise in room
 at \dot{V} = 280 l/s or 1008 m³/h

Calculation

f_m	63	125	250	500	1000	2000	4000	8000
L_{w1} (without acoustic cladding)	55	52	45	37	34	36	38	38
Ceiling noise reduction	4	4	4	4	4	4	4	4
Room attenuation	4	4	4	4	4	4	4	4
	47	44	37	29	26	28	30	30
A-Weighting*	-26	-16	-9	-3	0	+1	+1	-1
Corrected level	21	28	28	26	26	29	31	29

* see e.g. VDI 2081

Result: L_1 approx. 37 dB(A) based on logarithmic addition, specification not met. Acoustic cladding required (for calculation see page 19).

Table 17

Size	\dot{V}		$\Delta p_{st} = 200$ Pa														$\Delta p_{st} = 500$ Pa														$\Delta p_{st} = 1000$ Pa													
			L_{w1} in dB														L_{w1} in dB														L_{w1} in dB													
			f_m in Hz														f_m in Hz														f_m in Hz													
			63	125	250	500	1000	2000	4000	8000	L_1 in dB(A)	NC	63	125	250	500	1000	2000	4000	8000	L_1 in dB(A)	NC	63	125	250	500	1000	2000	4000	8000	L_1 in dB(A)	NC												
125	15	54	<	26	18	<	<	19	<	20	16	16	27	24	24	23	23	23	22	25	22	21	36	32	32	26	29	29	30	31	29	27												
	35	126	24	36	29	22	21	22	22	26	23	22	38	38	32	29	27	29	28	30	28	26	43	40	35	32	32	34	32	34	32	29												
	60	216	34	41	35	30	26	28	27	30	28	26	42	45	37	32	29	33	30	32	31	28	47	45	38	36	35	38	35	37	36	32												
	95	342	40	45	40	35	29	32	31	32	32	28	45	50	42	35	32	36	33	34	34	29	50	51	43	39	37	41	38	40	39	35												
	150	540	45	48	43	40	32	34	31	33	34	29	48	53	46	41	35	38	38	37	38	32	52	55	46	42	39	43	42	42	41	37												
160	25	90	23	29	20	15	<	15	<	19	15	15	24	28	22	20	20	22	20	24	21	20	34	32	27	24	26	27	27	30	26	26												
	65	234	36	39	29	24	21	22	20	24	22	20	36	39	32	27	26	28	26	28	27	24	42	40	35	31	30	33	32	34	31	29												
	100	360	42	43	34	28	24	27	25	27	27	23	42	45	37	31	29	32	30	31	31	27	47	45	40	35	33	37	35	37	35	33												
	170	612	47	47	38	33	28	31	29	32	31	28	49	51	42	37	33	36	34	36	35	31	52	52	45	40	35	40	39	40	39	35												
	250	900	48	50	42	38	32	33	32	34	34	29	55	56	47	42	36	39	39	40	40	35	55	57	49	44	40	43	42	43	42	38												
200	40	144	32	34	24	18	17	19	16	20	18	16	22	31	25	22	20	21	19	23	20	19	37	33	28	26	26	28	28	31	27	27												
	110	393	42	41	30	24	22	22	21	23	32	19	42	43	34	29	26	26	28	27	24	45	43	35	33	31	33	32	36	32	31													
	180	648	47	46	34	28	26	28	26	28	22	22	51	48	39	33	30	32	32	34	32	29	51	49	41	38	35	35	36	39	36	34												
	280	1008	48	48	39	32	29	32	31	33	32	29	55	52	45	37	34	36	38	38	37	33	56	57	47	41	38	39	42	42	41	37												
	405	1458	48	46	42	39	32	33	31	32	34	28	61	53	48	44	38	39	44	43	42	38	62	60	54	47	42	43	47	47	46	42												
250	60	216	25	32	<	<	<	<	<	<	<	<	32	33	<	<	18	18	<	<	16	<	31	33	22	16	25	29	24	23	25	22												
	170	612	43	45	29	21	<	24	17	20	24	17	47	45	33	29	27	29	26	24	28	22	47	45	36	34	33	33	31	32	32	28												
	280	1008	50	48	33	27	16	30	25	30	29	26	56	52	39	34	31	34	33	33	34	29	54	52	42	39	37	37	38	38	37	33												
	470	1692	50	48	38	33	31	34	29	31	32	27	59	55	45	41	37	38	39	37	39	33	62	58	51	47	42	41	45	44	44	39												
	615	2214	50	45	47	40	32	32	26	29	34	27	59	56	50	44	41	41	43	40	42	37	65	60	54	51	45	44	49	48	47	43												
315	105	378	28	31	15	16	15	15	<	15	15	<	39	34	19	18	24	25	20	20	22	18	37	34	28	27	27	35	29	30	30	28												
	265	954	47	40	29	25	25	28	23	26	26	22	50	44	37	32	31	34	33	31	32	28	46	44	40	39	36	39	37	37	37	32												
	420	1512	54	44	34	30	29	33	28	31	31	27	55	48	43	38	35	38	38	37	37	32	53	49	46	43	40	42	41	41	41	36												
	720	2592	60	50	42	36	35	38	34	37	36	32	60	53	48	42	40	42	44	42	42	39	61	55	53	48	44	47	46	46	46	41												
	1025	3690	64	54	48	43	38	40	37	39	40	34	62	55	52	46	43	44	45	44	44	39	66	59	56	52	47	50	52	50	50	46												
400	170	612	32	30	20	20	22	22	19	18	20	15	44	35	30	26	28	32	29	28	29	25	42	36	34	36	36	38	38	37	36	32												
	445	1602	45	37	32	28	28	32	30	28	29	25	51	43	42	36	34	38	40	39	37	34	49	45	45	42	40	42	43	43	41	38												
	710	2556	50	42	36	33	33	38	36	34	35	31	56	49	46	39	37	40	43	40	40	37	56	52	51	46	42	45	47	45	45	41												
	1250	4500	63	50	47	40	38	41	41	42	40	37	64	52	49	44	43	45	49	47	46	43	64	56	56	50	46	49	52	50	49	46												
	1680	6048	71	58	50	47	44	42	43	46	45	41	72	58	53	48	46	47	51	50	49	45	70	61	58	53	48	51	54	53	52	48												

< indicates values below 15

TVAD Case-Radiated Noise

Example

Given: TVAD Size 200
 $\dot{V} = 100$ to 280 l/s or 360 to 1008 m³/h
 $\Delta p_{st} = 500$ Pa
 Specified sound pressure level in room 35 dB(A)
 with 4 dB/oct. room attenuation and 4 dB/oct.
 ceiling reduction

Required: Case-radiated noise in room
 at $\dot{V} = 280$ l/s or 1008 m³/h

Calculation

f_m	63	125	250	500	1000	2000	4000	8000
L_{w1} (with acoustic cladding)	53	47	41	32	30	31	33	33
Ceiling noise reduction	4	4	4	4	4	4	4	4
Room attenuation	4	4	4	4	4	4	4	4
A-Weighting*	45	39	33	24	22	23	25	25
Corrected level	-26	-16	-9	-3	0	+1	+1	-1
Corrected level	19	23	24	21	22	24	26	24

* see e.g. VDI 2081

Result: L_1 approx. 32 dB(A) based on logarithmic addition, specification not met.

Table 18

Size	V		$\Delta p_{st} = 200$ Pa										$\Delta p_{st} = 500$ Pa										$\Delta p_{st} = 1000$ Pa									
			L_{w1} in dB										L_{w1} in dB										L_{w1} in dB									
			f_m in Hz										f_m in Hz										f_m in Hz									
			63	125	250	500	1000	2000	4000	8000	L_1 in dB(A)	NC	63	125	250	500	1000	2000	4000	8000	L_1 in dB(A)	NC	63	125	250	500	1000	2000	4000	8000	L_1 in dB(A)	NC
125	15	54	<	20	<	<	<	<	<	15	<	<	24	18	18	16	19	18	17	20	17	16	33	26	26	19	25	24	25	26	24	22
	35	126	21	30	23	15	17	17	17	21	17	17	35	32	26	22	23	24	23	25	23	21	40	34	29	25	28	29	27	29	27	25
	60	216	31	35	29	23	22	23	22	25	23	21	39	39	31	25	25	28	25	27	26	23	44	39	32	29	31	33	30	32	31	28
	95	342	37	39	34	28	25	27	26	27	26	23	42	44	36	28	28	31	28	29	29	25	47	45	37	32	33	36	33	35	34	30
	150	540	42	42	37	33	28	29	26	28	29	24	45	47	40	34	31	33	33	32	33	28	49	49	40	35	35	38	37	37	36	32
160	25	90	21	23	15	<	<	<	<	<	<	22	22	17	<	16	17	15	19	15	16	32	26	22	18	22	22	22	25	21	21	
	65	234	34	33	24	18	17	17	15	19	17	15	34	33	27	21	22	23	21	23	22	19	40	34	30	25	26	28	27	29	27	25
	100	360	40	37	29	22	20	22	20	22	21	18	40	39	32	25	25	27	25	26	26	22	45	39	35	29	29	32	30	32	30	28
	170	612	45	41	33	27	24	26	24	27	26	23	47	45	37	31	29	31	29	31	30	27	50	46	40	34	31	35	34	35	34	30
	250	900	46	44	37	32	28	28	27	29	29	25	53	50	42	36	32	34	34	35	34	30	53	51	44	38	36	38	37	38	37	33
200	40	144	30	29	20	<	<	<	<	15	<	<	20	26	21	17	16	16	<	18	16	<	35	28	24	21	22	23	23	26	22	22
	110	393	40	36	29	19	18	17	16	18	18	<	40	38	30	24	22	21	21	23	22	19	43	38	31	28	27	28	27	31	28	27
	180	648	45	41	30	23	22	23	21	21	23	17	49	43	35	28	26	27	27	29	28	25	49	44	37	33	31	30	31	34	31	29
	280	1008	46	43	35	27	25	27	26	28	27	24	53	47	41	32	30	31	33	33	32	29	54	52	43	36	34	34	37	37	36	32
	405	1458	46	41	38	34	28	28	26	27	29	23	59	48	44	39	34	34	39	38	37	33	60	55	50	42	38	38	42	42	41	37
250	60	216	23	27	<	<	<	<	<	<	<	38	28	<	<	<	<	<	<	<	<	29	28	18	<	21	24	19	18	20	17	
	170	612	41	40	25	16	<	19	<	15	19	<	45	40	29	24	23	24	21	19	23	17	45	40	32	29	29	28	26	27	23	
	280	1008	48	43	29	22	<	25	20	25	24	21	54	47	35	29	27	29	28	28	29	24	52	47	38	34	33	32	33	33	29	
	470	1692	48	43	34	28	27	29	24	26	27	22	57	50	41	36	33	33	34	32	34	29	60	53	47	42	38	36	40	39	39	34
	615	2214	48	40	43	35	28	27	21	24	30	22	57	51	46	39	37	36	38	35	37	32	63	55	50	46	41	39	44	43	43	38
315	105	378	27	27	<	<	<	<	<	<	<	38	30	15	<	20	19	<	15	17	<	36	30	23	23	24	29	23	25	25	22	
	265	954	46	36	25	20	21	22	17	21	21	17	49	40	33	27	27	28	28	27	27	22	45	40	36	34	32	33	31	32	32	28
	420	1512	53	40	30	25	25	27	22	26	26	22	54	44	39	33	31	32	32	32	32	28	52	45	42	38	36	36	35	36	36	31
	720	2592	59	46	38	31	31	32	28	32	32	28	59	49	44	37	36	36	38	37	37	32	60	51	49	43	40	41	40	41	41	37
	1025	3690	63	50	44	38	34	34	31	34	36	29	61	51	48	41	39	38	39	39	39	34	65	55	52	47	43	44	46	45	45	40
400	170	612	31	26	16	15	18	15	<	15	<	43	31	26	21	24	25	23	23	23	19	41	32	30	31	32	31	32	32	31	28	
	445	1602	44	33	28	23	24	25	24	23	24	19	50	39	38	31	30	31	34	34	32	29	48	41	41	37	36	35	37	38	36	33
	710	2556	49	38	32	28	29	31	30	29	29	25	55	45	42	34	33	33	37	35	35	31	55	48	47	41	38	38	41	40	39	35
	1250	4500	62	46	43	35	34	34	35	37	36	32	63	48	45	39	39	38	43	42	40	37	63	52	52	45	42	42	46	45	44	40
	1680	6048	70	54	46	42	40	35	37	41	41	37	71	54	49	43	42	40	45	45	44	40	69	57	54	48	44	44	48	48	47	43

< indicates values below 15

Reheat Coil Selection

1 Mean Water Pressure Drop for Sizes 125 to 400

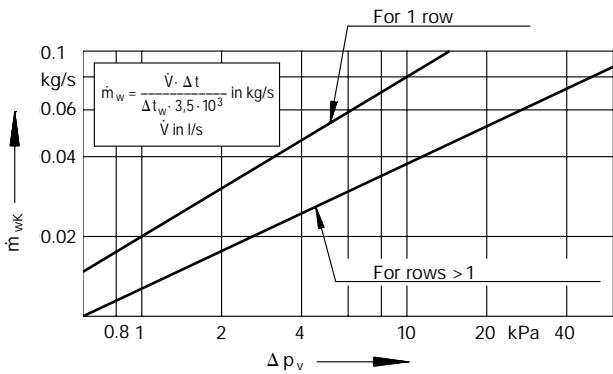

Water Pressure Drop Calculation

One, two or four row reheat coil

$$\dot{m}_{wK} = \frac{\dot{m}_w}{K} \text{ in kg/s}$$

Number of Rows

Size		125	160	200	250	315	400
K	1RR	1	1	2	2	2	4
	2RR	1	2	4	4	5	7
	4RR	1	2	4	4	5	9

2 Selection Diagram

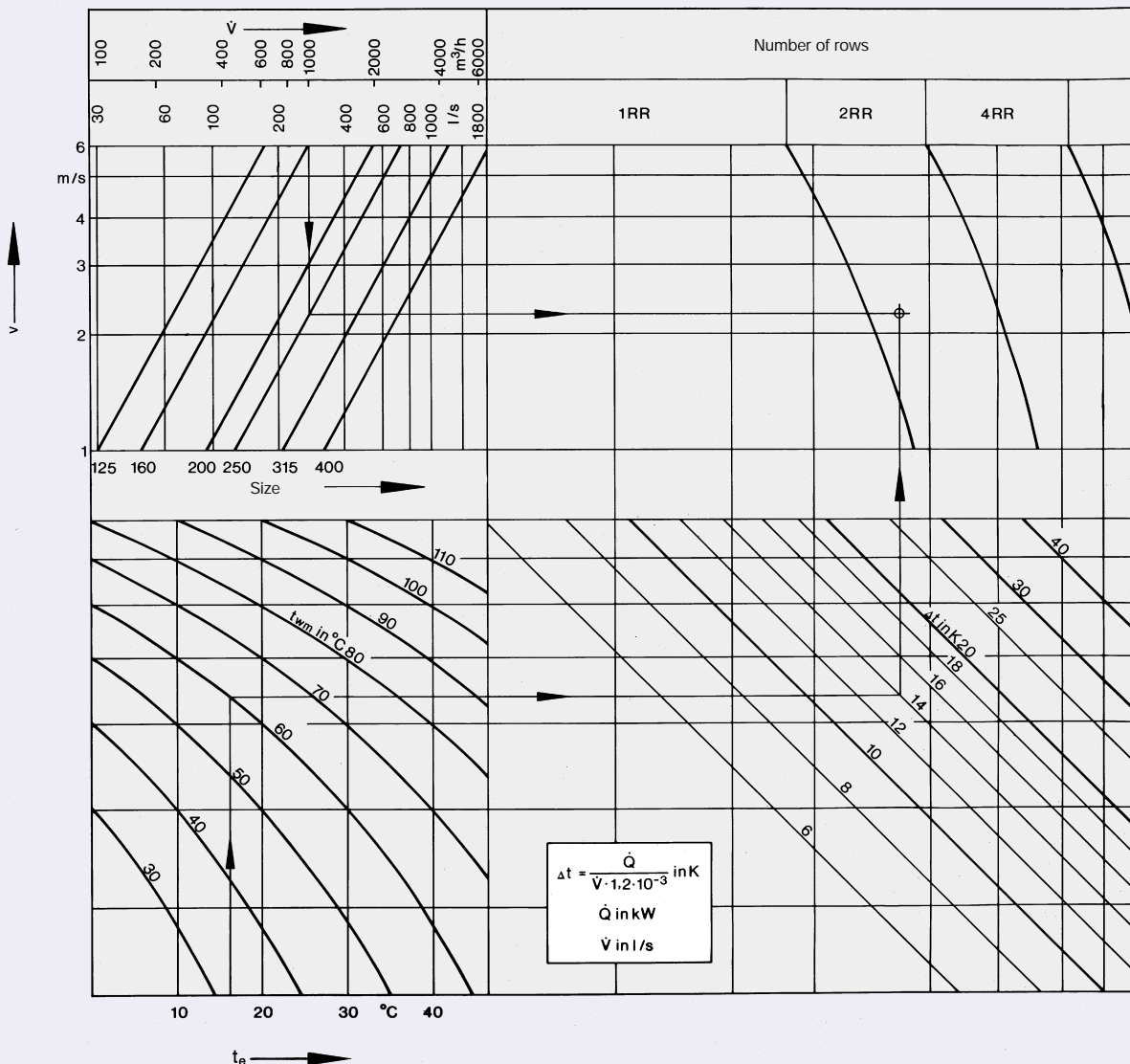

Order Details TVZ · TS

Specification Text

VAV terminal box for variable volume supply air systems, flow rate range 15 to 1680 l/s or 54 to 6048 m³/h. Comprising the casing with damper blade airtight to DIN 1946, Part 4, averaging differential pressure sensor, integral attenuator and factory installed and prewired control components. Each VAV box is aerodynamically factory tested and set to the required volume flow rate. The minimum and maximum volume flow rates can be adjusted on site by others. Baffle plates are located behind the control damper to optimise acoustic and aerodynamic performance. Casing is lined with acoustic and thermal insulation. Inlet circular spigots will fit DIN duct sizes, flange for lip seal, low pressure duct connection suitable for angle flange or slide on flange. Casing air leakage rate complies with Class 11, VDI 3803 or DIN V 24194, Part 2. Unit conforms with clean room Class 3 VDI 2803 and Class 100 to US Standard 209b. Static differential pressure range to 1500 Pa. Volume flow range approx., 10:1 depending on type of controller.

Control:

- Variable volume flow control, electronic controller for connection of control signal. Actual signal value can be read. Dynamic/static differential pressure measurement, supply voltage 24 VAC., signal voltage 2...10 VDC/0...10 VDC.

- Variable volume flow control, pneumatic controller for connection of control signal. Static differential pressure measurement P-PI/control, unit signal 0.2... 1.0 bar, normally open/normally closed, direct acting/reverse acting.
- Room temperature and variable control digital controller with integral/separate transducer. Communication by databus. Triac switching for 3 point control of actuator, communication available through room temperature sensor. Override switching, window switch; actuator; 24 VAC 3 point.

Materials: Casing in galvanised sheet steel. Mineral wool lining to attenuator and damper section with glass fibre scrim facing suitable for velocities up to approx. 20 m/s. Non-combustible to DIN 4102, building materials Class A2. Damper blade with thermoplastic seal, aluminium sensor tubing, plastic bearings.

Optionally available with:

Acoustic cladding: For reduction of case-radiated noise from casing; 40mm mineral wool and an outer casing of galvanised sheet steel.

Reheat Coil: For terminal heating of volume flow. Galvanised sheet steel casing, copper pipes and aluminium fins, reheat section connection to discharge incorporates flanges both ends.

TS Secondary Silencer: For reduction of air-regenerated noise, made of mineral wool and casing in galvanised steel, connectable to the box, suitable for connection to slide-on flange.

Order Code TVZ

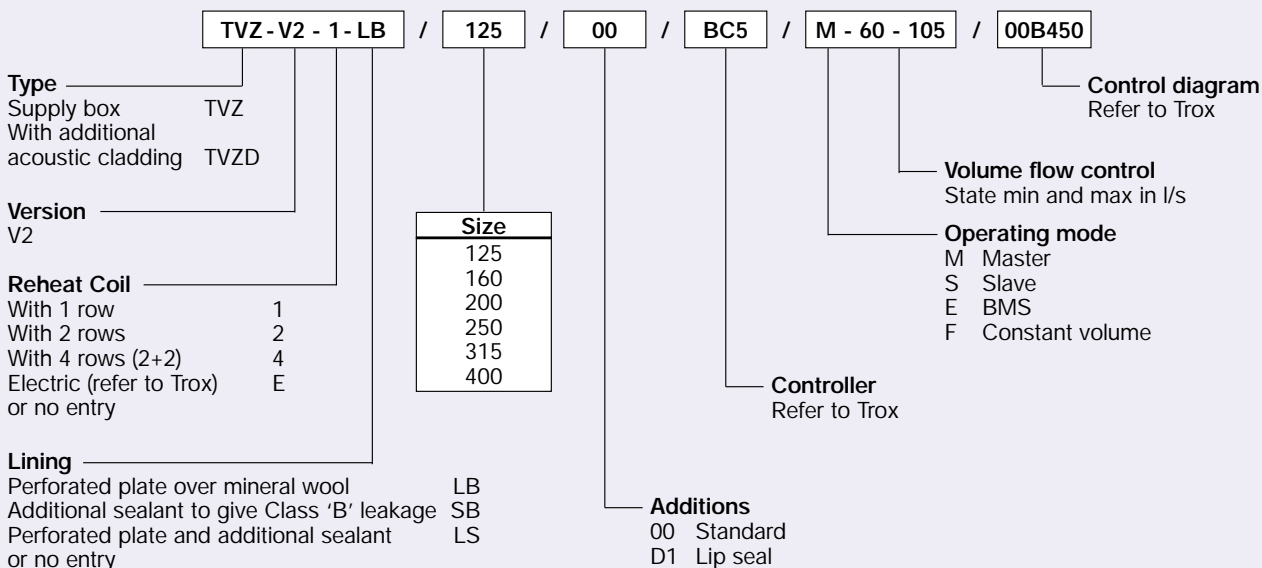

Order Details TS

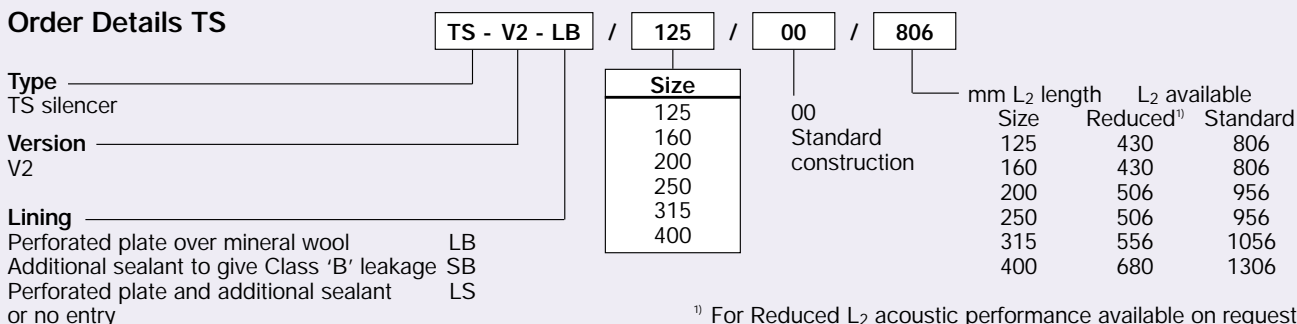

¹⁾ For Reduced L₂ acoustic performance available on request.

Order Example TVZ

Make: TROX
 Type: TVZ-V2-1-LB/125/00/BC5/M-60-105/00B450

Order Example TS

Make: TROX
 Type: TS-V2-LB/125/00/806

Order Details TVA · TS

Specification Text

VAV terminal box for variable volume extract air systems, flow rate range 15 to 1680 l/s or 54 to 6048 m³/h. Comprising the casing with damper blade airtight to DIN 1946, Part 4, averaging differential pressure sensor, integral attenuator and factory installed and pre-wired control components. Each VAV box is aerodynamically factory tested and set to the required volume flow rate. The minimum and maximum volume flow rates can be adjusted on site by others. Baffle plates are located behind the control damper to optimise acoustic and aerodynamic performance. Casing is lined with acoustic and thermal insulation. Inlet circular spigots will fit DIN duct sizes, flange for lip seal, low pressure duct connection suitable for angle flange or slide on flange. Casing air leakage rate complies with Class 11, VDI 3803 or DIN V 24194, Part 2. Unit conforms with clean room Class 3 VDI 2803 and Class 100 to US Standard 209b. Static differential pressure range to 1500 Pa. Volume flow range approx., 10:1 depending on type of controller.

Control:

- Variable volume flow control, electronic controller for connection of control signal. Actual signal value can be read. Dynamic/static differential pressure measurement, supply voltage 24 VAC., signal voltage 2...10 VDC/0...10 VDC.

- Variable volume flow control, pneumatic controller for connection of control signal. Static differential pressure measurement P-PI/control, unit signal 0.2... 1.0 bar, normally open/normally closed, direct acting/reverse acting.
- Room temperature and variable control digital controller with integral/separate transducer. Communication by databus. Triac switching for 3 point control of actuator, communication available through room temperature sensor. Override switching, window switch; actuator; 24 VAC 3 point.

Materials:

Casing in galvanised sheet steel. Mineral wool lining to attenuator and damper section with glass fibre scrim facing suitable for velocities up to approx. 20 m/s. Non-combustible to DIN 4102, building materials Class A2. Damper blade with thermoplastic seal, aluminium sensor tubing, plastic bearings.

Optionally available with:

Acoustic Cladding: For reduction of radiated noise from casing: 40mm mineral wool and an outer casing of galvanised sheet steel.
TS Secondary Silencer: For reduction of air-regenerated noise, made of mineral wool and casing in galvanised steel, connectable to the box, suitable for connection to slide-on flange.

Order Code TVA

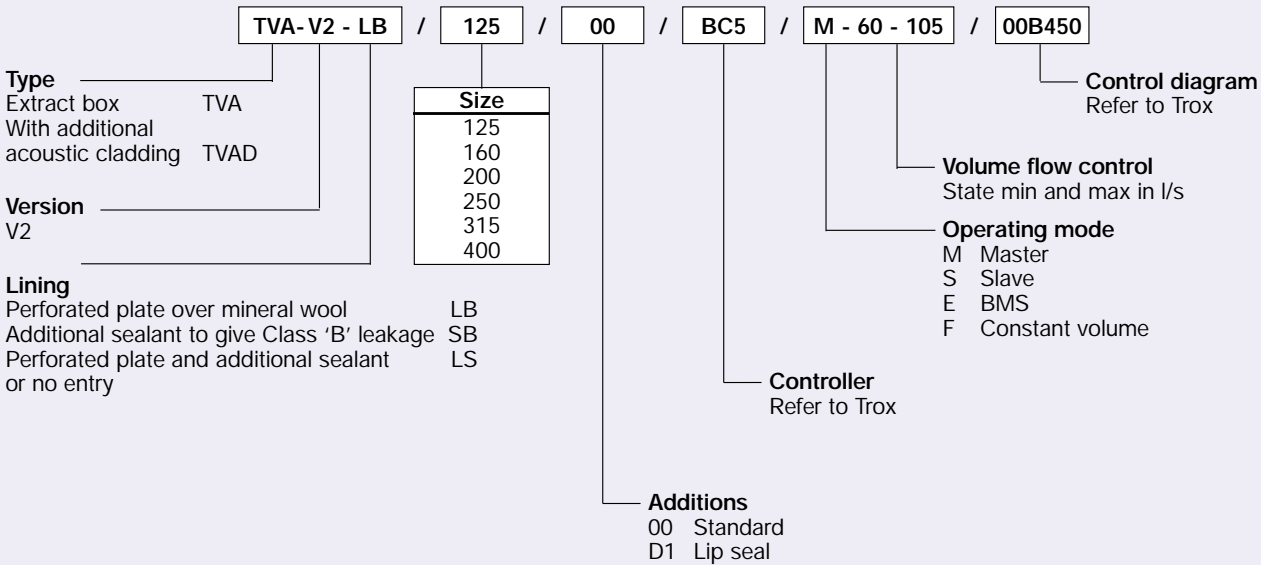

Order Details TS

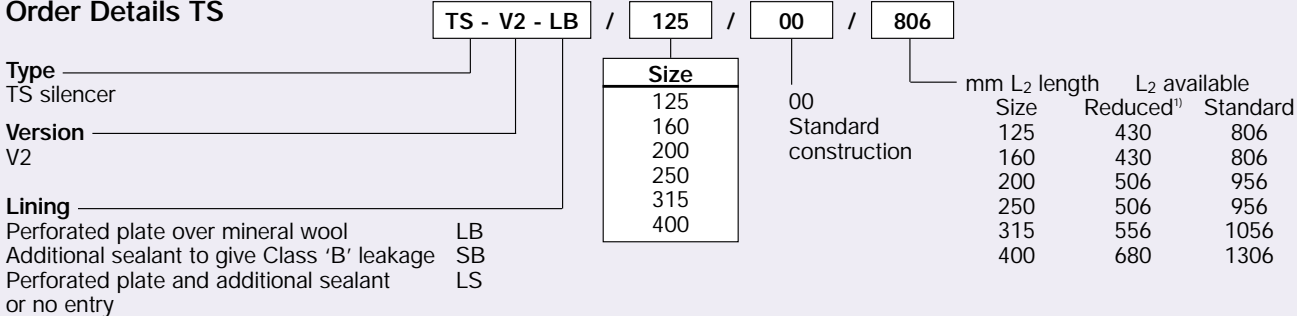

¹⁾ For Reduced L₂ acoustic performance available on request.

Order Example TVA

Make: TROX
 Type: TVA-V2-LB/125/00/BC5/M-60-105/00B450

Order Example TS

Make: TROX
 Type: TS-V2-LB/125/00/806