

VARYCONTROL VAV Controller

for variable volume systems

Type TVR



TROX[®] TECHNİK

Contents · Description

Description _____	2	Air Regenerated Noise with Circular Silencer _____	7
Construction and Dimensions _____	3	Air Regenerated Noise _____	8
Control _____	5	Case Radiated Noise _____	9
Nomenclature _____	6	Order Details _____	10
Aerodynamic Data _____	6		

VAV-Controller Type TVR



VAV-Controller Type TVRD



Trox VARYCONTROL VAV controllers Type TVR/TVRD are circular volume flow control units for variable volume supply or extract systems. Also for use as room or duct pressure controllers TVR controllers consist of a circular duct with control damper and differential pressure grid to measure the volume flow rate. The damper with plastic elastomer seal has a leakage rate in the closed position which complies with DIN 1946 Part 4. The controllers can also be supplied with acoustic cladding to reduce case radiated noise, Type TVRD.

The control components (velocity controller, transducer, actuator) are factory fitted complete with tubing and wiring.

Trox VAV controllers can be supplied with a wide range of control components, which are selected according to the project specification. Every controller is factory tested and set to the required volume flow rates.

Further information on application, selection and the control components available is contained in Product Information leaflet "VARYCONTROL VAV UNITS".

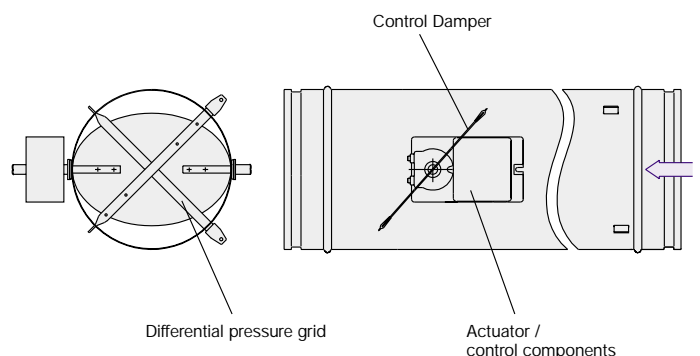

Construction · Dimensions

Design Features

Casing

- Spigot connections for circular ducts to DIN 24 145 or DIN 24 146 with groove for lip seal (lip seal can be fitted in the factory or on site by others)
- Optional flange connections to DIN 24 154, Part 1 or with rolled edge for duct clamping systems
- Leakage flow rate to Class II, VDI 3803 or DIN V 24 194, Part 2

Volume Flow Control

- Either pneumatic or electronic
- Suitable for supply or extract air
- Volume flow range depending on type of controller, approx. 10:1
- High accuracy of set volumes by use of differential pressure grid, even with extreme inlet conditions (see page 5)
- Differential pressure range 20 to 1500 Pa
- Control damper leakage to DIN 1946, Part 4

- control damper can be fully closed (control switch by others)
- Can be mounted in any orientation (where membrane pressure sensors are used, install in position shown on label)
- Volume flow preset in factory and each VAV controller tested with air flow
- Volume flow measurement and adjustment of set points possible on site
- The control damper mechanism of the VAV controller is maintenance free
- Operating temperature range 10 to 50 °C

Pressure Control

- Duct or room pressure control
- Positive/negative pressures
- nominal pressure difference factory-set, subsequent site adjustment possible (by others)
- Adjustment range dependent on the controller

TVR, Basic construction

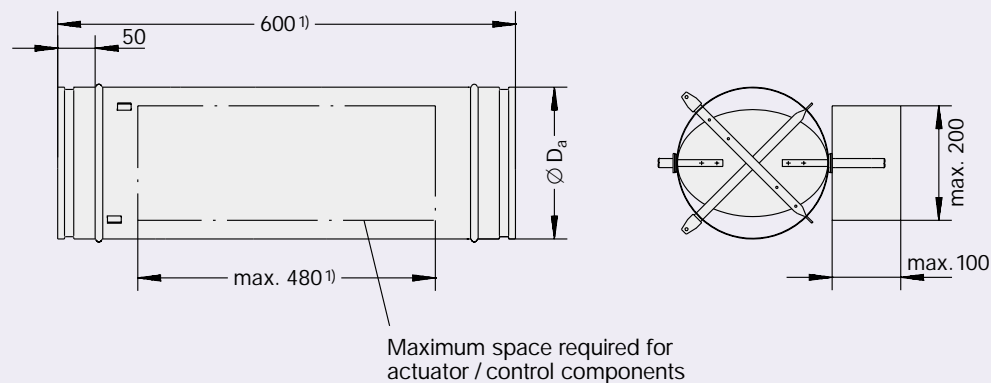

TVRD, Basic construction

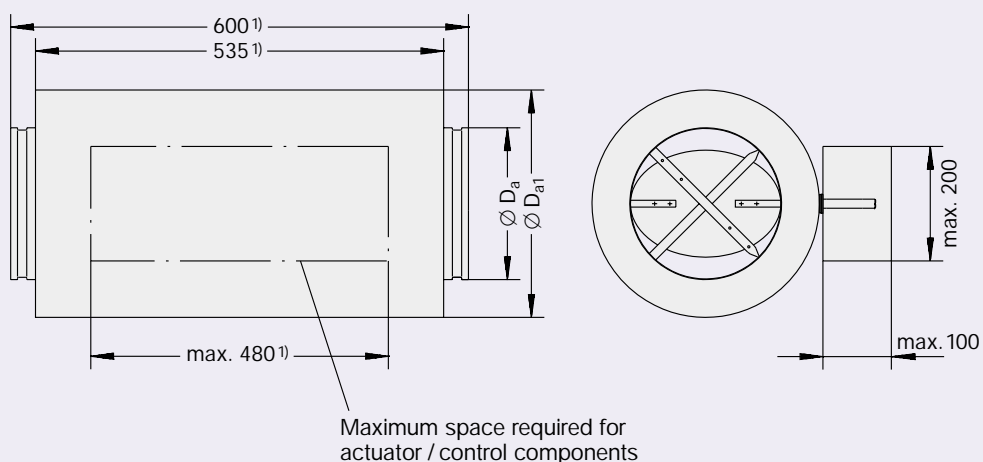

Allow adequate access to control components.

Acoustic Cladding

- To reduce case-radiated noise
- External cover in galvanised sheet steel
- Acoustic lining

Materials

- Casing and attachments in galvanised sheet steel
- Plastic plain bearings
- Control damper in galvanised sheet steel with thermoplastic elastomer seal
- Aluminium sensor tubes

Flange construction

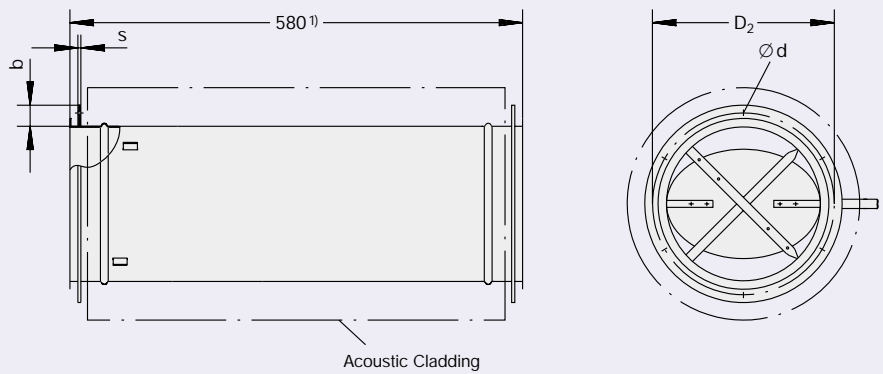

Rolled edge construction

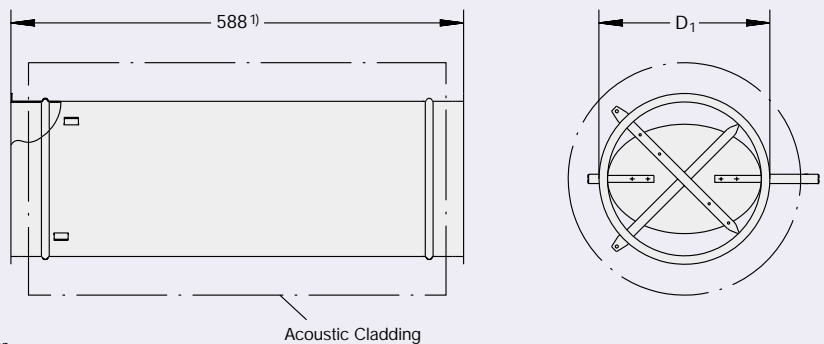

1) Minus 200 for construction with compact controller sizes 100 to 200.
Plus 200 for construction with LABCONTROL.

Table 1: Dimensions in mm

Size	Ø D _a	Ø D _{a1}	Ø D ₁	Ø D ₂	b	s	Ø d	n ²⁾
100	99	198	111	132	25	3	9.5	4
125	124	223	136	157	25	3	9.5	4
160	159	258	171	192	25	4	9.5	6
200	199	298	211	233	25	4	9.5	6
250	249	348	261	283	25	4	9.5	6
315	314	413	326	352	30	4	9.5	8
400	399	498	411	438	30	4	9.5	8

2) n = number of holes in flanges

Table 2: Weights in kg

Size	TVR	TVRD	Additional weight with flanges
100	3.3	7.2	0.6
125	3.6	8.5	0.6
160	4.2	11.0	1.1
200	5.1	12.9	1.4
250	6.1	15.9	1.7
315	7.2	18.1	3.1
400	9.4	22.6	3.9

Depending on the application, there are three types of controls; volume flow control, duct pressure and room pressure control.

Volume Flow Control

The pressure differential Δp_w measured at the differential pressure grid is transmitted to the electronic or pneumatic controller as a reference signal via the transducer. The controller compares the actual value with the set value. If there is a discrepancy, the actuator adjusts the control damper accordingly, thus keeping the volume flow constant within close tolerances over the entire differential pressure range.

Pressure Control

TVR controllers are suitable for use as duct or room pressure controllers. Here the differential pressure either between the duct and the surrounding area or between two rooms is measured and transmitted to the controller as a reference signal

- ① Differential pressure grid
- ② Control damper
- ③ Transducer
- ④ Actuator
- ⑤ Volume flow rate controller
- ⑥ Room temperature controller (supplied by others)
- Wiring or piping by others

Volume Flow Control

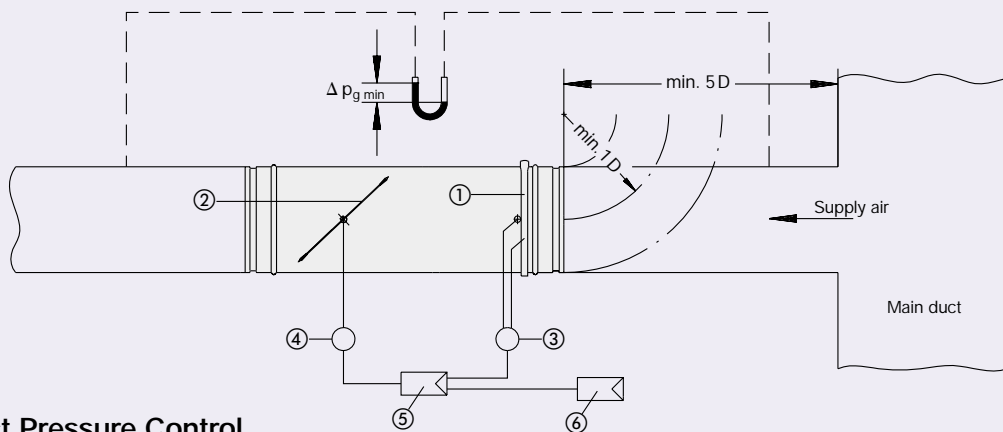

Duct Pressure Control

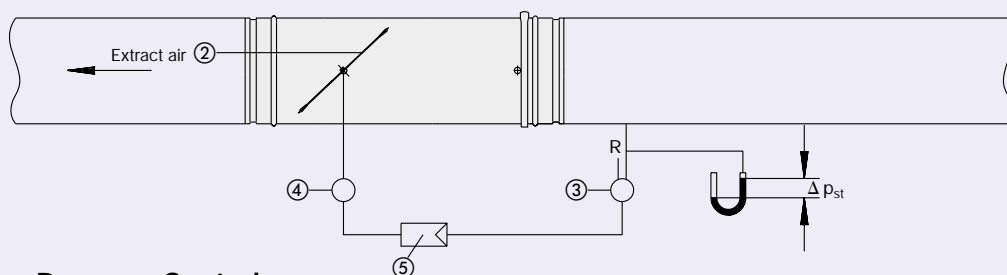

Room Pressure Control

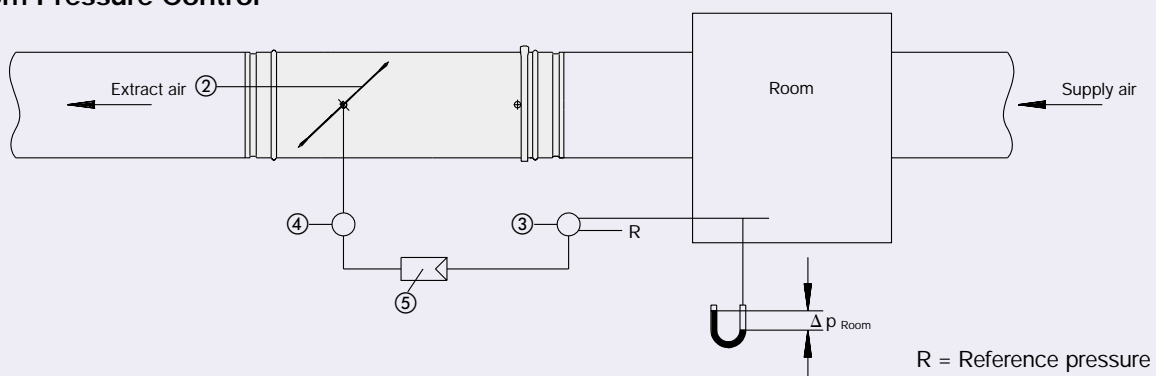

Nomenclature · Aerodynamic Data

Nomenclature

f_m	in Hz: Octave band centry frequency
L_W	in dB: Air generated sound power level measured in reverberation chamber (re 1pW)
L_{W1}	in dB: Case radiated sound power level measured in reverberation chamber (re 1pW)
L	in dB(A): Air generated A-weight sound pressure level including 8 dB room attenuation
L_1	in dB(A): Case radiated A-weighted sound pressure level including 8 dB room attenuation
NC	: Noise criteria including 8 dB room attenuation
Δp_{st}	in Pa: Static pressure differential for duct pressure control
Δp_g	in Pa: Total pressure differential

$\Delta p_{g \min}$	in Pa: Minimum total pressure differential
ΔV	in \pm %: Deviation of set volume flows
ΔL_W	in dB: Correction values for regenerated noise back into upstream direction
$\Delta L_{W1 \text{ to } 3}$	in dB: Correction values for case radiated noise
$\Delta L_{1 \text{ to } 3}$	in dB: Correction values for A-weighted case radiated noise
B	in m: Length of Trox circular attenuator type CA

To calculate the sound power level spectrum in the duct, the figures in the tables should be added to the corresponding end reflection values (see VDI 2081).

Table 3: Volume flow range and minimum pressure differential for controllers with diaphragm pressure transducer

Size	V		$\Delta p_{g \min}$ in Pa	ΔV ¹⁾ in \pm %
	in l/s	in m ³ /h		
100	20	72	20	9
	30	108	20	8
	60	216	30	7
	95	342	70	5
125	30	108	20	9
	60	216	20	7
	105	378	55	6
	150	540	90	5
160	50	180	20	9
	80	288	20	8
	145	522	35	7
	250	900	70	5
200	80	288	20	9
	180	648	20	7
	310	1116	35	5
	405	1458	65	5
250	120	432	20	9
	270	972	20	7
	470	1692	25	5
	615	2214	45	5
315	210	756	20	9
	425	1530	20	7
	740	2664	20	6
	1025	3690	30	5
400	340	1224	20	9
	715	2574	20	7
	1250	4500	25	6
	1680	6048	25	5

1) Typical values

Table 4: Volume flow range and minimum pressure differential for controllers with dynamic pressure transducer

Size	V		$\Delta p_{g \min}$ in Pa	ΔV ¹⁾ in \pm %
	in l/s	in m ³ /h		
100	10	36	20	20
	30	108	20	8
	60	216	30	7
	95	342	70	5
125	15	54	20	20
	60	216	20	7
	105	378	55	6
	150	540	90	5
160	25	90	20	20
	80	288	20	8
	145	522	35	7
	250	900	70	5
200	40	144	20	20
	180	648	20	7
	310	1116	35	5
	405	1458	65	5
250	60	216	20	20
	270	972	20	7
	470	1692	25	5
	615	2214	45	5
315	105	378	20	20
	425	1530	20	7
	740	2664	20	6
	1025	3690	30	5
400	170	612	20	20
	715	2574	20	7
	1250	4500	25	6
	1680	6048	25	5

Air Regenerated Noise

with Circular Silencer Type CA

Example

Given: Size 125
 $\dot{V} = 60 \text{ l/s or } 216 \text{ m}^3/\text{h}$
 $\Delta p_g = 250 \text{ Pa}$
 Permissible sound pressure level in room
 45 dB(A) with 4 dB room attenuation

Required: Air regenerated noise in the room

Calculation

f_m	63	125	250	500	1k	2k	4k	8k
L_w	43	51	53	53	55	50	43	39
Noise reduction								
Duct attenuation ¹⁾	0	0	0	0	1	2	3	4
Room Attenuation ¹⁾	4	4	4	4	4	4	4	4
	39	47	49	49	50	44	36	31
A-weighting	-26	-16	-9	-3	0	1	1	-1
Corrected level	13	31	40	46	50	45	37	30

¹⁾ see VDI 2081 for example

Result: L approx. 53 dB(A) by logarithmic addition.
 Without Attenuator specification is not met.
 Attenuator of 500 mm length is required.
 Repeat the calculation process and the result is L approx. 38 dB(A), specification is met.

Table 5: Regenerated noise on discharge side

Size	\dot{V}		B	$\Delta p_g = 100 \text{ Pa}$														$\Delta p_g = 250 \text{ Pa}$														$\Delta p_g = 500 \text{ Pa}$														$\Delta p_g = 1000 \text{ Pa}$													
				$L_w \text{ in dB}$														$L_w \text{ in dB}$														$L_w \text{ in dB}$														$L_w \text{ in dB}$													
				$f_m \text{ in Hz}$														$f_m \text{ in Hz}$														$f_m \text{ in Hz}$														$f_m \text{ in Hz}$													
				63	125	250	500	1000	2000	4000	8000	L in dB(A)	NC	63	125	250	500	1000	2000	4000	8000	L in dB(A)	NC	63	125	250	500	1000	2000	4000	8000	L in dB(A)	NC	63	125	250	500	1000	2000	4000	8000	L in dB(A)	NC																
100	10	36	0,5	15	<	18	<	<	<	<	<	<	<	<	<	<	<	<	<	23	22	26	22	<	19	16	17	<	28	27	31	27	20	<	24	21	22	19	33	32	36	32	25	19	29	26	27	24											
	30	108	0,5	28	31	32	26	15	<	<	<	<	<	19	<	<	<	<	<	36	39	40	34	23	<	21	22	27	21	41	44	45	39	28	18	26	27	32	26	46	49	50	44	33	23	31	32	37	31										
	60	216	0,5	36	44	46	37	23	<	19	22	32	29	44	52	54	45	31	20	27	30	40	37	49	57	59	50	36	25	32	35	45	42	54	62	64	55	41	30	37	40	50	47	59	56	54													
	95	342	0,5	40	52	52	44	31	20	27	30	38	36	48	60	60	52	39	28	35	38	46	44	53	65	65	57	44	33	40	43	51	49	58	70	70	62	49	38	45	48	56	54	54															
125	15	54	0,5	20	16	21	28	24	<	17	<	<	20	15	28	24	29	36	32	22	25	21	28	23	33	29	34	41	37	27	30	26	33	28	38	34	39	46	42	32	35	31	38	33															
	60	216	0,5	32	39	38	33	26	19	23	21	27	21	40	47	46	41	34	27	31	29	35	29	45	52	51	46	39	32	36	34	40	34	50	57	56	51	44	37	41	39	45	39																
	105	378	0,5	39	47	46	38	27	20	26	26	32	29	47	55	54	46	35	28	34	34	40	37	52	60	59	51	40	33	39	39	45	42	57	65	64	56	45	38	44	44	50	47																
	105	378	1,0	38	44	41	27	<	<	<	16	26	23	46	52	49	35	18	<	17	24	34	31	51	57	54	40	23	<	22	29	39	36	56	62	59	45	28	19	27	34	44	41																
160	150	540	0,5	43	51	50	42	30	22	29	28	36	34	51	59	58	50	38	30	37	36	44	42	56	64	63	55	43	35	42	41	49	47	61	69	68	60	48	40	47	46	54	52																
	150	540	1,0	42	48	45	31	<	<	<	18	30	28	50	56	53	39	21	<	20	26	38	36	55	61	58	44	26	16	25	31	43	41	60	66	63	49	31	21	30	36	48	46																
	25	90	0,5	22	17	21	25	22	22	23	18	21	17	30	25	29	33	30	30	31	26	29	25	35	30	34	38	35	35	36	31	34	30	40	35	39	43	40	40	41	36	39	35																
	80	288	0,5	35	35	37	34	27	24	28	25	28	22	43	43	45	42	35	32	36	33	36	30	48	48	50	47	40	37	41	38	41	35	53	53	55	52	45	42	46	43	46	40																
200	145	522	0,5	45	45	47	40	30	26	31	30	34	31	53	53	55	48	38	34	39	38	42	39	58	58	60	53	43	39	44	43	47	44	63	63	65	58	48	44	49	48	52	49																
	145	522	1,0	44	43	44	31	<	<	21	23	29	27	52	51	52	39	22	21	29	31	37	35	57	56	57	44	27	26	34	36	42	40	62	61	62	49	32	31	39	41	47	45																
	250	900	0,5	51	55	53	47	34	30	35	34	40	38	59	63	61	55	42	38	43	42	48	46	64	68	66	60	47	43	48	47	53	51	69	73	71	65	52	48	53	52	58	56																
	250	900	1,0	50	53	50	38	18	17	25	27	36	34	58	61	58	46	26	25	33	35	44	42	63	66	63	51	31	30	38	40	49	47	68	71	68	56	36	35	43	45	54	53																
250	40	144	0,5	25	18	22	26	24	27	29	24	26	23	33	26	30	34	32	35	37	32	34	31	38	31	35	39	37	40	42	37	39	36	43	36	40	42	45	47	42	44	41																	
	40	144	1,0	24	16	19	19	<	18	22	19	18	16	32	24	27	27	17	26	30	27	26	24	37	29	32	32	22	31	35	32	31	29	42	34	37	37	27	36	40	37	36	34																
	180	648	1,0	48	49	43	33	16	20	27	27	30	27	56	57	51	41	24	28	35	35	38	35	61	62	56	46	29	33	40	40	43	40	66	67	61	51	34	38	45	45	48	45																
	405	1458	1,0	56	55	52	43	21	26	32	32	39	38	64	63	60	51	29	34	40	40	47	46	69	68	65	56	34	39	45	45	52	51	74	73	70	61	39	44	50	57	56																	
315	60	216	1,0	29	24	26	23	<	24	27	23	23	21	37	32	34	31	20	32	35	31	31	29	42	37	39	36	25	37	40	36	36	34	47	42	44	41	30	42	45	41	41	39																
	60	216	1,5	28	23	24	19	<	18	22	20	18	16	36	31	32	27	<	26	30	28	26	24	41	36	37	32	<	31	35	33	31	29	46	41	42	37	19	36	40	38	36	34																
	270	972	1,0	49	50	45	35	20	26	32	32	33	28	57	58	53	43	28	34	40	40	41	36	62	63	58	48	33	39	45	45	46	41	67	68	63	53	38	44	50	50	51	46																
	270	972	1,5	49	49	43	31	<	20	27	29	30	27	57	57	51	39	17	28	35	37	38	35	62	62	56	44	22	33	40	42	43	40	67	67	61	49	27	38	45	47	48	45																
400	470	1692	1,5	55	55	51	38	<	23	30	30	37	35	63	63	59	46	20	31	38	38	45	43	68	68	64	51	25	36	43	43	50	48	73	73	69	56	30	41	48	48	55	53																
	615	2214	1,5	58	57	53	41	<	25	32	32	40	39	66	65	61	49	22	33	40	40	48	47	71	70	66	54	27	38	45	45	53	52	76	75	71	59	32	43	50	50	58	57																
	105	378	1,0	34	33	32	27	17	27	33	32	29	27	42	41	40	35	25	35	41	40	37	35	47	46	45	40	30	40	46	45	42	40	52	51	50	45	35	45	51	50	47	45																
	425	1530	1,0	51	51	44	35	22	30	34	34	34	29	59	59	52	43	30	38	42	42	42	37	64	64	57	48	35	43	47	47	47	42	69	69	62	53	40	48	52	52	52	47																
400	425	1530	1,5	50	50	42	30	<	26	30	31	31	28	58	58	50	38	20	34	38	39	39	63	63	55	43	25	39	43	44	44	41	68	68	60	48	30	44	48	49	49	46																	
	740	2664	1,5	57	57	49	36	15																																																			

Air Regenerated Noise

Example

Data Given: TVR Size 125

$\dot{V} = 60$ to 105 l/s or 216 to 378 m³/h

$\Delta p_g = 250$ Pa

Specified sound pressure level in room
55 dB(A) with 8 dB room attenuation

Required: Air regenerated noise in room in dB(A) at
 $\dot{V} = 105$ l/s or 378 m³/h

Result: $L = 53$ dB(A), specification is met.

Correction values for regenerated noise back into upstream duct

f_m in Hz	63	125	250	500	1000	2000	4000	8000
ΔL_w in dB	5	3	3	2	-1	1	0	1

Table 6: Regenerated noise on discharge side

Size	\dot{V}		$\Delta p_g = 100$ Pa														$\Delta p_g = 250$ Pa														$\Delta p_g = 500$ Pa														$\Delta p_g = 1000$ Pa													
			L_w in dB														L_w in dB														L_w in dB														L_w in dB													
			f_m in Hz														f_m in Hz														f_m in Hz														f_m in Hz													
			63	125	250	500	1000	2000	4000	8000	L in dB(A)	NC	63	125	250	500	1000	2000	4000	8000	L in dB(A)	NC	63	125	250	500	1000	2000	4000	8000	L in dB(A)	NC	63	125	250	500	1000	2000	4000	8000	L in dB(A)	NC																
100	10	36	32	32	31	28	22	<	<	<	20	<	26	27	34	36	38	39	37	29	36	32	31	32	39	41	43	44	42	34	41	37	37	36	41	42	42	44	47	47	43	41																
	30	108	36	46	43	42	36	30	25	21	34	28	39	44	48	48	46	43	39	35	43	37	44	49	53	53	51	48	44	40	48	42	45	49	55	56	54	51	50	49	51	44																
	60	216	40	53	52	52	49	45	37	32	45	40	47	57	62	59	54	50	45	43	52	48	52	62	67	64	59	55	50	48	57	53	54	61	69	69	63	61	56	55	62	58																
	95	342	47	52	57	60	59	55	49	42	55	50	51	66	68	66	63	59	54	52	60	55	56	71	73	71	68	64	59	57	65	60	62	70	76	76	72	68	63	60	69	66																
125	15	54	31	33	38	42	34	22	<	17	32	28	31	28	36	48	53	45	37	31	46	44	36	33	41	53	58	50	42	36	51	49	45	34	43	52	57	55	49	43	52	47																
	60	216	44	52	49	47	41	33	27	30	39	34	43	51	53	53	55	50	43	39	50	46	48	56	58	58	60	55	48	44	55	51	50	53	58	61	64	66	66	59	53	62	58															
	105	378	49	54	56	54	48	41	36	35	46	42	50	59	61	58	56	51	46	44	53	47	55	64	66	63	61	56	51	49	58	52	55	62	66	66	66	67	61	56	64	59																
	150	540	57	57	60	60	56	51	48	45	53	48	54	63	65	62	59	53	46	46	56	51	59	68	70	67	64	58	51	51	61	56	58	65	70	69	67	67	62	57	65	59																
160	25	90	35	35	37	40	33	24	18	22	31	26	32	28	35	43	48	47	39	34	44	39	37	33	40	48	53	52	44	39	49	44	45	36	43	51	55	58	53	48	54	51																
	80	288	47	50	47	46	40	34	30	30	38	32	45	46	51	52	53	49	44	41	48	43	50	51	56	57	58	54	49	46	53	48	52	50	56	60	62	64	58	53	60	57																
	145	522	53	56	54	52	46	41	38	36	45	40	55	56	61	58	56	51	47	46	53	47	60	61	66	63	61	56	52	51	58	52	59	61	66	67	65	66	61	57	63	59																
	250	900	60	59	61	62	58	52	50	47	55	50	61	66	67	65	60	55	51	50	58	54	66	71	72	70	65	60	56	55	63	59	69	72	75	73	69	68	64	60	67	62																
200	40	144	42	37	37	39	34	29	25	25	32	25	34	28	35	43	48	48	42	38	45	40	39	33	40	48	53	53	47	43	50	45	47	36	44	51	55	62	55	50	57	54																
	180	648	53	56	52	48	41	38	35	34	42	35	58	61	59	57	55	50	47	46	52	46	63	66	64	62	60	55	52	51	57	51	63	63	65	65	64	65	61	59	62	58																
	310	1116	58	57	58	57	51	44	41	40	49	44	63	67	65	63	57	54	51	51	56	52	68	72	70	68	62	59	56	56	61	57	72	74	75	72	69	68	64	63	67	61																
	405	1458	62	61	62	65	59	54	52	48	57	54	67	67	69	68	61	56	52	51	60	57	72	72	74	73	66	61	57	56	65	62	73	75	78	76	71	69	65	64	70	66																
250	60	216	40	41	40	39	34	31	27	27	33	26	39	35	40	45	48	49	43	40	46	41	44	40	45	50	53	54	48	45	51	46	49	41	48	53	57	62	56	52	57	54																
	270	972	52	52	51	50	42	38	33	33	42	37	59	61	59	57	56	51	48	49	52	47	64	66	64	62	61	56	53	54	57	52	67	68	67	67	66	66	62	61	64	59																
	470	1692	59	57	56	56	49	44	40	38	48	44	65	67	67	64	59	54	51	50	57	53	70	72	72	69	64	59	56	55	62	58	72	73	74	75	70	68	64	63	68	64																
	615	2214	63	60	64	66	56	52	50	46	57	55	69	70	70	68	62	57	53	52	61	57	74	75	75	73	67	62	58	57	66	62	77	77	79	76	72	70	66	65	70	66																
315	105	378	38	43	41	39	34	31	29	28	33	25	43	43	45	47	50	48	46	46	47	41	48	48	50	52	55	53	51	51	52	46	51	47	54	55	59	61	60	58	58	54																
	425	1530	52	55	50	49	43	38	31	29	42	36	60	61	57	55	55	51	47	48	51	46	65	66	62	60	60	56	52	53	56	51	68	68	67	65	66	67	61	61	64	59																
	740	2664	59	57	56	55	47	43	38	33	47	43	67	68	64	61	58	55	51	50	56	50	72	73	69	66	63	60	56	55	61	55	76	77	74	71	69	69	64	63	68	61																
	1025	3690	64	61	65	67	56	52	48	44	58	56	71	71	70	67	62	58	54	53	61	56	76	76	75	72	67	63	59	58	66	61	80	80	80	76	73	71	67	66	71	66																
400	170	612	37	44	43	40	34	32	30	28	34	26	44	45	45	46	49	46	44	44	45	40	49	50	50	51	54	51	49	49	50	45	53	50	54	55	59	60	57	56	57	52																
	715	2574	53	54	53	52	46	40	34	30	44	39	62	62	59	57	54	52	48	47	52	45	67	67	64	62	59	57	53	52	57	50	71	71	69	66	65	65	60	60	63	58																
	1250	4500	60	58	61	62	53	46	42	35	53	50	68	68	67	64	59	56	51	50	58	53	73	73	72	69	64	61	56	55	63	58	77	77	76	73	70	69	64	63	68	63																
	1680	6048	66	61	67	68	56	51	47	42	58	57	72	71	72	69	63	59	55	53	62	58	77	76	77	74	68	64	60	58	67	63	81	82	82	78	74	72	68	67	73	68																

< indicates values less than 15

Case Radiated Noise

Example

Data Given: TVR size 160
 $\dot{V} = 25$ to 80 l/s or 90 to 288 m³/h
 $\Delta p_g = 500$ Pa
 Permissible sound power level in room 30 dB(A) with 4 dB/Oct. room attenuation and 4 dB/Oct. ceiling sound reduction. VAV controller installed as shown in Fig. 1

Required: Radiated noise in the room at $\dot{V} = 80$ l/s or 288 m³/h

Calculation

f_m	63	125	250	500	1000	2000	4000	8000
L_w ¹⁾	50	51	56	57	58	54	49	46
ΔL_1	-12	-17	-17	-18	-18	-16	-14	-12
Ceiling sound reduction	4	4	4	4	4	4	4	4
Room attenuation	4	4	4	4	4	4	4	4
A-weighting *	30	26	31	31	32	30	27	26
Corrected level	-26	-16	-9	-3	0	+1	+1	-1
	4	10	22	28	32	31	28	25

* See VDI 2081 for example

Result: L_1 approx. 37 dB(A) by logarithmic addition.
 Specification is not met. Acoustic cladding and site applied duct acoustic lagging required as Fig. 2. Repeat the calculation using ΔL_{W2} and the result is, L_1 approx. 26 dB(A), specification is met.

1) See page 8 for values

Table 7

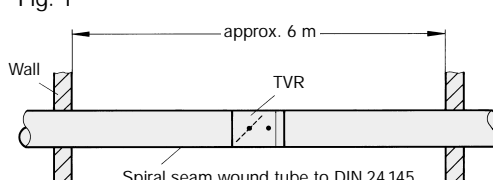
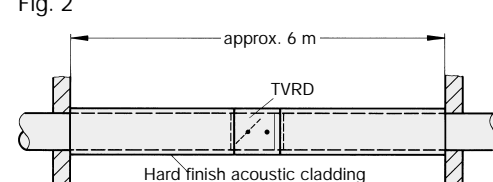
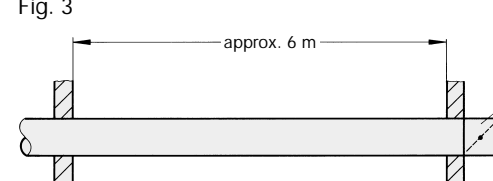
$L_{w1} = L_w - \Delta L_{W1 \text{ to } 3}$ $L_1 = L - \Delta L_{1 \text{ to } 3}$	$\Delta L_{W1 \text{ to } 3}$	Size	$\Delta L_{W1 \text{ to } 3}$ in dB							$\Delta L_{1 \text{ to } 3}$ in dB	
			f_m in Hz								
			63	125	250	500	1000	2000	4000		8000
Fig. 1  Spiral seam wound tube to DIN 24 145	ΔL_{W1}	100	9	14	17	16	17	10	11	9	14
		125	10	15	17	17	17	12	12	10	15
		160	12	17	17	18	18	16	14	12	17
		200	13	18	18	20	20	18	16	13	19
		250	11	16	16	17	16	14	12	11	15
		315	10	15	16	16	15	13	11	10	14
		400	10	14	16	16	15	12	10	10	14
Fig. 2  Hard finish acoustic cladding supplied by others	ΔL_{W2}	100	11	12	16	21	32	32	37	31	>25
		125	12	15	16	23	32	33	37	32	
		160	14	20	17	25	33	38	40	34	
		200	15	21	21	31	38	44	43	35	
		250	13	19	19	28	35	42	36	31	
		315	12	18	20	28	34	41	35	29	
		400	12	18	20	28	35	39	33	29	
Fig. 3 	ΔL_{W3}	100	9	11	18	19	15	9	9	9	14
		125	10	12	19	19	15	10	10	10	15
		160	12	14	19	20	16	13	12	12	16
		200	13	15	20	21	18	15	14	13	18
		250	11	13	18	19	14	11	11	11	15
		315	10	12	18	18	13	11	10	10	14
		400	10	11	18	18	13	10	10	10	14

Order Details

Specification Text

VAV circular controller for variable volume supply or extract systems. Consists of casing with damper blade which when closed complies with the air leakage requirements of DIN 1946, Part 4, includes integral averaging differential pressure grid and factory pre-wired control components. Site measurement and adjustment of factory-set minimum and maximum volume flow rates can be made.

Controls:

- Variable volume flow rate, electronic controller with dial setpoint and feedback signal relating to actual value, dynamic/static pressure differential measurement, supply voltage 24 VAC, signal voltage 2..10 VDC/0..10 VDC
- Variable volume flow rate, pneumatic controller with dial setpoint, differential pressure control, P/PI characteristics, control signal 0.2 to 1.0 bar, normally open, normally closed, direct or indirect acting.
- Room temperature and variable volume flow rate controller, with digital control, incorporating integral/

separate transmitter, communication via databus, Triac output for 3 point control, reversible actuator, room pressure control: slave operation, window switch; reversible actuator: 24 VAC (3 point action).

Casing air flow leakage according to Class II, VDI 3803 or DIN 24 194. Pressure difference range 20 to 1500 Pa, volume flow range, depending on controls used, up to 10:1.

Material:

Casing and attachments in galvanised sheet steel, control damper in galvanised sheet steel with thermoplastic elastomer seal, aluminium sensor tubes, plastic bearings.

Also available:

Acoustic cladding, consisting of 40 mm mineral wool and external cover of 1 mm galvanised sheet steel to reduce case radiated noise.

Order Code see price list

TVR - 2K - BK / 160 / 00 / B13 / E 2 - 25 - 250 l/s

<p>Type VAV controller TVR With acoustic cladding TVRD</p> <p>Material 2 pack paint (not for -FL) -2K Stainless steel -A2</p> <p>Construction Flange -FL Rolled edge -BK <small>(Standard design without flange or rolled edge, no entry)</small></p> <p>Options None (basic construction) 00 Matching flange (both ends) G2 Lip seal (both ends) D2</p>	<table border="1" style="margin: auto;"> <tr><td>100</td></tr> <tr><td>125</td></tr> <tr><td>160</td></tr> <tr><td>200</td></tr> <tr><td>250</td></tr> <tr><td>315</td></tr> <tr><td>400</td></tr> <tr><td style="text-align: center;">Size</td></tr> </table>	100	125	160	200	250	315	400	Size	<p>Volume flow values (V) State volume flow range and units</p> <p>Pressure control (D) State supply or extract duct application or positive/negative room pressure Pressure in Pa</p> <p>Control mode M. Master S. Slave E. Single F. Constant value U. Switched constant values</p> <p>Control components Manufacturer Controller/Transducer Actuator</p>	
100											
125											
160											
200											
250											
315											
400											
Size											

Order Example
 Make: TROX
 Type: TVR - 2K - BK / 160 / 00 / B13 / E 2 - 25-250 l/s