

Volume Flow Rate Controller

for constant volume systems
Type R

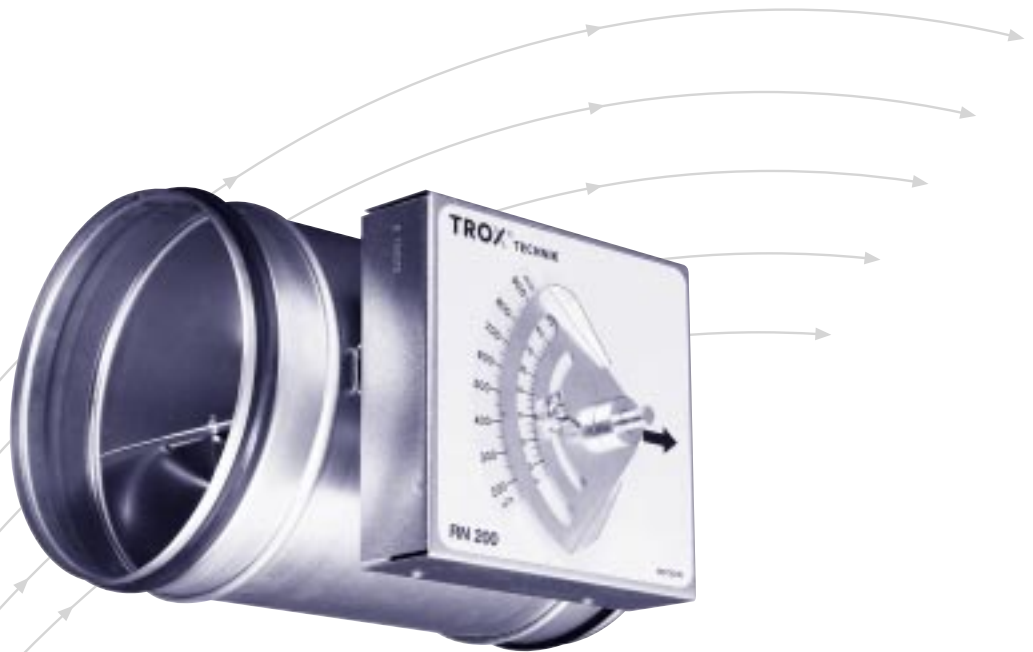

TROX[®] TECHNİK

Gebrüder Trox GmbH

Heinrich-Trox-Platz
D-47504 Neukirchen-Vluyn

Telephone +49 (0) 28 45/2 02-0
Telefax +49 (0) 28 45/2 02-2 65
www.troxtechnik.com
e-mail trox@trox.de

Contents · Description

Description _____	2	Air-Regenerated Noise _____	7
Application _____	3	Air-Regenerated Noise, Quick Selection _____	8
Design Variants and Dimensions – RNS, RN _____	4	Air-Regenerated Noise without Circular Attenuator _____	9
Design Variants and Dimensions – CA, CF and RS _____	6	Case-Radiated Noise _____	10
Nomenclature _____	7	Order Details _____	11

**Volume Flow Rate Controller
Type RNS, NW 80... 125**



**Volume Flow Rate Controller
Type RN, NW 80... 400**

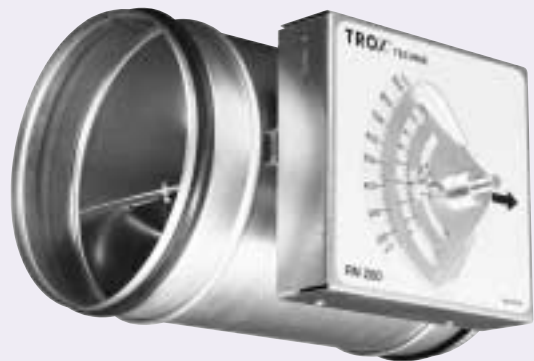

Trox volume flow rate controllers Type R are mechanical system powered controllers for constant volume systems. The volume flow rate controllers do not require an external power supply. A free moving control blade is positioned by aerodynamic forces so that a preset volume flow can be held constant over the entire differential pressure range.

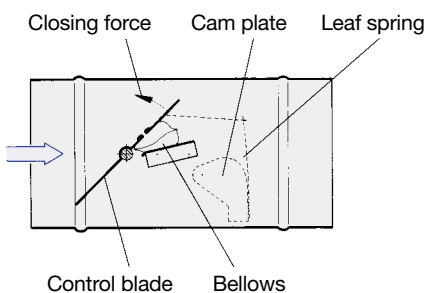

The aerodynamic closing forces on the control blade generate a closing torque. An inflatable control bellows amplifies this force and acts as an oscillation damper. A leaf spring acts against this closing torque through a cam plate. The cam plate is calibrated so that as the pressure difference changes, the angle of the control blade is set so that the volume flow remains constant within close tolerances.

The nominal volume flow can easily be set externally without tools using the scale. For easier site installation, controllers can be ordered and installed by size. The required volume flow is then simply and accurately set during commissioning.

The RN controllers are also available with acoustic cladding to reduce the case-radiated noise. The RS-A, RS-B, CA or CF/CS attenuators can additionally be fitted, when low noise output levels are required.

Economical Commissioning

The required volume flow can be set using the external scale on the RN controller by means of the settings on the arm without site flow measurement. The advantage over conventional dampers is that repeated measurements and adjustments by a qualified commissioning engineer are no longer required.

If the system pressure changes, e. g. due to the opening or closing of duct sections, the volume flows in the entire system change; this is not the case when type RN/RNS volume flow controllers are used.

The controllers respond immediately and adjust the damper positions directly so that the set volume flow is held constant over the entire differential pressure range.

The volume flow rate controller RN can be supplied with an electric actuator for changing the set value.

Simplified Installation

The Trox lip seal is available as an optional fitting for sizes 80 to 400. A sealed joint is achieved without additional materials, giving low installation costs. The cut edges of the adjacent circular ductwork should be deburred and cleaned prior to installation of the controller. Pre-treatment of the lip seal with a suitable agent simplifies insertion onto the spigot.

It is recommended that the circular duct be fixed to the spigot by means of 2 screws or 2 air-tight blind rivets, evenly spaced.

Acoustic Features

If required the circular attenuator CA or CF/CS with 50 mm insulation thickness or a rectangular attenuator, type RS-A and RS-B, can be used for sizes 100 to 315, to reduce discharge noise levels.

Volume Flow Controller Type RN with Actuator



Volume Flow Controller Type RND with Circular Attenuator CA or CF (fitted by customer)

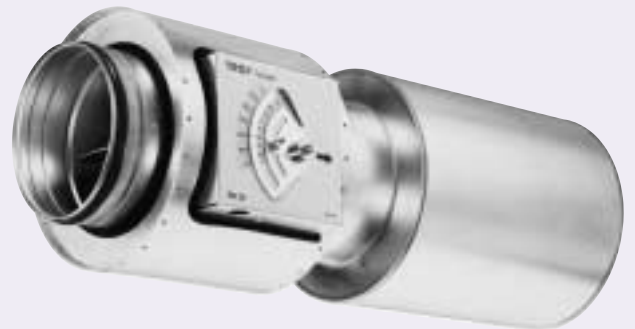

Volume Flow Controller Type RND with Attenuator RS-A (fitted by customer)

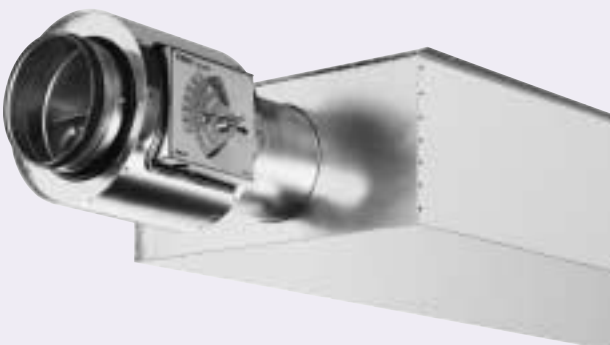

Air Heater, Electric and Hot Water



Construction · Dimensions

Design Features

Casing

- Spigots on both ends complying with DIN 24145 or DIN EN 13180 ducts. Beads for lip seals. (Lip seals can be factory-fitted or mounted onsite – for size 80, with adapter)
- Either with DIN EN 12220 flange on both ends, or with collar for fast connection system (not for RNS)
- Air leakage flow complies with Class A, DIN EN 1751

Volume Flow Control

- Mechanical system powered, no external power supply
- For supply or extract air

- Operating temperature 10 to 50°C
- Differential pressure range 50 to 1000 Pa
- Can be installed in any orientation
- Correct functioning even with unfavourable inlet and outlet flow conditions (minimum straight length of inlet duct 1.5 D)
- Control blade shaft supported in bearings
- Control bellows also acts as an oscillation damper
- Volume flow range 4 : 1
- Good volume flow tolerance
- Volume flow adjustment and resetting via external scale, scale accuracy approx. $\pm 4\%$
- The control blade mechanism is maintenance-free

Table 1: Dimensions in mm

Size	Casing								Flange					
	$\varnothing D_a$	$\varnothing D_{a1}$	$\varnothing D_i$	$\varnothing D_1$	L_1	L_2	L_3	L_4	$\varnothing D_2$	L_5	s	b	$\varnothing d$	n ¹⁾
80	79	181	-	-	250	232	330	-	-	-	-	-	-	-
100	99	200	100	111	310	232	310	298	132	290	3	25	9.5	4
125	124	220	125	136	310	232	310	298	157	290	3	25	9.5	4
160	159	262	160	171	310	232	310	298	192	290	4	25	9.5	6
200	199	300	200	211	310	232	310	298	233	290	4	25	9.5	6
250	249	356	250	261	400	317	400	388	283	380	4	25	9.5	6
315	314	418	315	326	400	317	400	388	352	380	4	30	9.5	8
400	399	498	398	411	400	317	400	388	438	380	4	30	9.5	8

1) n = No. of holes in flange

Table 2: Weight in kg

Size	RN	RNS	RND	Add. Weight	
				Flange	Actuator
80	1.4	1.4	2.2	-	1.0
100	1.8	1.8	3.6	0.6	1.0
125	2.0	2.0	4.0	0.7	1.0
160	2.5	-	5.0	1.0	1.0
200	3.0	-	6.0	1.4	1.0
250	3.5	-	7.3	1.8	1.0
315	4.8	-	9.8	2.5	1.0
400	5.7	-	11.8	3.9	1.0

RNS

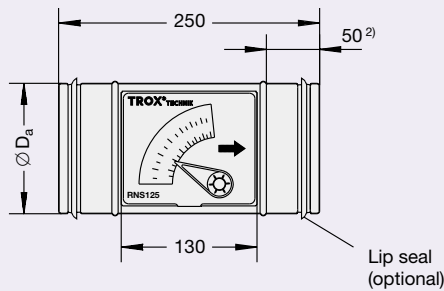

RN

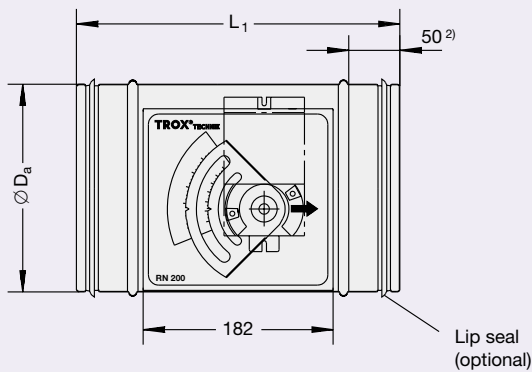

Flange Design

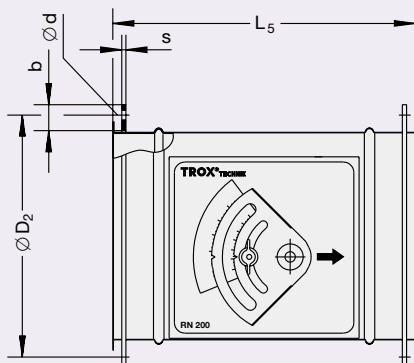

RND

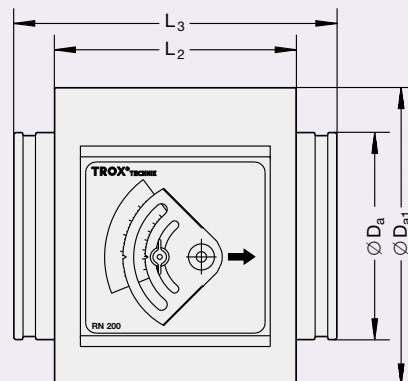

2) 30 for size 80

Construction · Dimensions

Actuator

- For set point change (not RNS)
- Electric 24 VAC, 24 VDC or 230 VAC
- Factory fitted
- Minimal space requirements due to compact construction

RND Acoustic Cladding

- To reduce case radiated noise
- Outer casing of galvanised sheet steel
- Sound-absorbent lining
- Rubber isolation elements to isolate outer casing

Materials

- Casing and control blade in galvanised sheet steel
- Stainless steel leaf spring
- Polyurethane bellows
- Plain bearings with PTFE coating

WL Hot-Water Air Heater

- Available as separate facility for reheating of the air flow
- Galvanised sheet steel frame
- To fit piping in accordance with DIN 24145 or DIN EN 13180, same connection diameter at both ends
- Copper pipes and aluminium blades
- Generally in two-row configuration
- Pipe connection R 1/2" via clamping ring coupling (installation to be carried out by customer)
- Maximum operating pressure 8 bar
- For hot water up to 100 °C
- Suitable for installation in horizontal or vertical air ducts with any air flow direction

EL Electric Air Heater

- Available as separate facility for reheating of the air flow
- Galvanised sheet steel frame
- To fit piping in accordance with DIN 24145 or DIN EN 13180, same connection diameter at both ends
- Heating elements in stainless steel 1.4541
- Overheating protection (automatically and manually resettable), fully wired in control box, with terminals for electrical connection
- Suitable for installation in horizontal or vertical air ducts, control box can be positioned at top or side
- 230 VAC single-phase (size 100 to 200), 400 VAC two-phase (size 250), 400 VAC three-phase (size 315 and 400)

Table 3: Dimensions in mm, weights in kg, heat output EL in kW

Size	Dimensions					Weights		Q̇ in kW
	∅D _a	R	S	T	N	WL	EL	
80	-	-	-	-	-	-	-	-
100	99	225	183	140	103	3.4	2.0	0.4
125	124	225	183	140	128	3.4	2.5	0.9
160	159	305	258	215	163	5.1	2.9	1.2
200	199	305	258	215	203	5.1	3.7	2.1
250	249	385	333	290	253	7.7	4.5	3.0
315	314	460	408	365	318	10.0	6.7	6.0
400	399	534	479	400	403	11.6	8.1	9.0

Raised Edge Both Ends

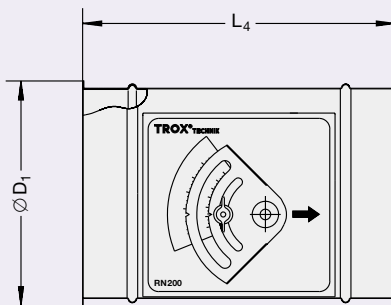

Spigot One End

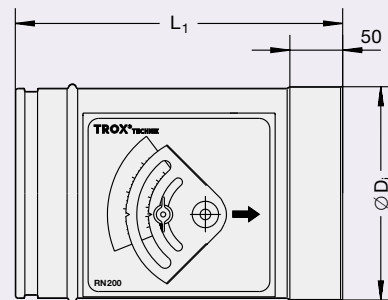

Hot-Water Air Heater WL

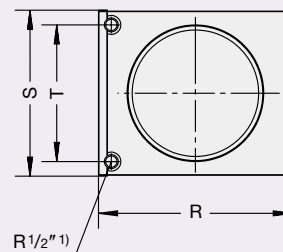
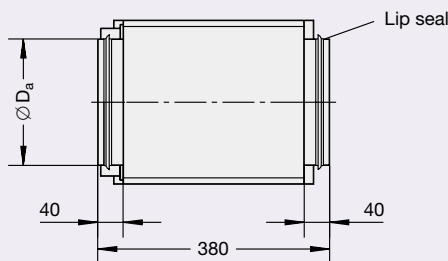

Electric Air Heater EL

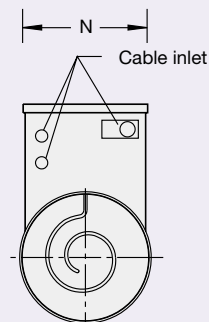
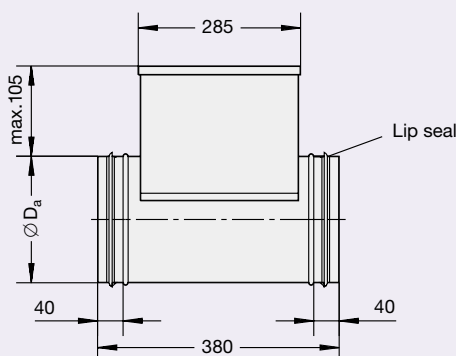

1) with supplied clamping ring union

Design Variants · Dimensions CA, CF and RS

Table 4: Dimensions in mm and weight in kg

Size	RS-A / RS-B														Weight	
	$\varnothing D_1$	$\varnothing D_{a3}$	C	B	H	L_7	L_8	E	F	R	G	K	M	RS-A	RS-B	
80	-	-	-	-	-	-	-	-	-	-	-	-	-	-	-	
100	100	99	100	222	160	1000	1250	120	180	61	160	-	140	8.0	10.0	
125	125	99	100	272	170	1000	1250	140	230	71	210	-	140	10.0	12.0	
160	160	124	160	412	210	1250	1500	170	330	81	310	190	140	18.0	21.0	
200	200	159	160	652	280	1500	1900	220	570	81	550	350	200	35.0	42.0	
250	250	199	250	902	310	1500	1900	255	835	81	800	550	200	44.0	56.0	
315	315	249	300	1002	360	1500	1900	285	935	101	900	600	200	55.0	67.0	

RS for size 400 not available

Table 5: Dimensions in mm and weight in kg

Size	CA050 / CF050								Weight							
	$\varnothing D_a$	$\varnothing D_{a2}$	$\varnothing D_{a4}$	L_6				CA050			CF050					
				500	1000	1500	2000	500	1000	1500	500	1000	1500	2000		
80	79	-	191	o	o	o	o	-	-	-	0.9	1.5	2.2	2.8		
100	99	200	211	x/o	x/o	o	o	4.0	7.0	-	1.1	1.8	2.5	3.2		
125	124	225	235	x/o	x/o	o	o	5.0	9.0	-	1.2	2.0	2.9	3.7		
160	159	260	262	x/o	x/o	o	o	7.0	12.0	-	1.4	2.4	3.3	4.3		
200	199	300	311	x/o	x/o	o	o	7.0	13.0	-	1.7	2.9	4.0	5.1		
250	249	350	368	x/o	x/o	x/o	o	9.0	16.0	22.0	2.1	3.5	4.8	6.2		
315	314	415	413	x/o	x/o	x/o	o	12.0	20.0	28.0	2.4	4.0	5.6	7.2		
400	399	500	461	x/o	x/o	x/o	o	15.0	25.0	34.0	3.1	5.1	7.1	9.1		

x = available lengths, type CA050

o = available lengths, type CF050

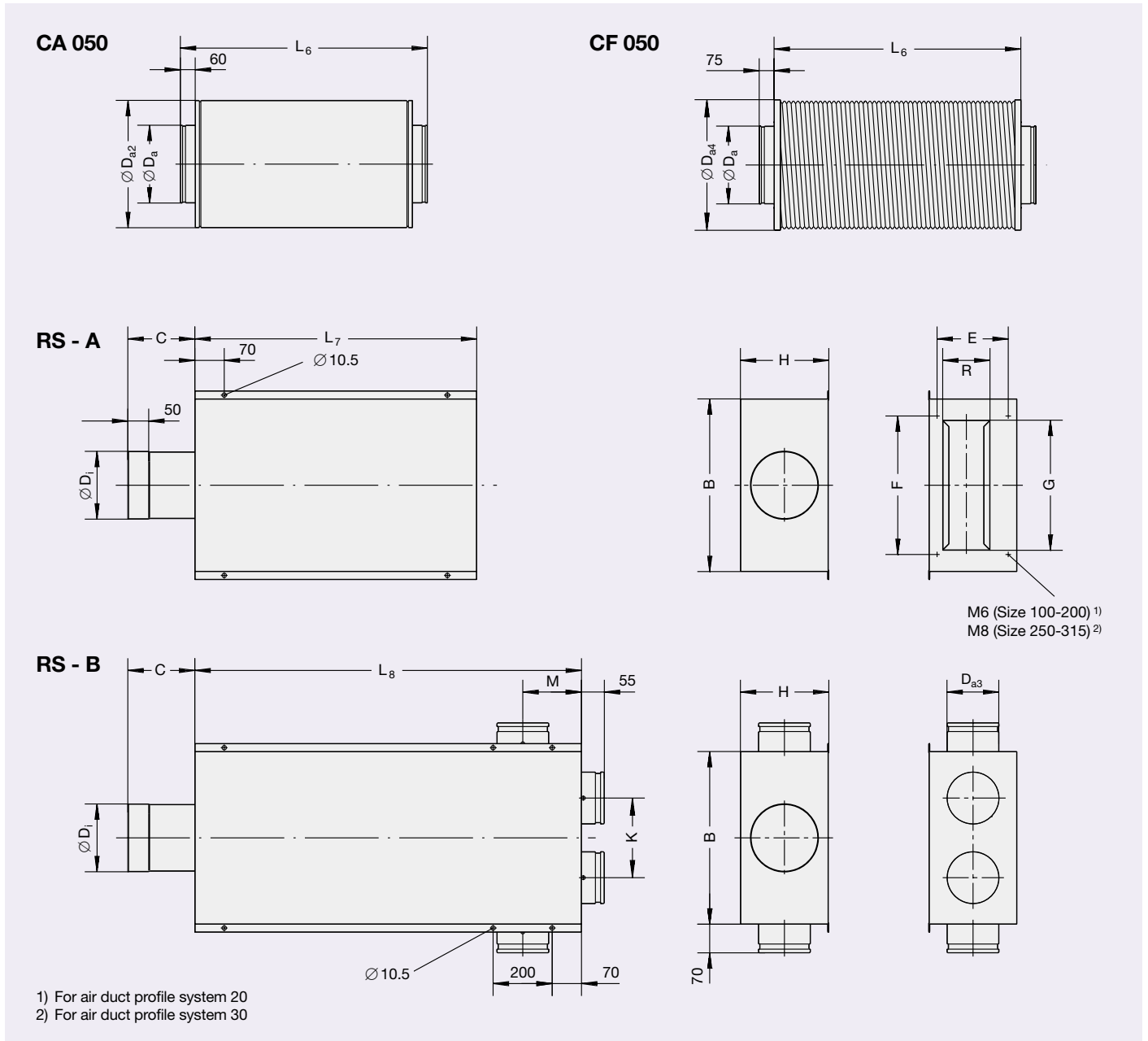

Nomenclature · Aerodynamic Data

Nomenclature

f_m in Hz: Octave centre frequency

L_W in dB: Sound power level (re 1 pW) of air-regenerated noise in connection duct

L_{W1} in dB: Sound power level (re 1 pW) of case-radiated noise for the respective installation situations depicted in Figures 1 to 5 as per Table 10

L in dB(A): A-weighted sound power level (re 20 μ Pa) of air-regenerated noise, assuming reflection attenuation and 8 dB/Oct. room attenuation

L_1 in dB(A): A-weighted sound pressure level (re 20 μ Pa) of case-radiated noise assuming an 8 dB/Oct. room attenuation

NC : Noise criteria rating of sound pressure level assuming 8 dB/Oct. room attenuation

\dot{Q} in kW: Heat output

t_e in °C: Inlet air temperature

t_a in °C: Discharge air temperature

\dot{m}_w l/h: Mass flow (water)

Δp_v kPa: Water pressure drop

PWW in °C: Warm water pump

\dot{V} in l/s or m³/h: Volume flow

Δp_g in Pa: Total pressure drop (measured 2D upstream and downstream of controller)

$\Delta p_{g \min}$ in Pa: Minimum total pressure drop

$\Delta \dot{V}$ in \pm %: Volume flow tolerance from set point (when directly connected downstream of a bend, a higher tolerance will occur)

$\Delta L_{-1 \text{ bis } 5}$ in dB: Correction value for case radiated noise

$\Delta L_{A1 \text{ bis } 5}$ in dB: Correction value for A-weighted case radiated noise

All noise levels determined in reverberant room.
Sound power levels determined and corrected in accordance with ISO 5135, December 1997.

Table 6: Aerodynamic Data

Size	\dot{V}		$\Delta \dot{V}$ in \pm %	$\Delta p_{g \min}$ in Pa
	in l/s	in m ³ /h		
80	11	40	20	100
	20	72	15	100
	30	108	10	100
	45	162	8	100
100	22	80	10	50
	40	144	8	50
	60	216	6	50
	90	324	5	50
125	35	126	10	50
	60	216	8	50
	100	360	6	50
	140	504	5	50
160	60	216	10	50
	105	378	8	50
	175	630	6	50
	240	864	5	50
200	90	324	10	50
	185	666	8	50
	275	990	6	50
	360	1296	5	50
250	145	522	10	50
	240	864	8	50
	435	1566	6	50
	580	2088	5	50
315	230	828	10	50
	380	1368	8	50
	690	2484	6	50
	920	3312	5	50
400	350	1260	10	50
	700	2520	8	50
	1050	3780	6	50
	1400	5040	5	50

Table 7: Performance Data for Hot-Water Air Heater

Size	\dot{V}		$\Delta p_{g \min}^*$ in Pa	PWW 60/40, $t_e = 15$ °C				PWW 90/70, $t_e = 15$ °C			
	in l/s	in m ³ /h		\dot{Q} in kW	t_a in °C	\dot{m}_w in l/h	Δp_v in kPa	\dot{Q} in kW	t_a in °C	\dot{m}_w in l/h	Δp_v in kPa
100	22	80	10	0.4	30	18	0.1	0.9	46	38	0.3
	40	144	20	0.6	26	24	0.2	1.3	40	55	0.6
	60	216	45	0.7	24	28	0.3	1.7	37	73	1.0
	90	324	90	0.8	22	33	0.4	2.2	30	96	1.0
125	35	126	20	0.5	27	22	0.2	1.1	42	51	0.7
	60	216	45	0.7	24	28	0.3	1.7	37	73	1.0
	100	360	110	0.8	21	35	0.4	2.3	34	102	1.0
	140	504	205	0.9	20	39	0.5	2.8	31	124	2.0
160	60	216	10	1.1	30	49	1.0	2.6	50	116	3.0
	105	378	25	1.6	27	68	1.6	3.8	44	167	6.0
	175	630	60	2.2	25	95	2.0	5.2	39	230	10.0
	240	864	110	2.8	24	120	4.0	6.3	36	279	14.0
200	90	324	20	1.4	28	62	1.0	3.4	46	151	5.0
	185	666	70	2.3	25	99	3.0	5.4	39	238	11.0
	275	990	140	3.0	24	132	4.0	6.8	35	302	16.0
	360	1296	230	3.6	23	157	6.0	8.0	33	355	21.0
250	145	522	15	2.3	28	100	1.0	5.7	47	253	3.0
	240	864	35	3.1	26	135	1.5	7.9	42	350	5.0
	435	1566	105	4.7	24	202	2.0	11.4	36	504	9.0
	580	2088	180	5.8	23	252	3.0	13.5	34	598	12.0
315	230	828	15	3.6	28	158	1.0	9.1	47	405	3.0
	380	1368	35	5.0	26	217	1.6	12.6	42	558	5.0
	690	2484	105	7.7	24	335	2.0	18.2	36	805	9.0
	920	3312	180	9.7	24	420	3.0	21.6	34	956	13.0
400	350	1260	15	5.5	28	241	1.0	13.8	47	611	4.0
	700	2520	55	9.1	26	394	2.0	21.4	40	949	8.0
	1050	3780	115	12.4	25	540	3.0	27.5	36	1215	12.0
	1400	5040	195	14.8	24	646	4.0	32.6	34	1443	16.0

* additional factor to be taken into consideration

Air-Regenerated Noise without Attenuator

Calculation

f_m	63	125	250	500	1k	2k	4k	8k
L_w	61	62	58	54	49	44	40	37
Reflection attenuation	20	14	9	4	1	0	0	0
Bend attenuation ¹⁾	0	0	0	0	1	2	3	4
Room attenuation ¹⁾	4	4	4	4	4	4	4	4
	37	44	45	46	43	38	33	29
A-weighting	-26	-16	-9	-3	0	1	1	-1
Corrected level	11	28	36	43	43	39	34	28

Result:

L approx. 47 dB(A) according to logarithmic addition, specified requirement is not fulfilled without duct attenuator.
 A circular attenuator CF050, 500 lg. is required.
 After repeating the calculation process, the result is L approx. 37 dB(A); the specification requirements are achieved.

1) See for example VDI 2081

Table 9: Air-Regenerated Noise

Size	\dot{V} in l/s in m³/h		$\Delta p_g = 100 \text{ Pa}$										$\Delta p_g = 250 \text{ Pa}$										$\Delta p_g = 500 \text{ Pa}$										$\Delta p_g = 1000 \text{ Pa}$									
			L_w in dB										L_w in dB										L_w in dB										L_w in dB									
			f_m in Hz										f_m in Hz										f_m in Hz										f_m in Hz									
			63	125	250	500	1000	2000	4000	8000	L in dB(A)	NC	63	125	250	500	1000	2000	4000	8000	L in dB(A)	NC	63	125	250	500	1000	2000	4000	8000	L in dB(A)	NC	63	125	250	500	1000	2000	4000	8000	L in dB(A)	NC
80	11	40	66	51	42	40	39	36	30	25	32	28	60	52	45	43	41	41	38	35	37	33	57	54	49	47	45	46	47	44	43	41	66	59	54	51	48	50	53	54	50	49
	20	72	67	55	47	39	35	38	35	30	33	29	60	56	51	47	42	43	41	38	40	35	64	60	53	51	47	47	46	45	41	68	63	57	55	52	51	53	54	50	49	
	30	108	58	57	53	44	40	42	39	35	38	34	59	61	57	51	46	46	45	44	43	39	62	64	59	56	51	49	50	49	47	44	68	67	62	59	56	53	54	55	52	50
	40	144	58	60	57	47	43	45	42	38	41	37	61	64	62	55	49	48	48	46	46	42	62	66	62	59	53	51	52	51	50	46	70	70	66	63	58	55	56	56	54	51
	45	162	55	61	56	49	44	46	43	39	42	37	63	66	64	57	50	49	49	48	48	43	65	68	64	62	55	53	54	54	52	49	71	71	68	64	60	57	57	58	56	52
100	22	80	68	50	42	38	31	24	16	<	26	20	65	52	48	45	42	39	33	26	36	31	67	57	54	51	47	46	47	43	45	41	73	64	60	55	50	51	54	56	51	51
	40	144	61	55	48	44	38	32	25	18	33	27	66	58	55	51	46	42	37	33	41	35	70	62	59	56	51	47	47	45	47	41	78	67	66	62	57	53	53	55	53	50
	55	198	62	58	50	47	41	36	29	23	36	30	68	63	59	55	51	45	41	36	45	39	72	65	63	60	55	51	48	47	50	44	78	69	68	65	61	56	54	56	57	51
	70	252	60	60	53	50	45	41	33	27	39	33	68	67	63	58	54	50	43	39	48	43	73	69	67	63	59	55	50	49	53	48	80	71	71	67	63	60	56	57	58	52
	90	324	53	62	56	53	50	47	41	36	44	39	68	68	65	60	56	53	45	43	51	45	75	71	70	66	62	58	52	51	56	51	81	73	74	71	66	64	59	58	62	56
125	35	126	55	50	43	40	35	26	18	16	29	24	62	56	51	48	45	42	36	30	40	34	62	61	56	53	48	49	50	45	47	44	66	59	59	55	50	55	57	58	54	53
	60	216	60	58	50	46	40	33	27	22	35	29	61	62	58	54	49	44	40	37	44	38	65	66	62	59	54	51	50	48	50	44	69	70	69	64	58	56	56	57	56	52
	90	324	62	63	55	51	46	41	35	32	41	36	63	68	63	59	54	48	44	42	49	43	67	70	68	64	59	55	52	51	55	48	72	73	72	69	64	61	58	59	60	54
	115	414	64	65	57	53	49	44	40	36	44	38	67	72	65	60	56	51	47	45	51	45	70	75	71	67	62	58	54	53	58	52	75	75	75	73	68	65	61	62	64	57
	140	504	65	69	59	55	52	46	43	40	46	41	68	76	67	62	58	54	50	48	53	47	71	77	73	69	64	61	57	56	60	54	76	76	77	76	70	67	63	63	66	61
160	60	216	59	54	46	43	40	38	28	26	36	30	63	59	52	50	47	48	40	32	44	40	63	61	56	54	51	53	51	45	50	46	66	62	60	58	56	58	59	57	56	52
	105	378	61	59	52	47	42	42	33	26	39	34	69	66	60	56	51	53	45	37	49	45	71	69	65	61	57	60	54	49	56	52	72	70	68	65	61	65	60	57	61	57
	145	522	61	59	53	48	45	44	37	29	41	36	72	69	63	59	54	55	48	41	52	47	73	71	69	65	60	62	56	50	59	55	75	74	73	70	65	70	63	59	65	62
	190	684	64	63	56	51	50	48	43	35	46	40	73	72	65	62	56	57	51	45	54	49	74	73	71	68	63	65	58	53	61	57	79	78	76	74	69	73	66	61	68	65
	240	864	62	66	58	54	53	51	47	41	49	43	72	72	64	61	57	58	52	46	55	50	77	75	73	70	64	66	59	54	63	58	80	79	79	77	71	75	67	63	70	67
200	90	324	57	50	41	40	39	37	34	27	35	29	64	55	47	48	48	49	47	40	46	41	63	56	51	52	54	55	54	49	52	48	64	58	54	55	59	61	62	59	59	55
	160	576	62	54	47	44	43	43	39	36	40	35	65	61	54	51	50	50	50	45	48	44	69	64	60	56	57	57	57	52	55	51	73	68	63	61	64	65	63	59	62	57
	230	828	65	58	50	48	48	44	40	45	40	67	65	65	57	54	52	53	52	45	50	46	71	69	63	59	58	58	58	53	56	52	79	72	68	65	65	66	65	62	64	59
	300	1080	69	61	53	50	50	53	48	43	49	45	77	70	60	57	55	56	55	51	54	49	79	74	65	62	60	60	60	56	58	54	76	76	71	67	65	67	65	62	64	59
	360	1296	70	64	55	52	52	55	50	46	51	48	75	72	61	58	57	59	57	52	56	51	79	76	67	63	61	62	62	58	60	56	81	79	74	69	67	69	67	64	66	61
250	145	522	47	41	41	42	39	39	34	26	36	31	53	55	51	50	50	51	47	42	48	44	66	58	55	55	57	59	56	52	55	51	67	61	58	59	62	66	63	61	62	58
	255	918	61	52	47	45	42	44	39	32	41	36	63	61	55	52	51	53	50	45	50	45	68	65	62	57	57	59	57	53	56	52	72	68	66	65	65	68	65	64	65	61
	365	1314	65	57	49	49	46	49	45	38	45	41	70	66	57	55	52	55	52	47	52	47	72	70	63	60	58	61	58	55	58	53	78	74	70	67	65	68	66	65	66	61
	470	1692	69	61	53	52	49	53	48	42	49	45	73	70	59	57	53	56	55	49	54	49	76	75	65	62	59	62	60	57	60	55	80	78	71	69	66	70	67	66	67	62
	580	2088	72	64	56	55	52	55	51	46	52	48	75	72	62	60	56	60	59	54	57	53	78	78	68	64	61	64	63	60	62	57	82	80	74	70	68	71	68	66	68	63
315	230	828	53	48	42	42	41	40	35	26	38	33	56	53	49	48	49	51	46	39	47	43	63	58	54	54	55	57	57	51	55	51	65	61	58	59	62	64	63	61	61	57
	400	1440	55	54	49	47	45	46	41	33	43	38	64	60	55	52	51	54	51	46	51	46	68	65	61	57	57	59	58	55	57	52	72	68	65	63	63	65	64	63	63	58
	575	2070	62	57	51	50	47	48	45	38	46	41	71	64	59	56	54	57	54	49	54	49	74	69	64	61	59	61	60	57	59	54	79	74	69	66	65	67	66	65	65	60
	750	2700	66	61	54	53	51	51	48	43	49	44	73	67	61	58	56	58	57	52	56	51	78	73	67	63	61	64	63	60	61	57	83	78	72	69	68	69	68	67	67	62
	920	3312	70	65	58	56	53	54	52	46	52	47	76	70	64	60	58	60																								

Case-Radiated Noise

Example

Given: Size 160
 $\dot{V} = 145 \text{ l/s or } 522 \text{ m}^3/\text{h}$
 $\Delta p_g = 500 \text{ Pa}$
 Specified sound pressure level in room 35 dB(A)
 with 4 dB/Oct. room attenuation with controller
 installed as in fig. 1

Required: Spectrum of air-regenerated noise in room

- 1) See page 9 for values
 2) See for example VDI 2081

Calculation

f_m	63	125	250	500	1k	2k	4k	8k
L_w ¹⁾	73	71	69	65	60	62	56	50
ΔL_1	25	23	20	18	10	9	9	4
Ceiling transmission loss ²⁾	4	4	4	4	4	4	4	4
Room attenuation ²⁾	4	4	4	4	4	4	4	4
	40	40	41	39	42	45	39	38
A-weighting	-26	-16	-9	-3	0	1	1	-1
Corrected level	14	24	32	36	42	46	40	37

Result: L_1 approx. 49 dB(A) using logarithmic addition. Specification is not achieved, additional acoustic cladding on the controller and customer fitted high density acoustic insulation to the outside of the ducting, as in Fig 4, is necessary. After repeating the calculation process with ΔL_4 the result is: L_1 approx. 23 dB(A), the specification requirements are achieved.

Table 10: Case-Radiated Noise

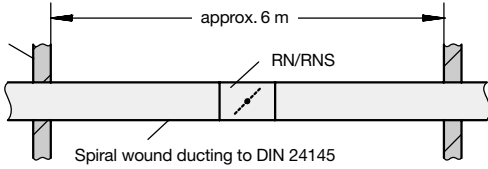
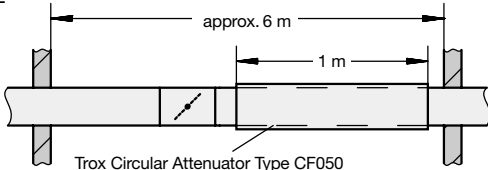
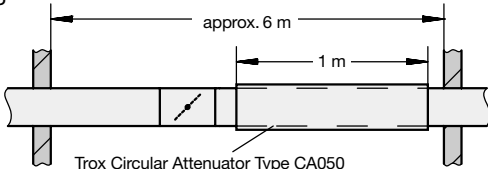
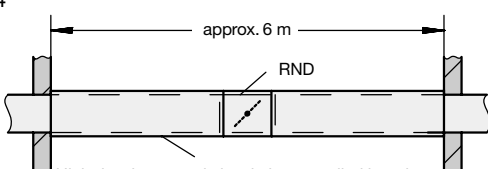
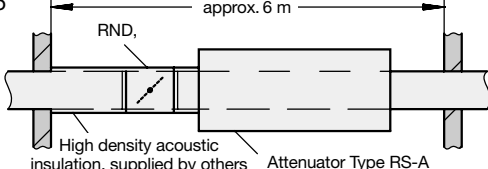
	$\Delta L_{1 \text{ to } 5}$	Size	$\Delta L_{W1 \text{ to } 5}$ in dB							$\Delta L_{A1 \text{ to } 5}$ in dB	$\Delta NC_{1 \text{ to } 5}$	
			f_m in Hz									
			63	125	250	500	1000	2000	4000			8000
<p>$L_{w1} = L_w - \Delta L_{1 \text{ to } 5}$ $L_1 = L - \Delta L_{A1 \text{ to } 5}$</p> <p>Fig 1</p>  <p>Wall</p> <p>approx. 6 m</p> <p>RN/RNS</p> <p>Spiral wound ducting to DIN 24145</p>	ΔL_1	80	37	34	33	22	18	12	12	10	13	11
100		35	32	31	21	17	12	12	10	13	11	
125		26	30	30	24	22	20	16	12	19	16	
160		25	23	20	18	10	9	9	4	9	8	
200		21	17	15	15	14	11	9	9	9	8	
250		19	15	14	14	13	11	9	9	9	8	
315		17	14	13	14	13	11	9	9	9	8	
400		17	16	9	7	6	4	6	15	5	4	
<p>Fig 2</p>  <p>approx. 6 m</p> <p>1 m</p> <p>Trox Circular Attenuator Type CF050</p>	ΔL_2	80	37	33	31	19	18	13	15	10	14	12
100		35	31	29	18	17	13	15	10	14	12	
125		27	30	28	22	22	21	19	12	20	17	
160		26	24	19	16	11	11	13	5	11	10	
200		23	18	14	14	15	13	13	10	11	10	
250		21	16	14	13	14	13	13	10	12	11	
315		20	16	13	13	14	14	14	11	12	11	
400		19	15	13	13	13	13	13	11	8	7	
<p>Fig 3</p>  <p>approx. 6 m</p> <p>1 m</p> <p>Trox Circular Attenuator Type CA050</p>	ΔL_3	80	42	38	35	23	21	16	18	13	17	15
100		40	36	33	22	20	16	18	13	17	15	
125		31	34	32	25	25	24	22	15	23	20	
160		30	27	22	19	13	13	15	7	13	12	
200		26	21	17	16	17	15	15	12	13	12	
250		24	19	16	15	16	15	15	12	13	12	
315		22	18	15	15	16	15	15	12	13	12	
400		20	17	14	14	14	13	13	11	9	8	
<p>Fig 4</p>  <p>approx. 6 m</p> <p>RND</p> <p>High density acoustic insulation, supplied by others</p>	ΔL_4	80	44	39	47	47	49	53	58	46	35	37
100		42	37	45	46	48	53	58	46	35	37	
125		33	35	44	49	53	61	62	48	41	42	
160		32	28	34	43	41	50	55	40	31	34	
200		28	22	29	40	45	52	55	45	31	34	
250		26	20	28	39	44	52	55	45	31	34	
315		24	19	27	39	44	52	55	45	31	34	
400		23	17	26	37	41	49	52	41	27	30	
<p>Fig 5</p>  <p>approx. 6 m</p> <p>RND,</p> <p>High density acoustic insulation, supplied by others</p> <p>Attenuator Type RS-A</p>	ΔL_5	80	33	30	32	23	22	16	18	12	17	15
100		31	28	30	22	21	16	18	12	17	15	
125		22	26	29	25	26	24	22	14	23	20	
160		21	19	19	19	14	13	15	6	13	12	
200		17	13	14	16	18	15	15	11	13	12	
250		15	11	13	15	17	15	15	11	13	12	
315		13	10	12	15	17	15	15	11	13	12	
315		13	10	12	15	17	15	15	11	13	12	

Correction values to assess the case-radiated noise of a system fitted with type RN controllers are dependent on a large number of variables, including supply or discharge air, duct type (rabbit pipes/ducts or spiral seam pipes, flexible pipes), duct shape (round or rectangular), radiating duct length, sound-absorbing insulation and ceiling systems. The stated values have been averaged for all sizes and apply for a max. room width of 6 m. Tolerances of up to ± 4 dB are possible.

Specification Text Controller Type R

Circular volume flow rate controllers for constant volume systems, mechanical system-powered (external power supply not required) for supply or extract air, differential pressure range 50 to 1000 Pa and DIN size circular ducts. Control blade shaft mounted in bearings, control bellows also provides pneumatic action oscillation damper, volume range 4:1. Good volume flow tolerance with external scale for adjustment and changing the volume flow, independent of gravity.

Materials:

Casing made of galvanised sheet steel, plain bearings in plastic. Polyurethane bellows.

Optionally available with:

Acoustic cladding RND consisting of 40 mm mineral wool and external casing of 1 mm galvanised sheet steel, to reduce case-radiated noise.

Actuator for RN/RND electric 24 VAC, 24 VDC or 230 VAC, for set point change.

Specification Text Attenuator Type RS

Attenuator type RS to reduce air-regenerated noise for supply or extract air, casing with acoustic lining, suitable for air velocities up to approx 20 m/s, circular spigot to fit RN controller, rectangular connection suitable for attachment of duct flanges, casing leakage meets class A, DIN EN 1751, meets cleanliness requirements class 3, VDI 2083 and class 100 to US Standard 209 b with respect to particle limits. Multi outlet spigots available, with volume control damper, for circular duct connection.

Materials:

Casing in galvanised sheet steel, lining in attenuator mineral wool, in inlet area with glass fibre facing, otherwise glass fibre matting suitable for air velocities up to approx. 20 m/s, non-flammable in accordance with DIN 4102, material class A2.

Order Code Type R

See Price List

	RN - A2 - BK	/	160	/	00	/	B 50	
Type			80 100 125 160 200 250 315 400 Size					Actuator ^{1) 7)} Make Actuator Accessories
Volume flow controller	RNS ⁶⁾							Matching Flange 00 without (basic construction) G2 with matching flange (both ends) ⁷⁾ D2 Lip seal ²⁾
Volume flow controller	RN							
With additional acoustic cladding	RND							
Material								
Surface powder-coated (RAL 7001) (not on flange variant)	P1							
Stainless steel (standard design is galvanised steel, which is provided when no code is entered)	A2							
Variant ⁷⁾								
Push-over spigot on one side ^{3) 4)}	EA							1) No entry when without actuator
Flange both ends ⁴⁾	FL							2) For size 80 with adapters (dimension L ₃)
Raised edge both ends ^{4) 5)}	BK							3) Opposite end with connecting bead
(Basic design is same diameter both ends, which is provided when no code is entered)								4) Not applicable for size 80
								5) Not in combination with acoustic cladding and powder coating
								6) Size 80 to 125, only available without acoustic cladding, without actuator
								7) Not applicable for RNS

The controller is supplied with a preset reference volume flow.
For construction with actuator, the minimum and maximum set volume flow must be adjusted.
Order details for the circular attenuator type CA, CF and CS are contained in leaflet 6/5/EN/..

Order Example

Make: TROX
Type: RN - A2 - BK / 160 / 00 / B 50

Order Code RS

	RS - A	/	160	/	00	
Type			100 125 160 200 250 315 Size			Matching flanges 00 none (standard construction) L3 slide on duct flange (for construction -A) D4 lip seal (for construction -B)
Attenuator	RS					
Design						
Standard construction	A					
Multi outlet unit	B					

Order Example

Make: TROX
Type: RS - A / 160 / 00

Order Details



Specification Text for Hot Water Air Heater, Type WL

Two-row air heater available for separate delivery, for installation down-line of R-series volume flow controllers as reheating facility for the air flow, for hot water up to 100 °C, spigot at both ends for DIN piping, pipe connection R 1/2", via clamping ring coupling.

Materials:

Casing in galvanised sheet steel, copper piping and aluminium blades.

Specification Text for Electric Air Heater, Type EL

Air heater available for separate delivery, for installation down-line of R-series volume flow controllers as reheating facility for the air flow, for connection to 230 VAC single-phase or 400 VAC two- or three-phase power supply, with manually and automatically resettable overheating protection, fully wired in control box, with spigots at both ends for DIN piping.

Materials:

Casing in galvanised sheet steel, heating elements in stainless steel 1.4541.

Order Code for Air Heaters

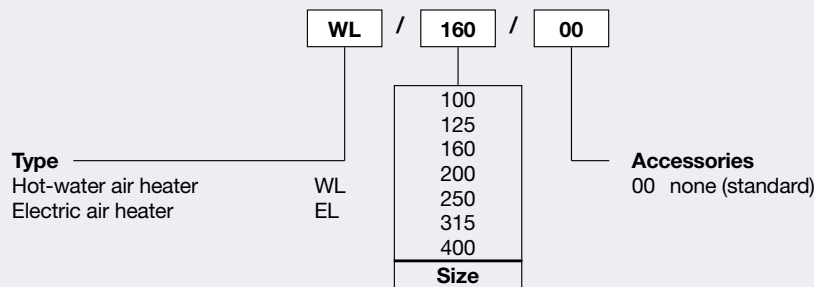

Order Example

Make: TROX
 Type: WL / 160 / 00