

# FIRE AND SMOKE CONTROL DAMPERS

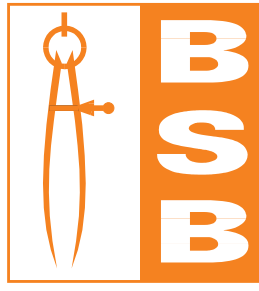

**FSD**  
**SERIES**

Manufacturers of Air/Fire/Smoke Control Products

FIRE / SMOKE CONTROL

# Product Specifications

## Introduction

The BSB FSD Series Fire and Smoke Control Damper is designed to stop the spread of Fire and Smoke through ducts, walls, ceilings and floors.

The product offers numerous control options and features, as required and specified by contractors, local fire and/or hospital authorities and consultants.

There are three casing variants - cases fully welded: square/rectangular, circular and flat oval with infinite sizing capability within minimum/maximum dimensions. All are suitable for low-high velocity and pressure applications.

Available to order are local and/or remote test panels with blade status indication; bespoke control management systems; factory fitted HEVAC approved installation frames; single and multiple assemblies. All are manufactured in compliance with the company's quality assurance procedures.

## Product Specifications

The combination fire and smoke dampers shall be the FSD Series complete with a factory fitted and tested control option module (Control Options 1, 5 & 9 according to application and mode of operation), as supplied by BSB Engineering Limited

### Casings

Casings shall be from 1.6mm (16swg) hot dipped zinc coated steel to BS EN 10142 DX51D + Z 275-N-A-C, with the inner bearing channels from 0.9mm (20swg) zintec plated mild steel. The bearing channel incorporates an integral formed low friction bush for the blades to rotate freely. All welds, seams and joints are coated with commercial grade zinc based aluminium paint. Where necessary, seams and joints shall be filled with sealant to comply with the requirements of HVCA ductwork specification DW144.

### Linkage, Blade Shafts and Bearings

The opposed blade action linkage shall be fully enclosed and outside the airstream and shall consist of drive discs from galvanised mild steel punched discs 2mm in thickness with zinc plated drive pins. Tie bars are from zinc plated mild steel 12mm x 3mm punched to fit onto zinc plated drive pins. Each blade is fitted with 2 number 19mm diameter zinc plated mild steel drive stub shafts. Oilite bronze bearings impregnated with mineral oil to ISO VG 100 (SAE30) and with wall thickness up to 3mm, ensure low friction rotation of the drive shaft.

### Side Jamb Gasket Seal

A formed 80mm wide stainless steel side seal gasket to provide lower leakage characteristics shall be fitted to the jamb on each side of the casing and will be from 0.3mm (0.010") stainless steel grade 301 515 60 BS5770.

### Blades

The blades shall be double skin aerofoil sections from 0.7mm (22swg) hot dipped zinc coated steel to BS EN 10142DX51D + Z 275-N-A-C or from 0.7mm (22swg) stainless steel grade 304.

### Control Option

The control option (Option 1, 5, or 9) shall be factory fitted to the damper stub duct section, the control option and damper assembly shall be bench tested for correct mode of operation. As standard, for failsafe closed application, the control option will incorporate a fusible link rated at 72°C.

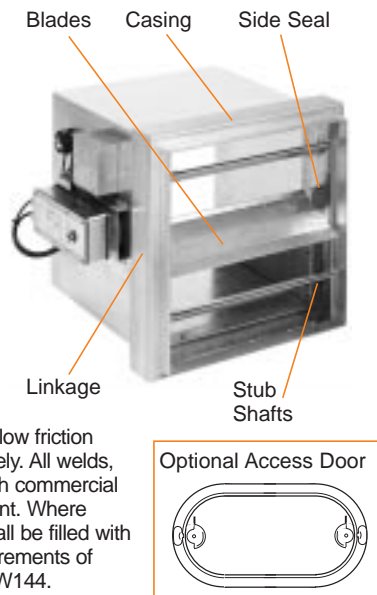

## Specifications and Testing

- ★ Standard construction is galvanised mild steel, stainless steel blades and casings available to order
- ★ Infinite sizing capability
- ★ Fully welded casing construction, riveted stub duct
- ★ Factory fitted HEVAC approved installation frames
- ★ Various control options
- ★ Compatible to B.M.S. and bespoke control systems
- ★ Factory Fitted Access Doors available
- ★ Unique "Firelock" blade design

## Features

- ★ Complies with BS476: Part 20: 1987.
- ★ Approved by LPC, assessment report CC 93913 for 4 hour applications.
- ★ Independent test of fusible link. BSRIA report 10707/1.
- ★ Independent performance test. BSRIA reports 10279/1 & 67230/2.
- ★ Conforms to HVCA Ductwork Specification DW144. Classes A, B & C casing leakage.
- ★ Conforms as relevant to Eurovent 2.2 and tested to BS EN 1751:1999 for casing leakage.
- ★ Quality Assurance accredited by NQA to BS EN ISO 9002:1994 Quality Assurance accredited by NQA to BS EN ISO 9002:1994.

## Model Description

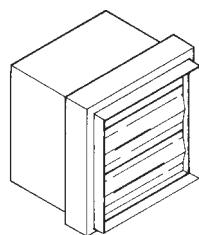

**Model FSD Rectangular Spigotfit**  
Square/Rectangular Spigot Connection  
Vertical or Horizontal Mounting

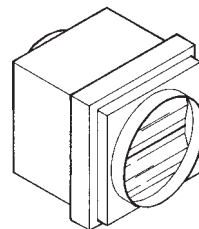

**Model FSD Circular Spigotfit**  
Circular Spigot Connection  
Vertical or Horizontal Mounting

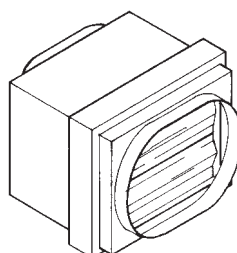

**Model FSD Flat Oval Spigotfit**  
Flat Oval Spigot Connection  
Vertical or Horizontal Mounting

# Dimensions and Weight Chart

## Model R

**Square/  
Rectangular  
Spigotfit  
Vertical or Horizontal  
Mounting**

**Note:**

On some units under 300mm high, reducing spigots are fitted effectively increasing the casing length. Please contact the Sales Office for full details.

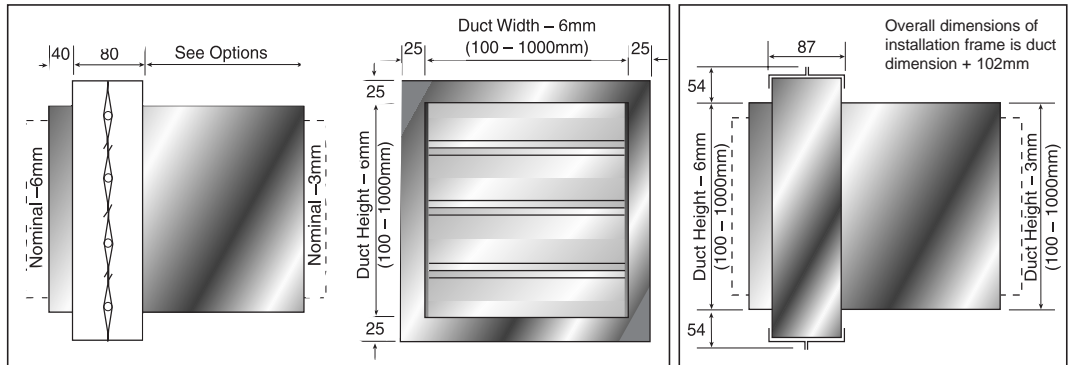

## Model C

**Circular Spigotfit  
Vertical or Horizontal  
Mounting**

| Duct Dia.  | Spigot "A" |
|------------|------------|
| 100-200mm  | 38 mm      |
| 224mm      | 45 mm      |
| 250-355mm  | 60 mm      |
| 400-630mm  | 70 mm      |
| 710-800mm  | 86 mm      |
| 850-1000mm | 50 mm      |

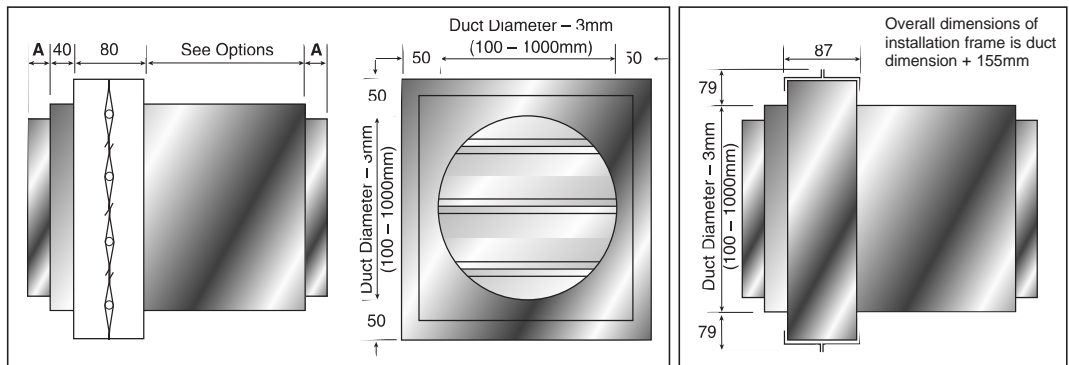

## Model O

**Flat Oval  
Spigotfit  
Vertical or  
Horizontal  
Mounting**

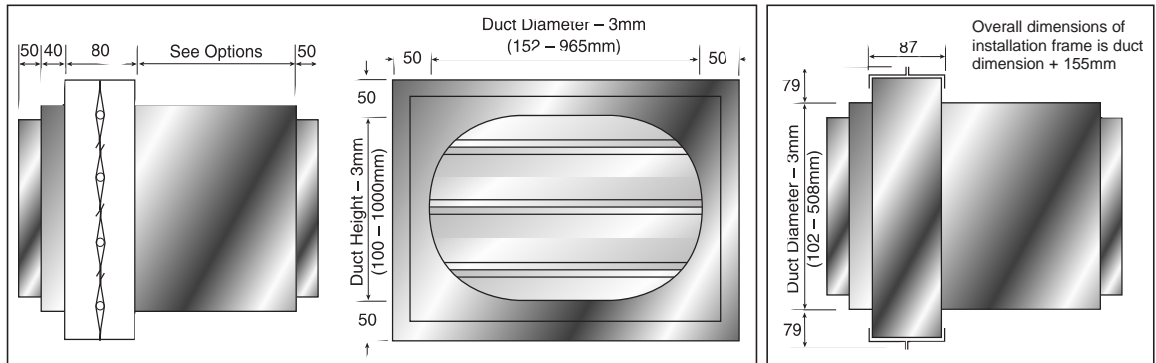

## Weight Chart (kg) (Model FSD-R)

| Damper<br>Height (mm) | Damper Width (mm) |     |     |     |     |     |     |     |     |      |
|-----------------------|-------------------|-----|-----|-----|-----|-----|-----|-----|-----|------|
|                       | 100               | 200 | 300 | 400 | 500 | 600 | 700 | 800 | 900 | 1000 |
| 100                   | 5                 | 7   | 9   | 11  | 13  | 15  | 17  | 18  | 20  | 22   |
| 200                   | 7                 | 9   | 11  | 12  | 14  | 15  | 18  | 19  | 21  | 23   |
| 300                   | 9                 | 11  | 13  | 14  | 15  | 16  | 18  | 20  | 22  | 24   |
| 400                   | 11                | 12  | 14  | 16  | 17  | 19  | 19  | 21  | 24  | 26   |
| 500                   | 13                | 14  | 16  | 18  | 19  | 20  | 21  | 23  | 25  | 27   |
| 600                   | 15                | 16  | 17  | 19  | 20  | 22  | 23  | 25  | 27  | 29   |
| 700                   | 17                | 18  | 19  | 21  | 23  | 25  | 26  | 28  | 29  | 32   |
| 800                   | 18                | 20  | 21  | 22  | 24  | 26  | 27  | 29  | 32  | 34   |
| 900                   | 20                | 21  | 23  | 24  | 25  | 28  | 29  | 32  | 34  | 36   |
| 1000                  | 22                | 23  | 24  | 26  | 27  | 29  | 30  | 33  | 35  | 38   |

1. The above reference values are for Model FSD - R
2. For Models FSDC and FSDO, apply the following respective multiplier: 1.1
3. to include a HEVAC/HVCA Installation Frame, apply the following respective multiplier: 1.1

# Control Options

## Option 1 Fusible Link Release - Manual Reset

**Control and Operation**  
Control Option 1 provides instant failsafe closure from a 72°C fusible link release and an external manual reset mechanism.

### Features

- Instant failsafe closure of the damper upon a rise in temperature within the duct, over 72°C (+/- 4°C).
- External Manual Reset.
- Local external visual indication of the damper blade position.
- External manual damper test facility.
- Fusible Link replaced from outside the duct.
- Closure Time approx. 1 second.

### Accessories

- Single pole microswitches

### Technical Specification

Closure Time:  
Approx. 1 second

### Weight

Option: 2kg

Damper: See Weight Chart (Page 2)

### Maintenance

As recommended in BSB Maintenance manual

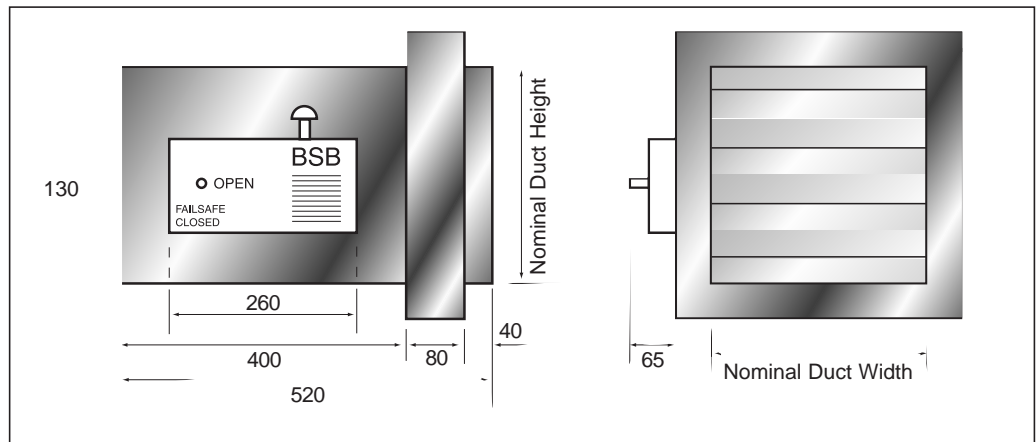

### Fusible Link

The fusible link fitted to option 1 as standard is rated at 72°C +/-4°C.

For inspection and or replacement, the pencil probe style fusible link used is easily removed external of the damper/ductwork assembly.

To remove, loosen the brass nut and the internally loaded fusible link can be withdrawn without the need for any special tools.

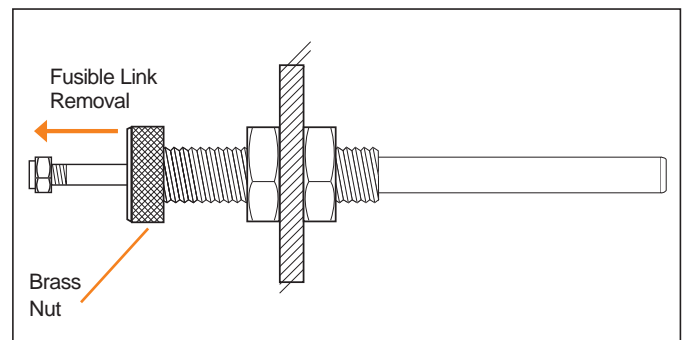

## Other Control Options

| Control Option | Control Operation                | Application           | Failsafe (as std.) | Associated Controls | Associated Accessories  |
|----------------|----------------------------------|-----------------------|--------------------|---------------------|-------------------------|
| 5 *            | Fusible Link Spring Return Motor | Fire/Smoke Smoke Vent | Close<br>Open      | Control Panel       | Microswitch/Access Door |
| 9 *            | Spring Return Motor              | Fire/Smoke Smoke Vent | Close<br>Open      | Control Panel       | Microswitch/Access Door |

\* When applicable, voltages must be applied

# Control Options

## Option 5 Fusible Link and/or Electrical Release – Automatic Electrical Reset – Local Test Switch Facility

**Control and Operation**  
Control Option 5 provides instant failsafe closure from a 72°C thermal link and/or remote electrical release on interruption of the mains power supply. The damper is automatically reset on resumption of the mains power supply. In addition, a Local Test Switch is provided for test and maintenance purpose.

### Features

- Instant failsafe closure of the damper upon a rise in temperature within the duct, over 72°C.
- Remote closure on interruption of mains power supply either 230 Volt AC or 24 Volt AC/DC.
- Motor spring closure time approx. 16 secs.
- Automatic reset on resumption of mains power supply, motor running time approx. 150 seconds..
- Integral blade status indication.
- Thermal Fuse replaced from outside the duct.
- Facility to manually open damper external to duct.
- External indication of blade position.
- Local damper test switch facility.

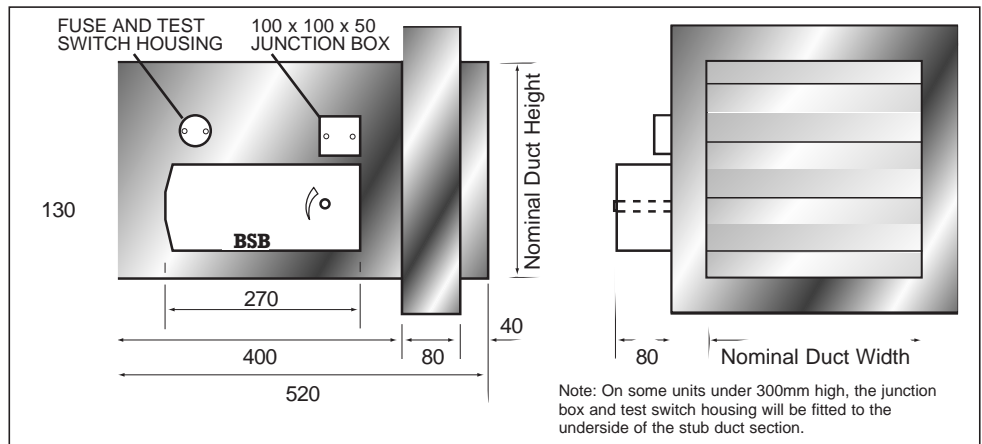

### Accessories

- Single pole microswitches
- Damper Control Panels

### Technical Specification

Closure Time:  
Approx. 16 seconds

### Weight

Option: 2kg  
Damper: See Weight Chart (Page 2)

### Electrical Data

Connection direct into terminal block with live-neutral-earth connection

### Maintenance

As recommended in BSB Maintenance manual

### Fusible Link

The thermal fuse link fitted to option 5 as standard is rated at 72°C. Option 9 is fitted with the housing only.

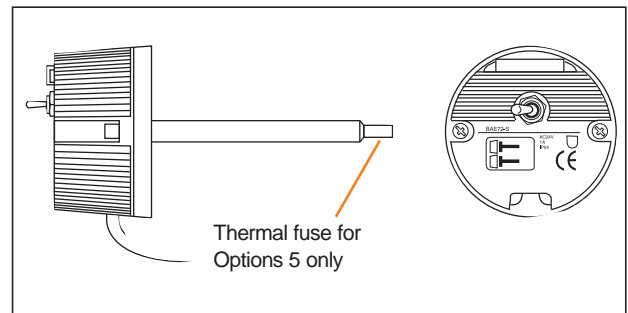

### Wiring Details

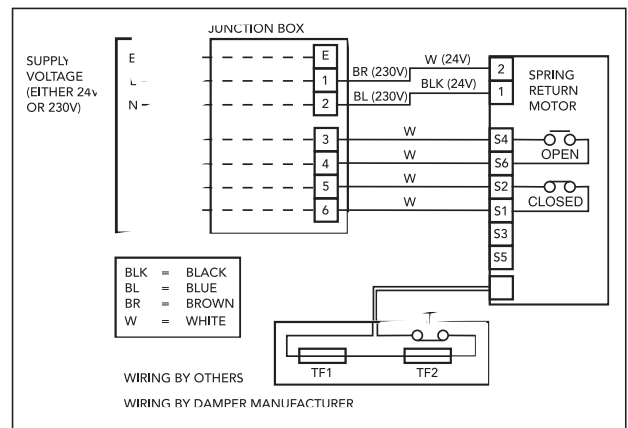

## Other Control Options

| Control Option | Control Operation         | Application              | Failsafe (as std.) | Associated Controls | Associated Accessories  |
|----------------|---------------------------|--------------------------|--------------------|---------------------|-------------------------|
| 1              | Fusible Link Manual Reset | Fire                     | Close              | N/A                 | Microswitch/Access Door |
| 9 *            | Spring Return Motor       | Fire/Smoke<br>Smoke Vent | Close<br>Open      | Control Panel       | Microswitch/Access Door |

\* When applicable, voltages must be applied

# Control Options

## Option 9 Electrical Release – Automatic Electrical Reset – Local Test Switch Facility

**Control and Operation**  
Control Option 9 provides a normally closed damper with remote electrical failsafe open, on interruption of the mains power supply. The damper is automatically reset on resumption of the mains power supply. In addition, a local test switch is provided for testing and maintenance purposes.

### Features

- Failsafe opening of the damper upon interruption of the mains power supply, either 230 volt AC or 24 volt AC/DC.
- Motor spring opening time approx. 16 secs.
- Automatic reset on resumption of mains power supply, motor running time approx. 150 seconds.
- Facility to manually open damper external of duct.
- Integral blade status indication.
- Local test switch facility.

### Accessories

- Single pole microswitches
- Damper Control Panels

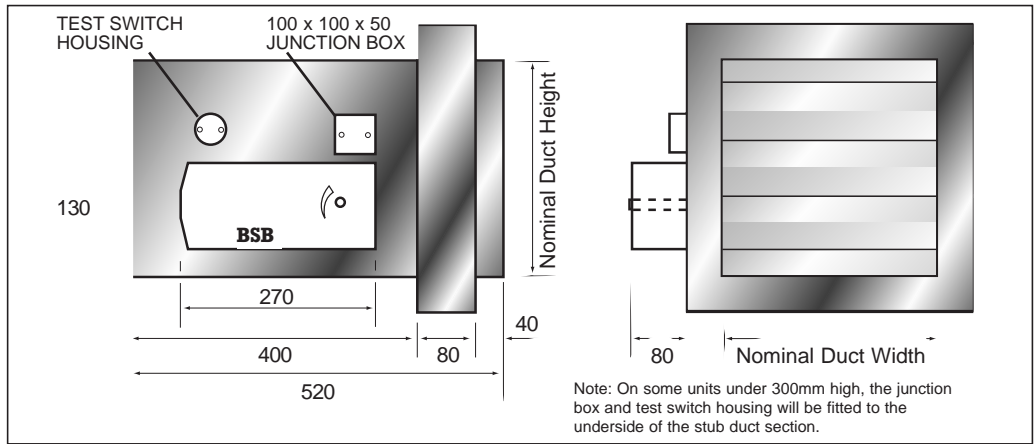

### Technical Specification

Running Times:  
Motor: Approx. 150 secs  
Motor (Spring Return):  
Approx 16 secs

### Weight

Motor: 3kg  
Damper: See Weight Chart (Page 2)

### Maintenance

Motor: Maintenance Free  
Damper: As recommended in BSB Maintenance Manual

### Fusible Link

The thermal fuse link fitted to option 5 as standard is rated at 72°C. Option 9 is fitted with the housing only.

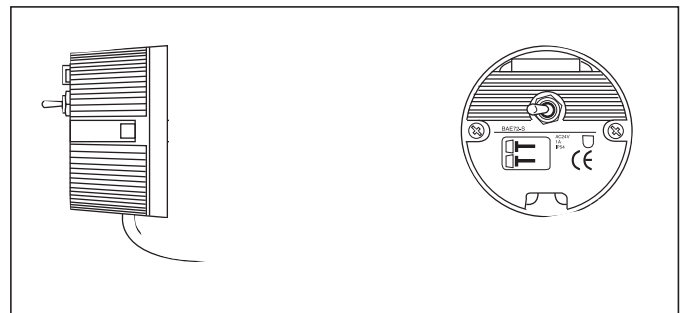

### Wiring Details

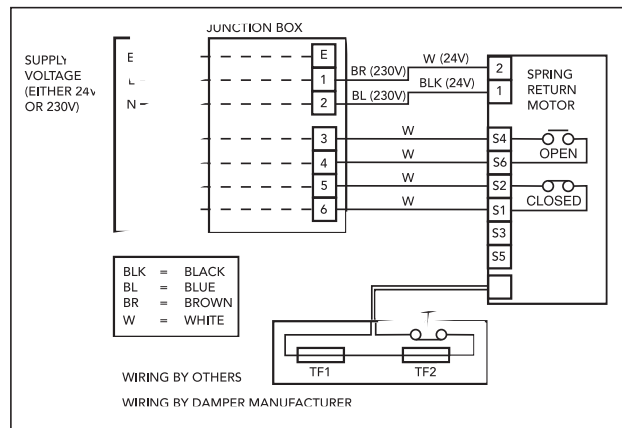

## Other Control Options

| Control Option | Control Operation                | Application              | Failsafe (as std.) | Associated Controls | Associated Accessories  |
|----------------|----------------------------------|--------------------------|--------------------|---------------------|-------------------------|
| 1              | Fusible Link Manual Reset        | Fire                     | Close              | N/A                 | Microswitch/Access Door |
| 5 *            | Fusible Link Spring Return Motor | Fire/Smoke<br>Smoke Vent | Close<br>Open      | Control Panel       | Microswitch/Access Door |

\* When applicable, voltages must be applied

# Performance Characteristics and Installation

## Open Pressure Drop Characteristic Curve

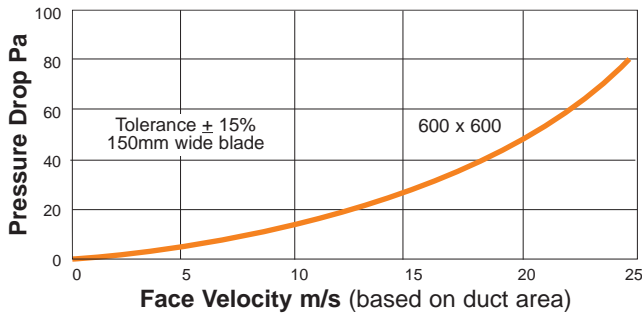

## Leakage Characteristic Curves (Blades Closed)

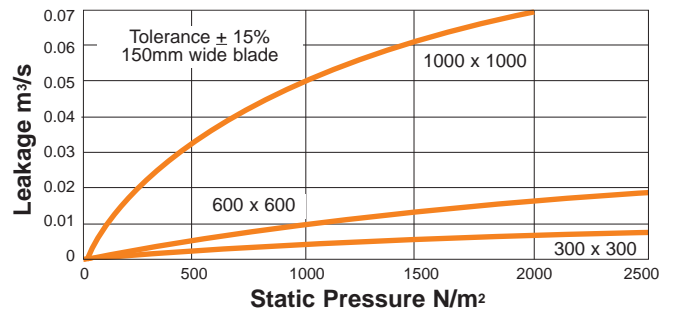

## Frame

All FSD Fire Smoke Dampers are available with factory fitted Installation Frames. The frame is designed to allow, under fire conditions, expansion of the damper.

Where fire dampers are mounted in series, each damper will be fitted with its own frame. This type of frame is suitable for a maximum duct size of 2000mm wide x 1000mm high.

For larger duct sizes, dampers can be fitted with an installation frame if agreed with the appropriate authority or district surveyor. Alternative fixings are possible using peripheral fixing angles (by others).

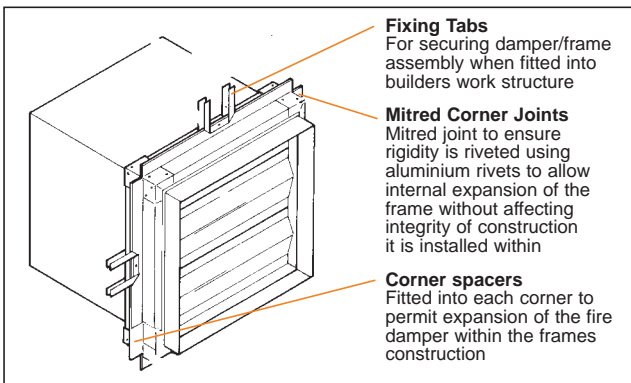

### Special Dry Wall Partition Installation Frame

The detail illustrated is proposed for acceptance by the specifying authority as an alternative method to install FSD Series Fire/Smoke Dampers into partition style walls. Dimension "A" would normally be 50mm, unless otherwise specified.

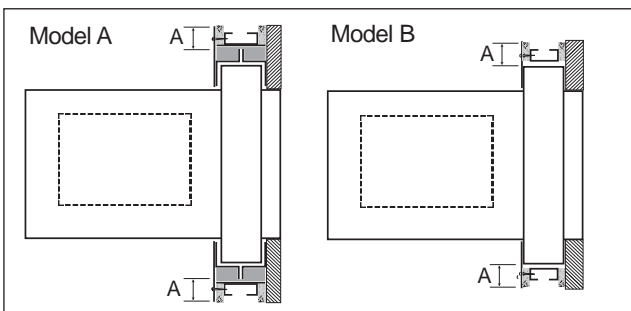

## Installation

### Codes of Practice

The frame should be installed centrally within the thickness of the surrounding wall or floor, or, in the case of thick walls or floors, the centre line of the frame should be at least 50mm away from the nearest face.

Where more than one duct penetrates a wall or floor, adjacent fire damper assemblies should be separated by builders work of a minimum thickness of 225mm. During installation, all fixing tabs should be bent out and built into the surrounding structure so as to ensure "positive fixing into the surrounding builder's work", as detailed in HEVAC installation frame specification HVC 6/5/83 rev1 - February 2002.

### Special Note:

All fire damper installations should be carried out to the satisfaction of the appropriate district surveyor, fire officer, and/or specifying authority as other approved methods of installation may well be used.

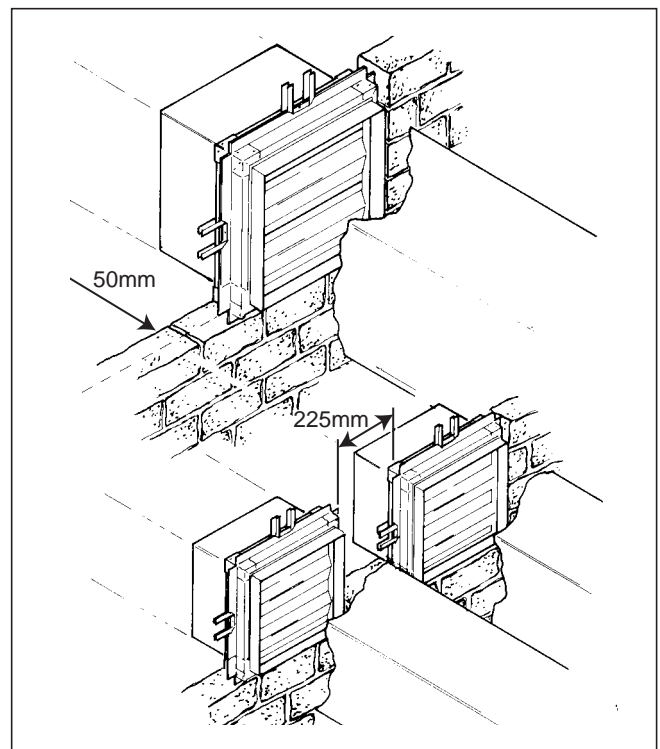

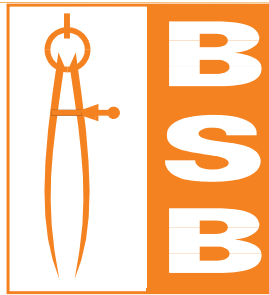

## Ordering Codes

Example:

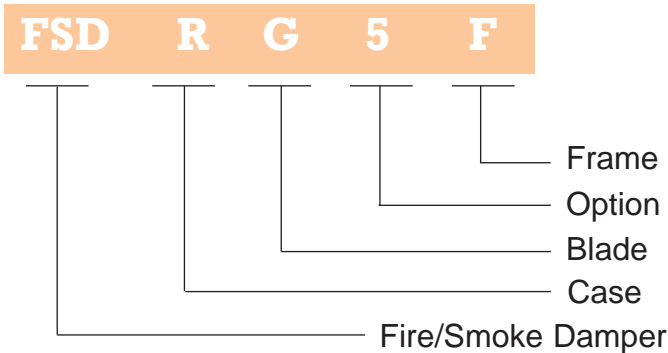

### FSD Fire/Smoke Damper

#### Case:

- R Rectangular Spigotfit
- C Circular Spigotfit
- O Flat Oval Spigotfit

#### Blade Material:

- G Galvanised Mild Steel
- S Stainless Steel (Grade 304)

#### Options:

- 1 Fusible Link - Manual Reset
- 5 Fusible Link and/or Electrical Release - Automatic Electrical Reset
- 9 Electrical Release - Automatic Electrical Reset

#### Frame:

- F Installation frame required

#### Special Note:

Options 5 and 9 - Voltages are required to be specified.

## BSB Product Range

|   |  |   |                                    |   |   |   |  |
|---|--|---|------------------------------------|---|---|---|--|
|  | <b>AD Series</b><br>Access Doors       |  | <b>EF Series</b><br>Easifit Damper |  | <b>FSD Series</b><br>Fire/Smoke Damper        |  | <b>SB Series</b><br>Single Blade Regulating Damper |
|  | <b>BD Series</b><br>Backdraught Damper |  | <b>FD Series</b><br>Fire Damper    |  | <b>HD Series</b><br>Heavy Duty Control Damper |  | <b>SC Series</b><br>Smoke Control Damper           |
|  | <b>DD Series</b><br>Duct Damper        |   |                                    |   |   |  | <b>SF Series</b><br>Slimfit Regulating Damper      |



### BSB Engineering Limited

Unit E, Tribune Drive, Trinity Trading Estate,  
Sittingbourne, Kent ME10 2PD

Tel: +44 (0)1795 422609. Fax: +44 (0)1795 429543

E-mail: [sabrunt@dial.pipex.com](mailto:sabrunt@dial.pipex.com)

[www.bsb-dampers.co.uk](http://www.bsb-dampers.co.uk)

BSB Engineering Services Ltd. reserves the right to modify or withdraw any specification without prior notice that may result from continuous product development. The information contained within this brochure is correct at the time of going to press.

BSBFSD. Feb. 2002

*Designed and Produced by Deenside Graphic*

Manufacturers of Air/Fire/Smoke Control Products