

Particulate Filter Cells

F770 and F771: Filter classes H 11 and H 13 in accordance
with EN 1822

F772: Filter class H 14 in accordance with EN 1822

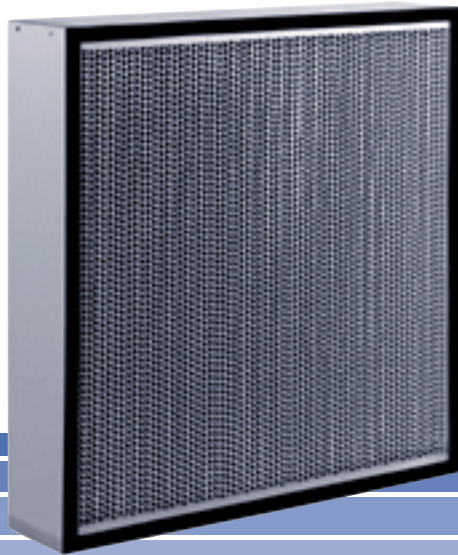

TROX[®] TECHNİK

Contents · Description

Description	2/3
Filter Technical Data F770 and F771	3/4
Filter Technical Data F772	5
Testing of Particulate Filter Cells	6
Specification Text	6

Particulate Filter Cells are high efficiency filters for the highest standards of air purity and aseptic conditions in many sensitive areas of industry, research, medicine, pharmacy and nuclear technology. The filter cells extract suspended particles, e.g. aerosols, toxic dust, viruses, germs etc. from the supply and extract air. Direction of air flow, and servicing side is optional..

The Particulate Filter Cells can be used in e.g.:

- **Trox KSF Filters;** available in various sizes, in single units or multiple assemblies with or without pre-filter housing (see leaflet F3 / 4 / EN / .).
- **Trox Ducted Casings;** apart from standard sizes the ducted casing can be supplied to match specific dimensions (see leaflet F3 / 5 / EN / .).

Particulate Filter Cells



- ① Filter casing (wood or metal)
- ② Filter media (glass fibre paper)
- ③ Spacer (aluminium or kraft paper)
- ④ Bonding (PU adhesive)
- ⑤ Sealing (flat profile, radiused profile or grooved profile gasket)

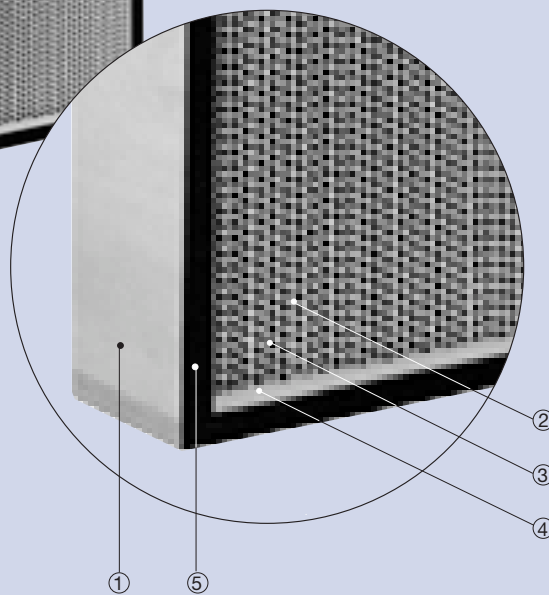

Technical Data F770 and F771

Filter Media

High quality glass fibre paper in various degrees of extraction efficiency is used selected to meet the necessary temperature and humidity requirements.

The glass fibre paper is located in the filter casing in close parallel pleats and is evenly and accurately positioned by corrugated aluminium or kraft paper separators.

Filter Casing

Casings are available in a choice of material, depending on requirements, eg fibre board, particle board, galvanized steel or stainless steel. The components are machine assembled to guarantee high stability.

Sealing

The Particulate Filter Cells are supplied as standard with a continuous flat profile gasket for secure sealing between the filter casing and housing. Filter cells with a radiused-profile gasket or grooved gasket can be supplied as an option.

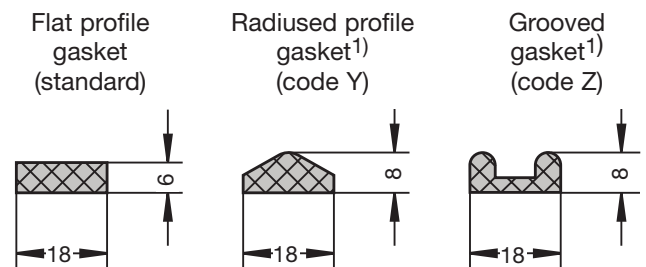

¹⁾ max. operating temperature 70 °C for filter cells with a radiused-profile gasket or grooved gasket

Technical Data

Filter type	F770	F771
Filter class to EN 1822 ²⁾	H 11	H 13
Extraction efficiency to EN 1822 in %	> 95	> 99.95
Initial pressure differential at nominal volume flow in Pa	125	250
Recommended final press.diff. in Pa	300	600
max. operating temperature in °C	100	100
max. relative humidity in %	100	100
Filter casing:	Construction	
– Fibre board	W	W
– Particle board	K	K
– Galvanized steel	M	M
– Stainless steel	–	E

²⁾ EN 1822: particulate filters (HEPA and ULPA)

Special Constructions (on request):

- Filter type F771 Construction P: As construction W but with kraft paper separators.
- Filter type F777 Construction E: As Filter type F771E, but for a max. operating temperature of 230°C.

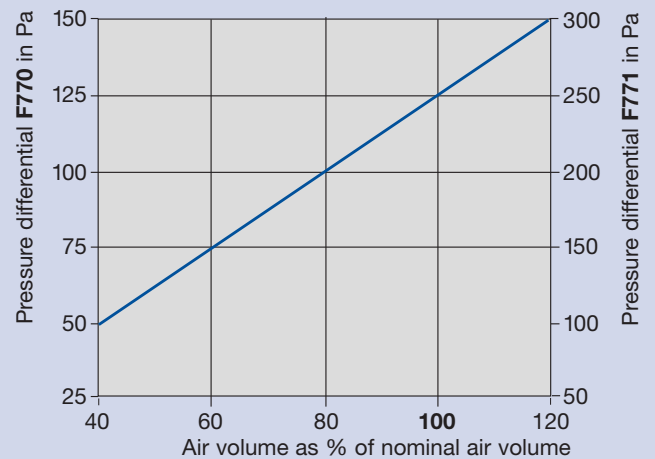

Deviation from the nominal volume flow within the range shown has no detrimental effect on the data for the filter cell; if the value falls below this range the degree of filtration will be improved.

Technical Data F772

Order Code for: Particulate Filter Cells

Filter class H 14 _____ Filter type: **F772**
 Fibre board casing _____ Construction: **W**
 Dimensions 610 x 610 x 150 mm _____ Code number: **02**
 Scan-Test _____ Standard: **0**
 Flat profile gasket _____ Standard: **0**

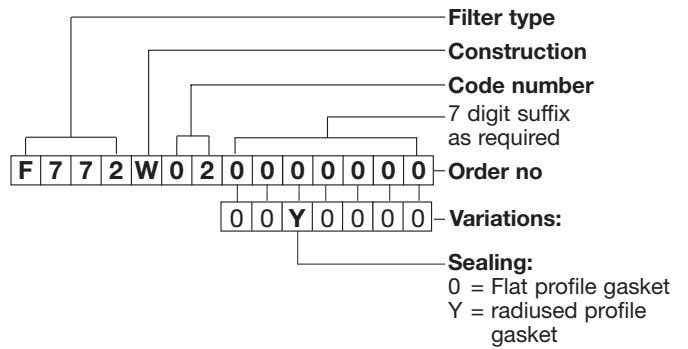

(For description of particulate filter cells see Pages 2 and 3).

Technical data

Filter type	F772
Filter class to EN 1822 ¹⁾	
Extraction efficiency to EN 1822	in %
Initial pressure differential at nominal volume flow	in Pa
max. operating temperature	in °C
max. relative humidity	in %
Filter casing:	Construction
- Fibre board	

¹⁾ EN 1822: particulate filters (HEPA and ULPA)

Deviation from the nominal volume flow within the range shown has no detrimental effect on the data for the filter cell; if the value falls below this range the degree of filtration will be improved.

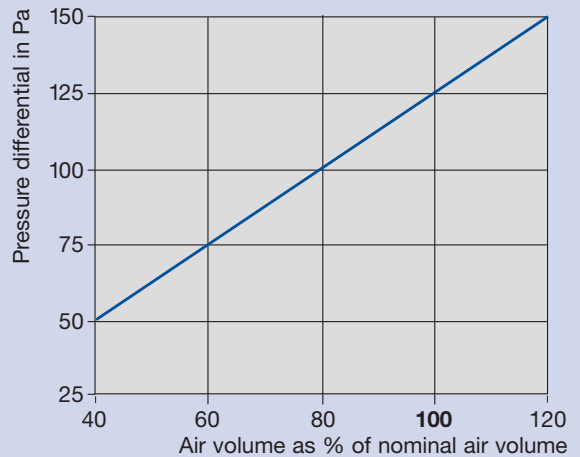

Code	Dimensions in mm (excluding gasket)			Nominal volume flow		Approx. weight in kg
	B	H	T	in l/s	in m³/h	
02	610	610	150	170	605	10.0
31	762	610	150	210	755	11.0
06	915	610	150	250	905	13.0
07	1220	610	150	335	1205	17.0
08	1525	610	150	420	1505	22.0
09	1830	610	150	500	1810	26.0
05	610	762	150	210	755	11.0
19	762	762	150	260	940	13.0
20	915	762	150	315	1130	15.0
30	1220	762	150	420	1505	20.0
26	1525	762	150	520	1880	25.0
27	1830	762	150	630	2260	29.0
22	915	915	150	375	1355	18.0
25	1220	915	150	500	1805	22.0
28	1525	915	150	630	2260	28.0
29	1830	915	150	755	2710	33.0

Dimensions

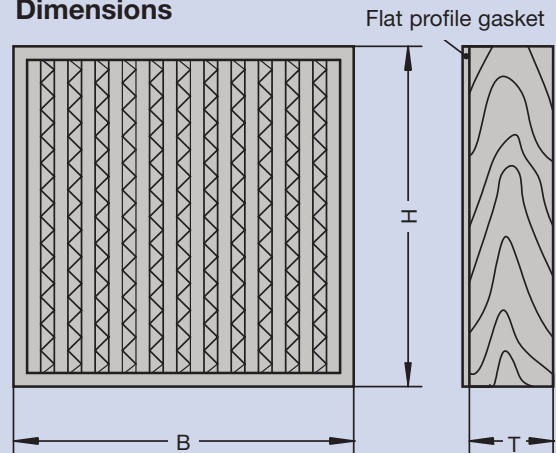

Dimensional tolerance + 0 mm
- 1 mm

Testing · Specification Text

Testing of particulate filters

EN 779: Particulate air filters for general room air-conditioning

This Norm is concerned with the performance testing of particulate air filters with an Efficiency against atmospheric dust of up to 98% (see leaflet: F0/2/EN/.) The particulate filters are divided into filter grades F5 to F9 according to their test results to EN 779.

Testing of high efficiency particulate filters EN 1822: High efficiency particulate filters (HEPA and ULPA)

This new European Norm testing procedure is based on particle counting using a liquid test aerosol of varying particle sizes.

The filters are rated by filter class (see table) according to extract efficiency or penetration.

Leak test

Tests are carried out in accordance with an oil mist test to EN 1822, a local scan test to verify the filters are free from leaks.

Trox offers the following:

- F771** Filter Panels individually leak tested:
O = Standard With oil-mist test or at increased price:
E = Scan-test Tested by particle counting

Specification Text

Item	Qty.	Description
		<p>Trox particulate filter cells F770 and F771 consisting of: Fibre board, particle board, galvanized steel or stainless steel with flat profile gasket on one side. High quality glass fibre paper filter media with aluminium or kraft paper spacers. Particulate filter cells F770 and F771 are type-tested at the factory according to EN1822. They are packed in damage resistant cartons for transportation.</p> <p>Trox particulate filter cells F772 consisting of: Fibre board casing with flat profile gasket adhered on one side. Filter media of high quality glass fibre paper with aluminium separators. The filter cells are factory tested by the Scan-test to ensure they are free from leaks and packed in damage resistant cartons for transportation.</p>
		<p>Technical data: Filter class to EN 1822 _____ Extraction efficiency to EN 1822 _____ % Dimensions (B x H x T) _____ mm Nom. volume flow _____ l/s (m³/h) Initial differential pressure _____ Pa max. operating pressure _____ °C max. relative humidity _____ % Net weight _____ kg Order no _____ Manufacturer: Trox</p>
		Price / Each