

# Minipleat Filter Cells

F756 to F759: Filter classes F6 to F9 in accordance with EN 779

F780 and F781: Filter classes H11 and H13 in accordance with EN 1822

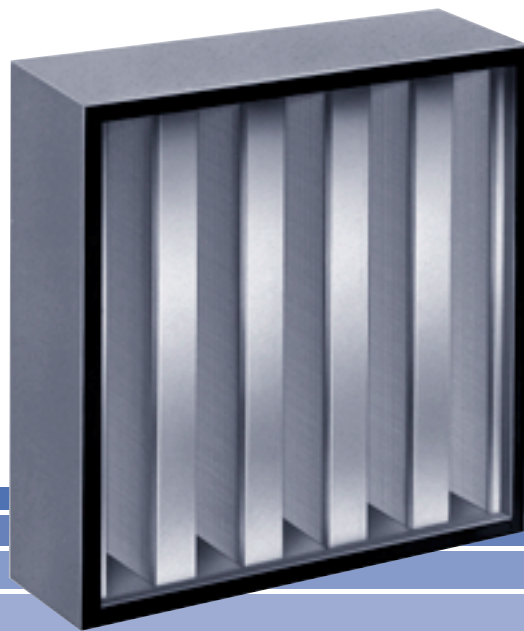

**TROX<sup>®</sup> TECHNİK**

# Contents · Description

Description	2
Filter Technical Data F 756, F 757 and F 759	3/4
Filter Technical Data F 780 and F 781	3/5
Testing Specification Text	6

Minipleat Filter Cells are used as prefilters for the extraction of dust particles or as high efficiency filters for the extraction of suspended particles, e.g. aerosols, toxic dust, viruses, germs etc. from supply and extract air.

Special features of these filter cells are the coordination of filter size, rated volume flow, pressure differential, dust holding capacity and service life.

The filters are designed for high volume flows and extended service life.

The Minipleat Filter Cells fit into frame assemblies or ducted casings and housings for installation into walls and ducting. Air flow direction, assembly position and servicing side is optional.

Minipleat filter cells are used as pre- and main filters e.g. in:

- **Trox filter wall** for filter cells supplied as standard in various heights and widths for up to 6 filter cells side by side or one above the other (see leaflet: F2/3/EN/.).
- **Trox KSF filters** supplied in various sizes as a single unit or multiple assembly (see leaflet: F3/4/EN/.).
- **Trox duct casing** for filter cells supplied as standard in various heights and widths for up to 4 filter cells side by side or one above the other (see leaflet: F3/5/EN/.).

## Minipleat Filter Cells

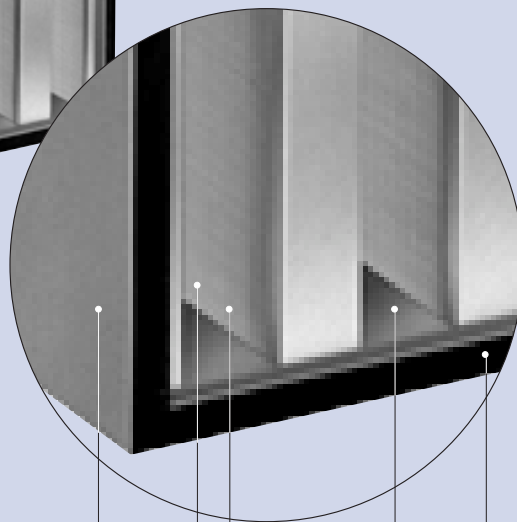
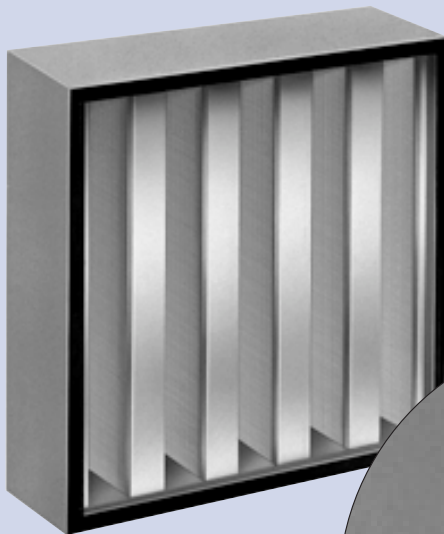

- ① Filter casing (wood or metal)
- ② Filter media (cellulose or glass fibre paper)
- ③ Spacer (textile threads)
- ④ Bonding (two-pack polyurethane compound)
- ⑤ Seal (flat profile or grooved gasket)

① ② ③ ④ ⑤

# Filter Technical Data

## Filter media

The filter media used includes high quality cellulose or glass fibre paper selected to meet the necessary temperature and humidity requirements.

The filter media is folded into closely spaced narrow pleats with textile thread spacers ensuring uniform spacing of the pleats.

## Filter casing

Casings are available in a choice of material depending on requirements e.g. fibre board, particle board, galvanized sheet steel, aluminium or stainless steel. The filter components are machine assembled to guarantee high stability.

## Sealing

The Minipleat Filter Cells are supplied with a flat profile gasket as standard for secure sealing between filter and holding frame. Filter cells F780 and F781 can be supplied with a grooved seal as an option.

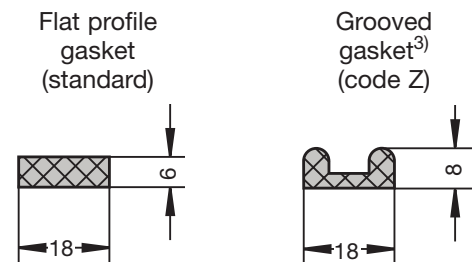

<sup>3)</sup> Max. operating temperature 70 °C

## Filter media data

Filter type	F756	F757	F759
Filter class to EN 779 <sup>1)</sup>	F6	F7	F9
Average Efficiency in %	65	85	95
Initial pressure differential at rated volume flow in Pa	120	140	180
Rec. final pressure differential in Pa	450	450	450
max. operating temperature in °C	80	80	80
max. relative humidity in %	90	100	100
Casing:	<b>Construction</b>		
- Fibre board	<b>W</b>	<b>W</b>	<b>W</b>
- Galvanized sheet steel	<b>M</b>	<b>M</b>	<b>M</b>
- Stainless steel	<b>E</b>	<b>E</b>	<b>E</b>

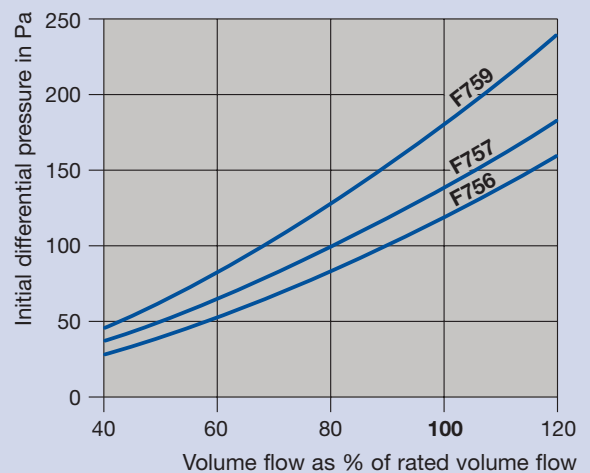

Filter type	F780	F781
Filter class to EN 1822 <sup>2)</sup>	H 11	H 13
Extract. efficiency to EN 1822 in %	> 95	> 99.95
Initial pressure differential at rated volume flow in Pa	125	250
Rec. final pressure differential in Pa	300	600
max. operating temperature in °C	80	80
max. relative humidity in %	100	100
Casing:	<b>Construction</b>	
- Fibre board	<b>W</b>	<b>W</b>
- Galvanized steel	<b>M</b>	<b>M</b>
- Stainless steel	<b>E</b>	<b>E</b>

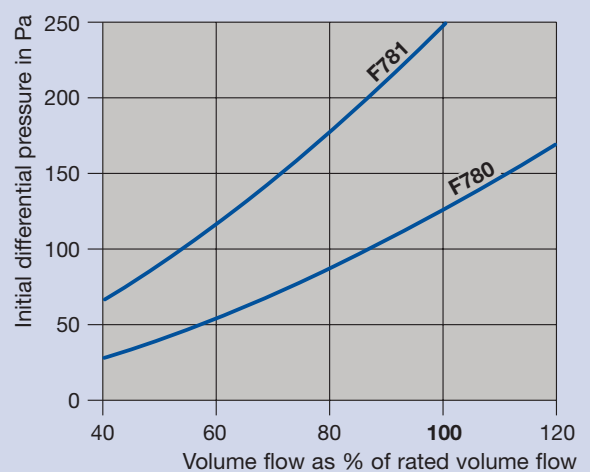

Deviation from the nominal volume flow within the range shown has no detrimental effect on the filter data for the Minipleat Filter Cells; if the value falls below this range, the degree of filtration will be improved.

<sup>1)</sup> EN 779: Particulate air filters for general room air conditioning

<sup>2)</sup> EN 1822: High efficiency filters (HEPA and ULPA)

# F756, F757 and F759

## Order Code Minipleat Filter Cells

Filter class F9 \_\_\_\_\_ Filter type: **F759**  
 Fibreboard filter casing \_\_\_\_\_ Construction: **W**  
 Dimensions 610 x 610 x 292 mm  
 for nominal volume flow of  
 (1400 l/s) 5000 m<sup>3</sup>/h \_\_\_\_\_ Code no.: **92**  
 Flat profile gasket (standard)

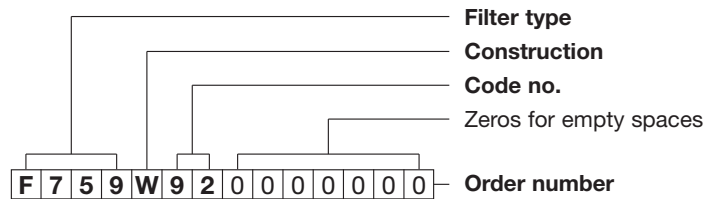

### Dimensions: Code number 91 and 92

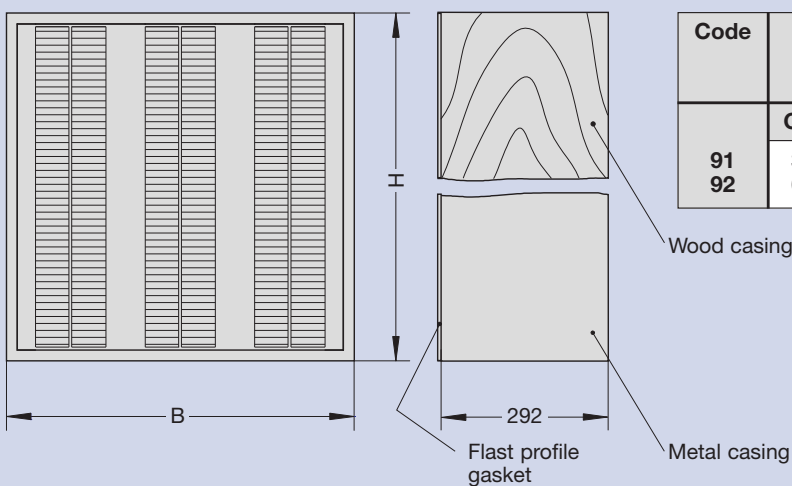

Code	Dimensions in mm			Nominal volume flow		Weight in kg approx.
	B	H	T	in l/s	in m <sup>3</sup> /h	
<b>91</b>	305	610	292	700	2500	9.0
<b>92</b>	610	610	292	1400	5000	15.0

**Construction W, M and E**

Dimensional tolerance + 0 mm  
 - 1 mm

All volume flow figures in l/s have been rounded off, then converted to m<sup>3</sup>/h.  
 Weights are net excluding packaging;  
 Weight of packaging per unit approx. 0.5 kg.

# F780 and F781

## Minipleat Filter Panels Order Code (Example 1)

Filter class H 13 \_\_\_\_\_ Filter type: **F781**  
 Galvanized sheet steel filter casing Construction: **M**  
 Dimensions 610 x 610 x 292 mm Code no.: **61**  
 With flat profile gasket Standard: **0**  
 With standard filter area Code no.: **000**  
 Oil mist test Standard: **0**

## Minipleat Filter Panels with large filter areas (Example 2) with large filter area

Filter class H 13 \_\_\_\_\_ Filter type: **F781**  
 Galvanized sheet steel filter casing Construction: **M**  
 Dimensions 610 x 610 x 292 mm Code no.: **61**  
 With flat profile gasket Standard: **0**  
 With large filter area Code letter: **S**  
 Oil mist test Standard: **0**

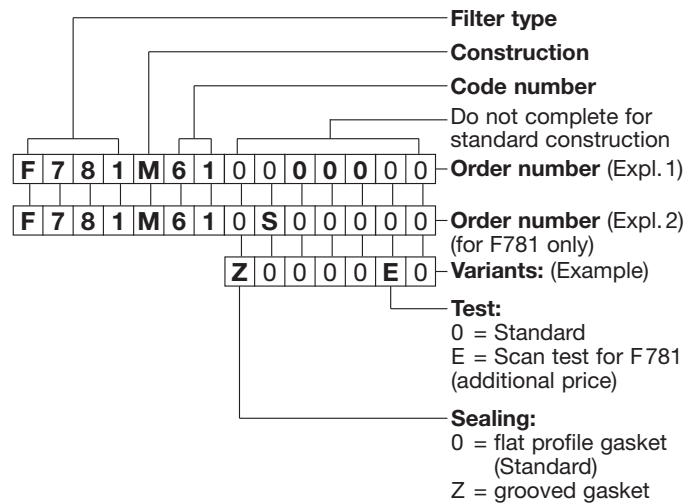

### Dimensions: Code nos. 91 and 92

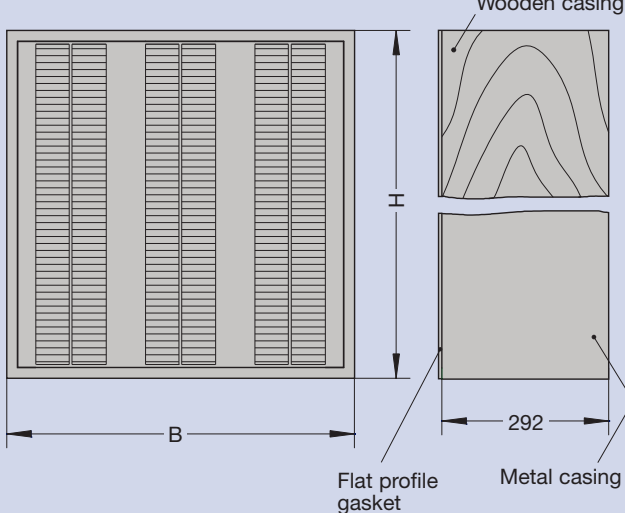

### Dimensions: Minipleat filter cell F780 and F781

Code no.	Dimensions in mm			Nominal volume flow		Weight in kg approx.
	B	H	T	in l/s	in m <sup>3</sup> /h	
<b>Construction W</b>						
91	305	610	292	310	1100	9.0
92	610	610	292	610	2200	15.0
35	305	610	292	415	1500	9.0
61	610	610	292	830	3000	15.0
76	762	610	292	1040	3750	20.0
<b>Construction M and E</b>						
91	305	610	292	345	1250	9.0
92	610	610	292	695	2500	15.0
35	305	610	292	470	1700	9.5
61	610	610	292	945	3400	15.0
76	762	610	292	1180	4250	20.0

### Dimensions: Code nos. 35, 61 and 76

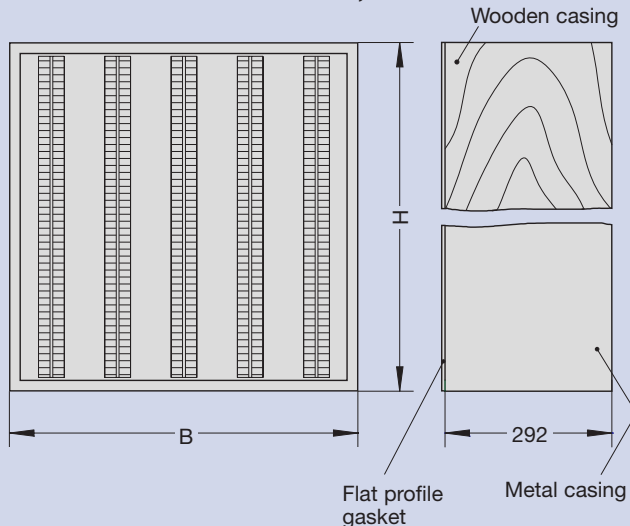

### Dimensions: Minipleat filter cell F781 with large filter area (Code letter S)

Code no.	Dimensions in mm (without seal)			Nominal volume flow		Weight in kg approx.
	B	H	T	in l/s	in m <sup>3</sup> /h	
<b>Construction M and E</b>						
35	305	610	292	555	2000	9.5
61	610	610	292	1110	4000	15.0
76	762	610	292	1390	5000	20.0

Dimensional tolerance + 0 mm  
 - 1 mm

All volume flow figures in l/s have been rounded off, then converted to m<sup>3</sup>/h.  
 Weights are net excluding packaging;  
 Weight of packaging per unit approx. 0.5 kg.

# Testing - Specification Text

## Testing of particulate filters

### EN 779: Particulate air filters for general room air-conditioning

This Norm is concerned with the performance testing of particulate air filters with an Efficiency up to 98% against atmospheric dust (see leaflet : F 0 / 2 / EN / ).

The particulate filters are divided into filter grades F5 to F9 according to their test results to EN 779.

Tests are carried out in accordance with an oil mist test to EN 1822, a local scan test to verify the filters are free from leaks.

Trox offers the following:

**F781:** Filter panels individually type-tested for leaks:

**0** = Standard with oil mist test  
or at increased price:

**E** = Scan test (particle counting)

## Testing of high efficiency particulate filters

### EN 1822: High efficiency particulate filters (HEPA and ULPA)

This new European Norm testing procedure is based on particle counting using a liquid test aerosol of varying particle sizes.

The filters are rated by filter class according to extract efficiency or penetration.

## Leak-test

## Specification Text

Item	Qty.	Description
		<p><b>Trox Minipleat Filter Cells F756, F757 and F759</b> consisting of: Casing of fibre board, galvanized sheet steel or stainless sheet steel; Filter media of high quality cellulose or glass fibre paper with textile thread spacers. The filter cells F756, F757 and 759 are packed in damage resistant cartons for transportation.</p> <p><b>Trox Minipleat Filter Cells F780 and F781</b> consisting of: Casing of fibre board, galvanized sheet steel or stainless sheet steel; Filter media of high quality moisture resistant glass fibre paper with textile spacers. Minipleat filter cell F781 is type tested for leaks by oil-mist test at factory. Minipleat filter cells F780 and F781 are packed in damage-resistant cartons for transportation.</p> <p><b>Technical data:</b> Filter class EN 779 _____ Average Efficiency _____ % Filter class to EN 1822 _____ Extraction efficiency to EN 1822 _____ % Dimensions (B x H x T) _____ mm Nominal volume flow _____ l/s (m<sup>3</sup>/h) Initial pressure differential _____ Pa Max. operating temperature _____ °C Max. relative humidity _____ % Net weight _____ kg Order no. _____ Manufacture: Trox</p>
		Price / Each