

# Cylindrical Attenuator

Type CD · CDP

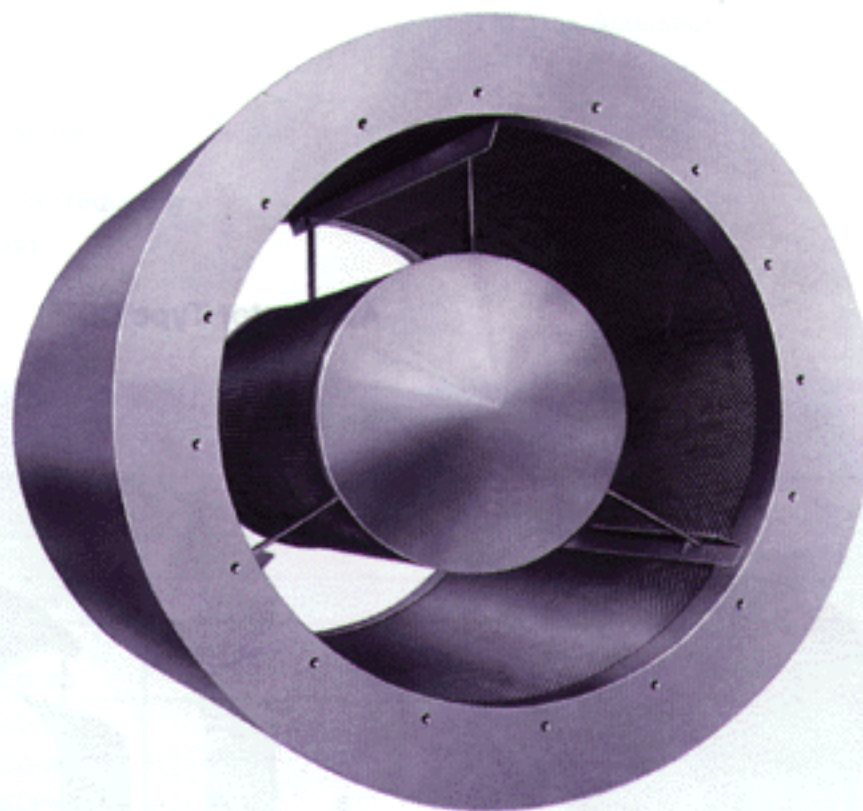

**TROX<sup>®</sup> TECHNIK**

Trox Brothers Limited  
Caxton Way  
GB-Thetford Norfolk IP24 3SQ

Telephone 0842 754545  
Telex 81442  
Telefax 0842 763051

# Contents · Description

---

Description _____	2	Acoustic and Aerodynamic Performance _____	5
Construction · Dimensions _____	3	Nomenclature _____	5
Alternative Constructions · Dimensions · Weights _____	4	Order Details _____	6

**Attenuator Type CD**

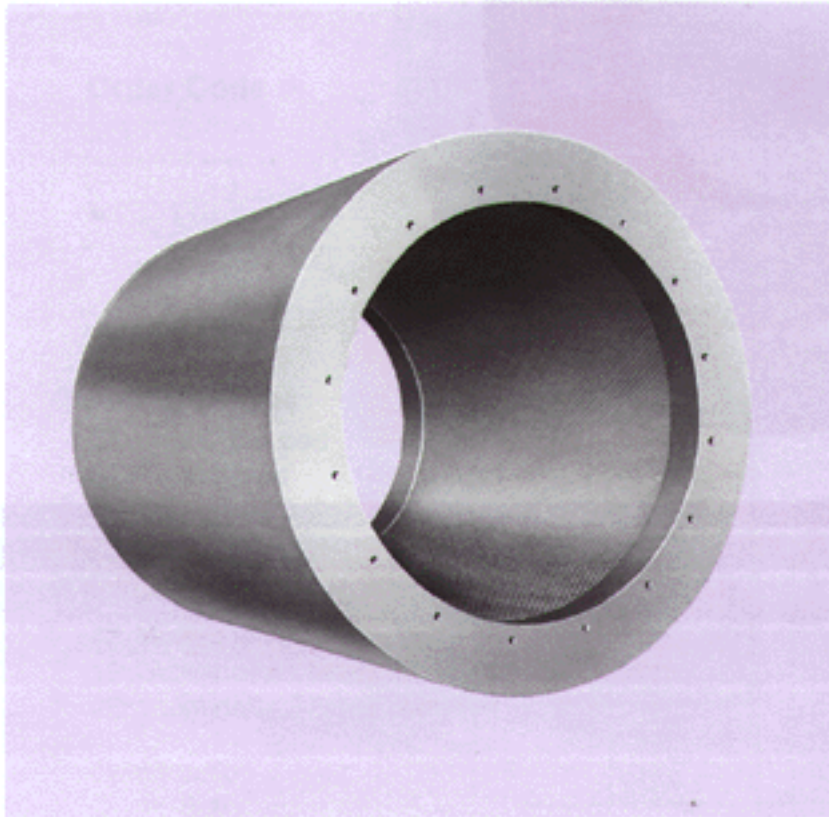

**Attenuator Type CDP**

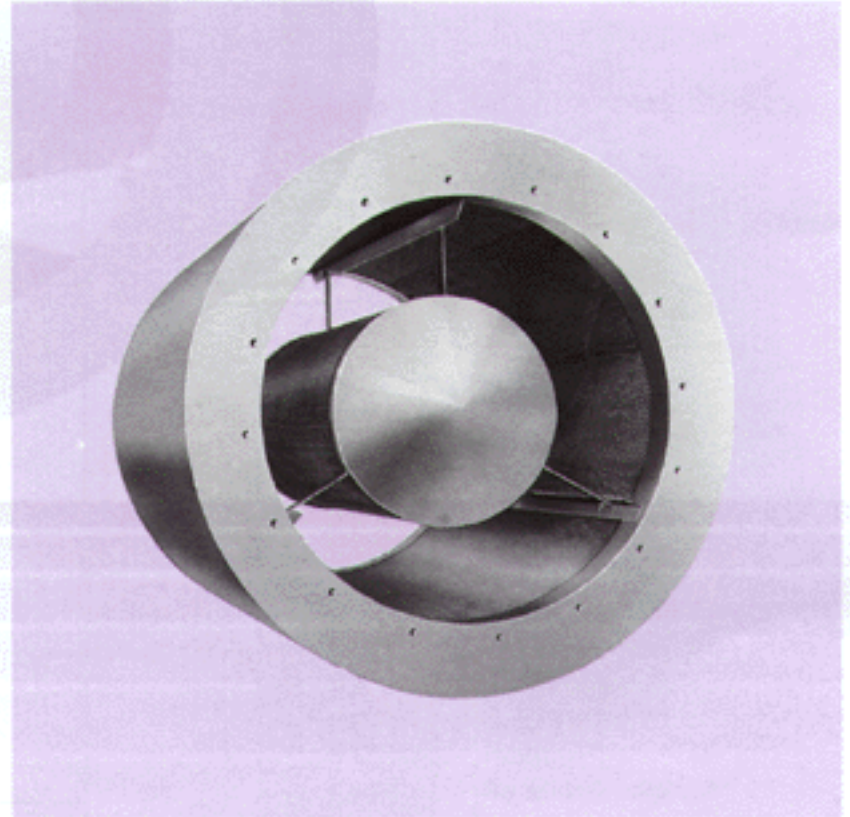

Trox standard cylindrical attenuators, Types CD and CDP are available in a wide range of sizes in two standard lengths for both 'on-fan' and 'in-duct' applications. Alternative metric and imperial sizes and acoustic lengths are available.

Type CD is a 'straight through' design offering good acoustic performance and negligible pressure loss. For higher performance, Type CDP incorporates an aerodynamically efficient concentric acoustic pod.

## Cylindrical Attenuator Type CD · CDP

### Construction

Standard Type CD and podded Type CDP attenuators are available in a size range based upon ISO standards. Two lengths are catalogued, nominally equivalent to one times and two times inside duct diameter with increased lengths available where higher acoustic performance is required. Alternative sizes and end connection types can be provided.

Standard attenuator casings are manufactured from galvanised sheet metal to BS 2989 Grade Z2 G275. Casings are

constructed with grooved seams with a mastic sealant; casing thickness complies with DW 142 Class B ductwork code. End plates contain threaded inserts M6-M10 as standard depending upon attenuator size. The attenuators contain acoustic infill which complies with Class O Building Regulations. The infill has a glass cloth facing and is contained behind perforated metal; this dual protection prevents damage and fibre erosion up to 30 m/s airway velocity. Where fitted, the acoustic pod has coned ends to minimise air pressure loss and regenerated noise.

Type CDP

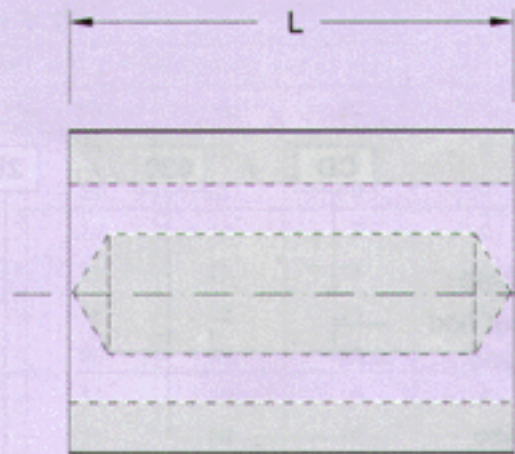
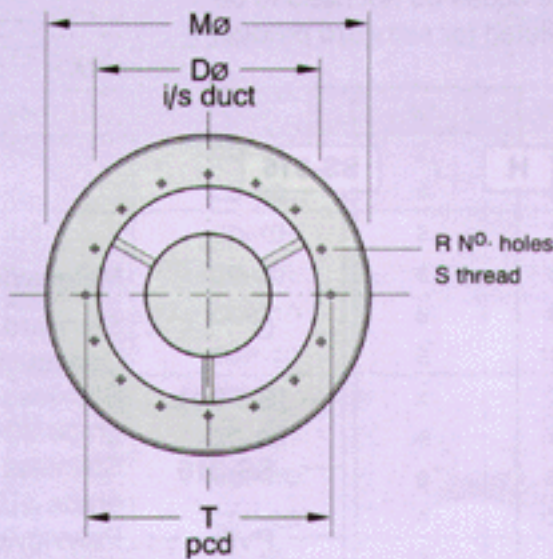

Type CD

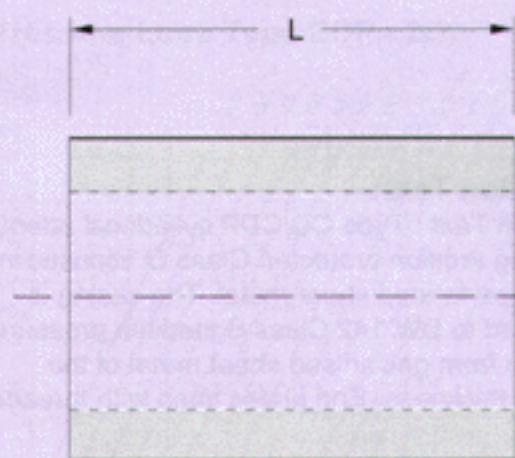
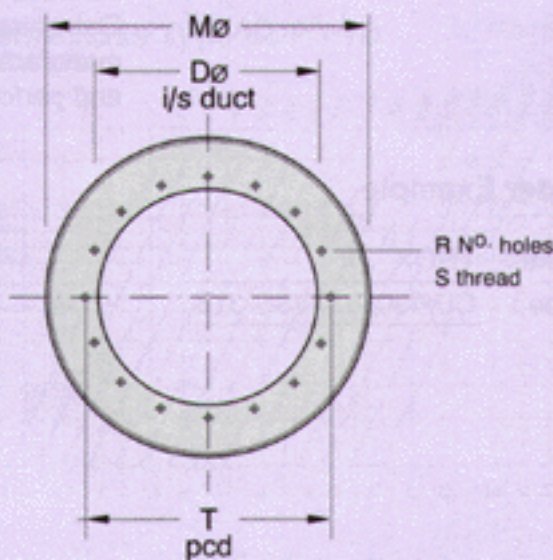

# Alternative Constructions · Dimensions · Weights

## Alternative Construction

### Type CDH/CDPH

As for standard types but with increased casing thickness to comply with ductwork codes DW 142 Class C or D.

### Type CDM/CDPM

As for standard types but the acoustic infill is enveloped in a Melinex polyester film.

## Sectionalised Construction

Attenuators would normally be supplied split on length when the "L" dimension exceeds 2000mm, for site assembly by others. Coupling angles are supplied.

Unit size	Dimensions							Weights kg			
	D ∅	M ∅	L 1D	L 2D	T pcd	R N <sup>o</sup> . holes	S Thread size	CD -1D	CD -2D	CDP -1D	CDP -2D
250	256	456	250	500	286	6	M6	9	13	-	-
315	322	522	300	600	356	8	M8	11	15	14	20
355	361	561	350	700	395	8	M8	15	21	20	28
400	404	604	400	800	438	12	M8	18	27	26	36
450	453	653	450	900	487	12	M8	24	35	34	42
500	507	707	500	1000	541	12	M8	29	41	41	57
560	564	764	550	1100	605	16	M10	35	50	50	70
630	638	838	600	1200	674	16	M10	42	58	58	82
710	715	915	700	1400	751	16	M10	51	72	72	100
800	801	1001	800	1600	837	24	M10	58	82	79	111
900	898	1098	900	1800	934	24	M10	70	100	97	135
1000	1007	1207	1000	2000	1043	24	M10	95	135	120	185
1120	1130	1330	1100	2200	1174	24	M10	115	160	145	215
1250	1267	1467	1250	2500	1311	24	M10	130	180	165	240
1400	1421	1622	1400	2800	1465	24	M10	210	420	270	520
1600	1593	1793	1600	3200	1637	32	M10	250	490	320	620

# Acoustic Performance - Nomenclature

## Performance

Attenuator performance is derived from tests meeting the requirements of BS 4718 : 1971.

Static Insertion Loss figures are given in the table.

Full regenerated noise data is available for Trox cylindrical attenuators, to enable Installed Insertion Loss to be calculated.

## Nomenclature

- L in mm : Length
- D in mm : Inside diameter
- V in l/s : Volume flow rate
- $\Delta p$  in Pa : Pressure loss
- $f_m$  in Hz : Octave centre frequency
- $D_e$  in dB : Insertion loss

Pressure loss data relates to pod type attenuators and assumes that the airflow to the attenuator is uniform over the face, in a duct to duct layout. Units installed in situations leading to poor inlet or discharge conditions could incur pressure drops higher than catalogued. Podless attenuators have a pressure loss similar to an equivalent length of ductwork.

For insertion loss data for Melinex faced attenuators - refer to Trox Acoustics.

Attenuator		Insertion Loss, $D_e$ in dB							
Size	Type	Octave Centre Frequency, $f_m$ in Hz							
		63	125	250	500	1k	2k	4k	8k
250	CD-1D	2	3	6	11	12	7	6	4
	CD-2D	4	5	10	21	22	13	10	8
315 355 400 450	CD-1D	2	3	6	11	12	7	6	4
	CD-2D	4	5	10	21	22	13	10	8
	CDP-1D	5	6	10	16	22	24	20	15
	CDP-2D	9	12	18	30	44	48	38	29
500 560 630 710 800 900	CD-1D	2	3	6	11	10	6	5	4
	CD-2D	4	5	10	21	20	10	9	6
	CDP-1D	5	6	10	16	22	23	17	12
	CDP-2D	9	12	18	30	44	45	33	24
1000 1120 1250 1400 1600	CD-1D	2	3	6	11	8	5	4	3
	CD-2D	4	5	10	21	16	9	8	5
	CDP-1D	5	6	10	16	22	22	15	11
	CDP-2D	9	12	18	30	44	42	29	21

Pressure Loss Type CDP - 1D

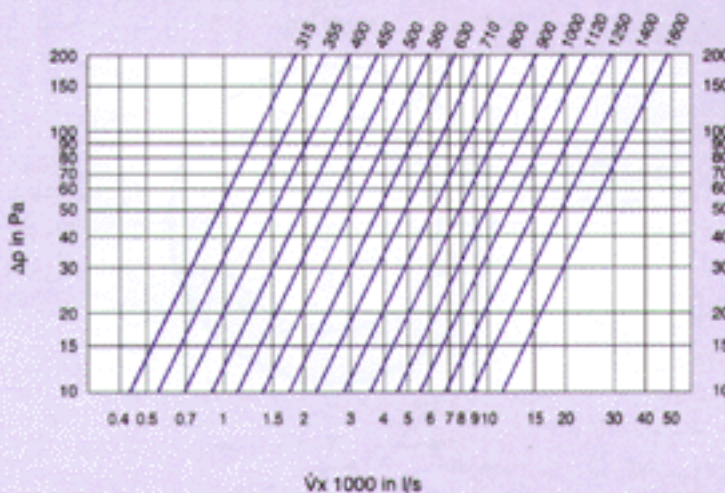

Pressure Loss Type CDP - 2D

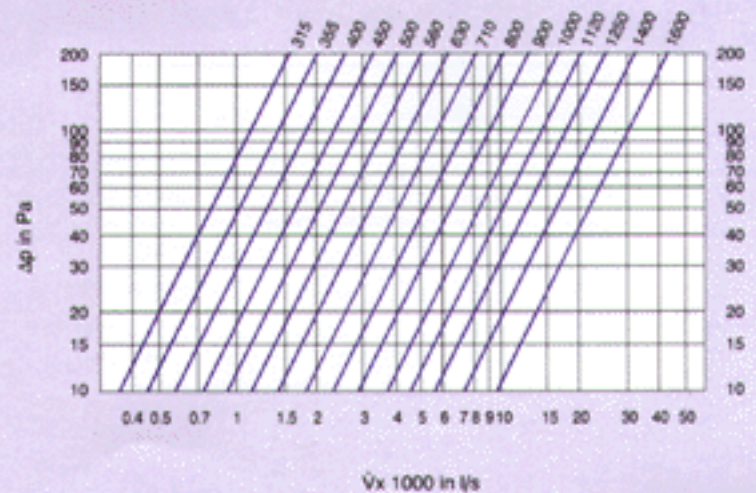

## Order Code

These codes do not need to be completed for standard product

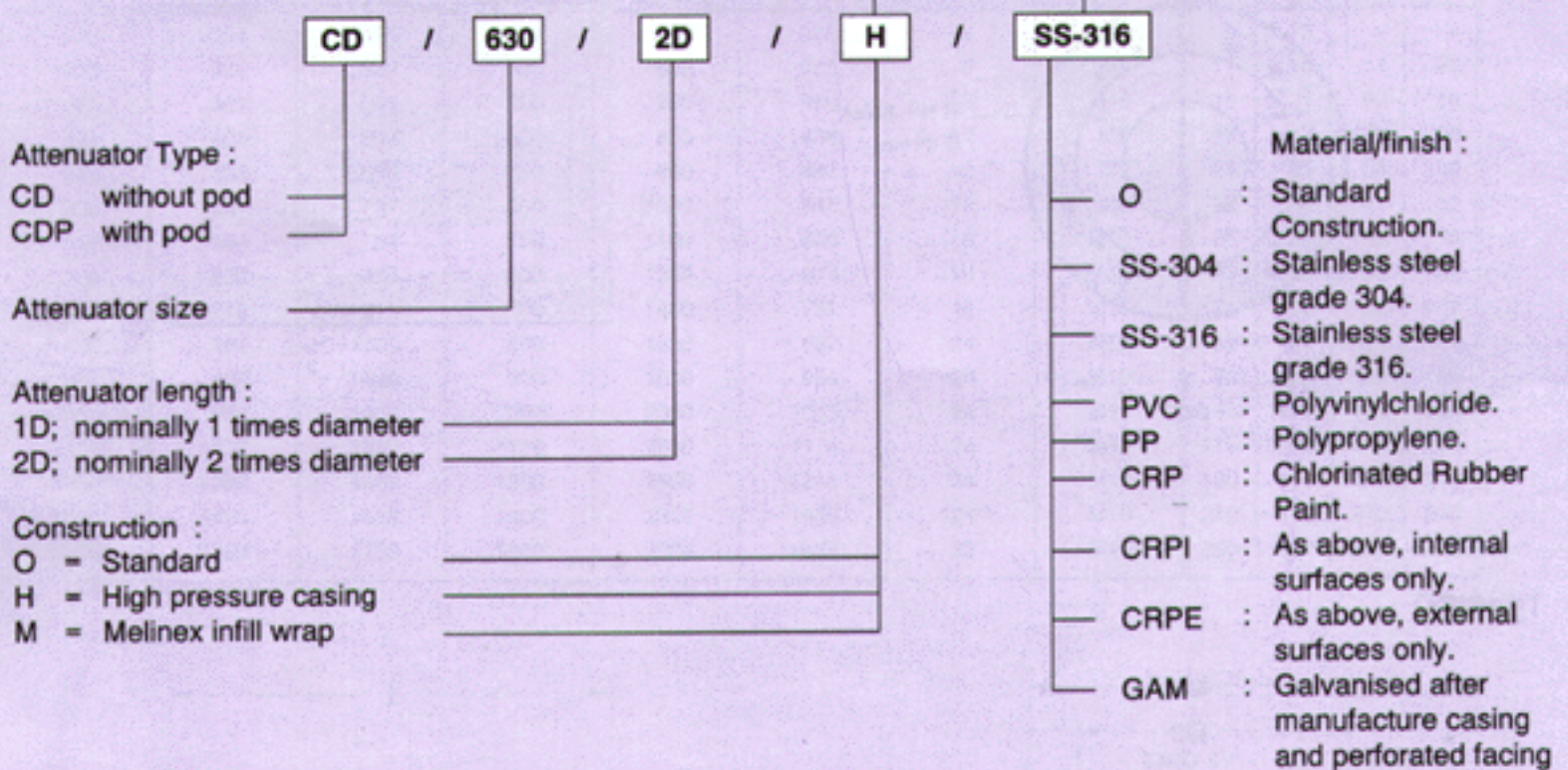

## Specification Text

Specification Text : Type CD/CDP cylindrical attenuator incorporating erosion protected Class O acoustic infill covered by perforated sheet metal. The casing is manufactured to DW 142 Class B medium pressure construction from galvanised sheet metal of the appropriate thickness. End plates fitted with threaded nut inserts.

## Order Example

Make : TROX  
 Type : CD/630/2D/H/SS-316