

'Euroscan SMU'

Electro-Mechanical Silo Level Indicator

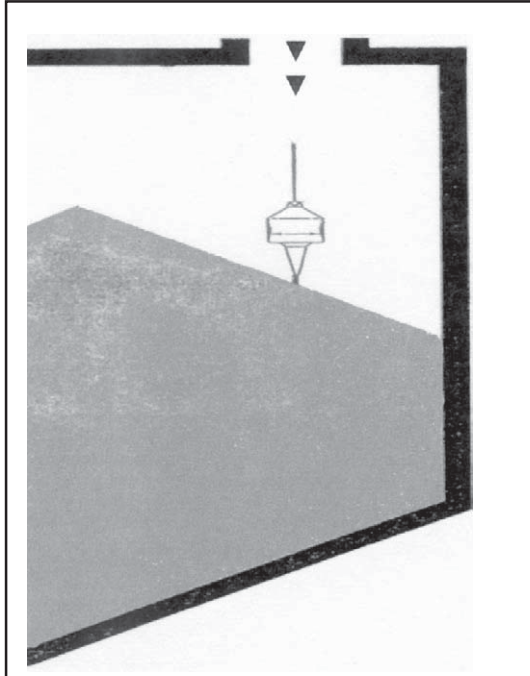

- ✓ Silos up to 45m
- ✓ Unaffected by heavy dusting
- ✓ Accurate
- ✓ Robust
- ✓ Reliable
- ✓ Easy to install
- ✓ Low Cost



Application

The 'Euroscan SMU' Electro-Mechanical Level Indicator has been designed to provide level measurement for powders and granular free-flowing solids in bulk storage silos up to 45m in height. The electro-mechanical principle of operation is unaffected by changes in product density, moisture or particle size.

The 'Euroscan SMU' silo level indicator is of robust construction and therefore suitable in most environments. It is simple to install and easy to maintain.

In its simplest form, the SMU is available as a 'stand-alone' unit providing a 4-20mA output (isolated self-powered current loop).

Excellence in Level Measurement



EUROGAUGE
... the level people



'Euroscan SMU'

Specification

Power Requirements	230Vac or 115Vac, 50/60Hz
Power Consumption	6VA continuous, 50 VA intermittent
Operating Temperature	-35°C to + 85°C
Internal Silo Temperature	85°C max.
Measurement Range	45m maximum
Measurement Rate	300mm/second (typical)
Accuracy	< 1% full scale (distance or level)
Repeatability	± 30 mm
Resolution	3mm
Mounting	see drawing below
Conduit Entry	2 x ¾" NPT
Cable	Stainless Steel
Output	4-20mA isolated, 500 ohm max loop resistance
Wiring Distance	max. 1000
H x W x L	655 x 216 x 290 mm
Weight	approx. 19kg
Enclosure/housing	Cast aluminium with Noryl cover
Plumb Bob Weight	approx. 0.95kg
Protection	IP66

We reserve the right to alter specifications or designs without notice.

Dimensions

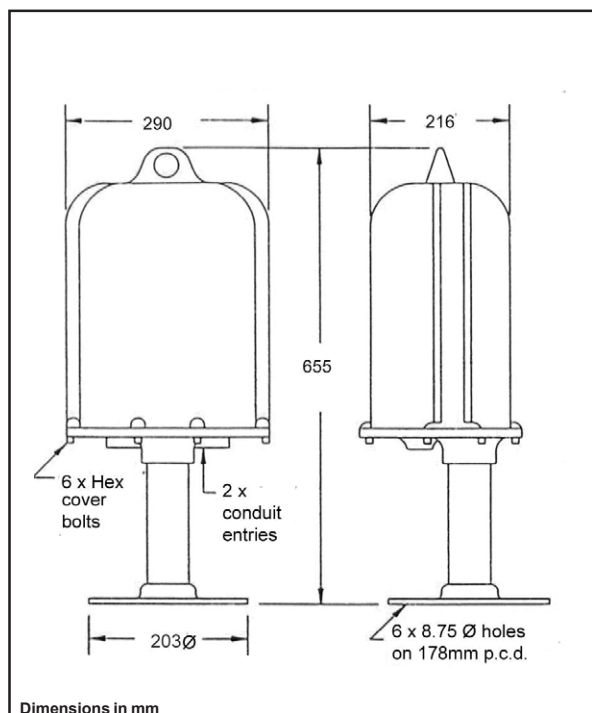

EUROGAUGE ... *the answer to All your Level Applications*

- **RADAR and MICROPULSE**
- **ULTRASONICS**
- **PRESSURE TRANSMITTERS**
- **VIBRATION SWITCHES**
- **CAPACITANCE**
- **Float Level Switches**
- **Conductivity**
- **Rotary Paddle and 'Plumb bob'**
- **Magnetostrictive**
- **Self-powered gauges**
- **Oil/water Alarms**
- **Leak Detectors**
- **Pressure and Temperature**



EUROGAUGE

... the level people

Afriso Eurogauge Ltd
Imberhorne Lane, East Grinstead
West Sussex. RH19 1RF
Tel: 01342 323641
Fax: 01342 315513
email: sales@eurogauge.co.uk
web site: www.eurogauge.co.uk