

# Decentralised window and façade ventilators with high acoustic performance

## Type FSL-B-60

In-flow and out-flow units for installation above and below a window



FassadenSystemLüftung  
GmbH & Co KG

# FSL

A company  
of the Trox group

FassadenSystemLüftung  
GmbH & Co KG  
Heinrich-Trox-Platz  
D-47506 Neukirchen-Vluyn

Telephone +49/28 45/2 02-7 11  
Telefax +49/28 45/2 02-2 25  
e-mail [fsl@trox.de](mailto:fsl@trox.de)  
[www.fsl-gmbh.com](http://www.fsl-gmbh.com)

# Contents · Description

Description	2
Construction · Installation proposals	3
Installation · Operation · Maintenance	4
Nomenclature · Technical data	5
Order details	6

**FSL-B-60 – View of internal face**



The type FSL-B-60 is a façade ventilation unit incorporating noise control. It provides supply or extract air for individual rooms or can be applied to complete buildings. This type of unit is integrated into the façade/external wall and provides a non fan-powered ventilation into or out of the internal space using the most direct route.

The unit consists of a casing which is internally lined with thermal/acoustic material. The external casing between the front and rear extrusions is from a flame retardant rigid board (material rating B1). This ensures adequate unit stability whilst providing a thermal break in the construction between front and rear. Units can be installed under a sill, or as the sill, at high level, or as part of a window head detail, vertically at the side of a window or integrated appropriately into curtain walling. The external face aluminium extrusion incorporates an insect screen.

Units can be used individually as in-flow or out-flow units depending on the inside/outside pressure difference.

**FSL-B-60 – View of external face**

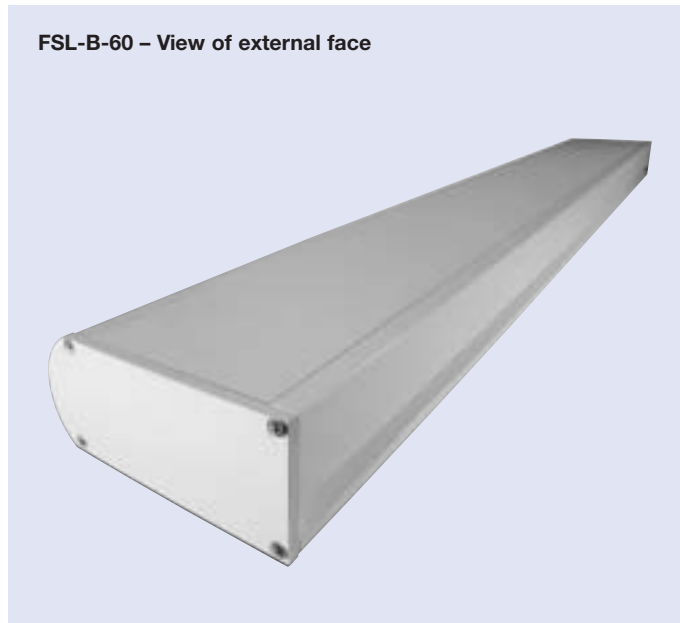

The units have an overall height of 60 mm and are variable in depth and width between 140 to 600 mm (lower depths on request) and 200 to 3000 mm respectively (see construction page 3). Thus they can be ideally matched to the structural situation. The length of the control cylinder is also variable from 200 to 1200 mm. For functionality and stability reasons, the cylinder length is limited. If the total width of the unit is greater than the cylinder length, then the position of the cylinder within the overall width can be selected.

The internal and/or external aluminium extrusions are anodised or available in a range of RAL paint finishes.

The ventilation units are lined with mineral wool enclosed in a fibreglass mesh for noise and thermal insulation. Materials used are erosion resistant to up to air velocities of 20 m/s and comply with the hygiene requirements of VDI 6022.

The discharge characteristics can be altered by rotating the control cylinder. The different adjustment options are shown on page 4.

# Construction · Installation proposals

FSL-B-60 components:

- ① Casing
- ② Control cylinder
- ③ Weather protection extrusion including insect mesh
- ④ Active section (air flow section)
- ⑤ Non active section

**FSL-B-60 completely active**

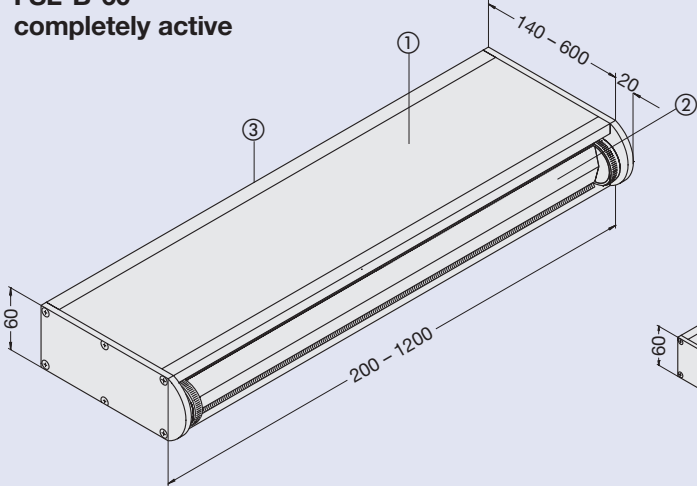

**FSL-B-60 partially active**

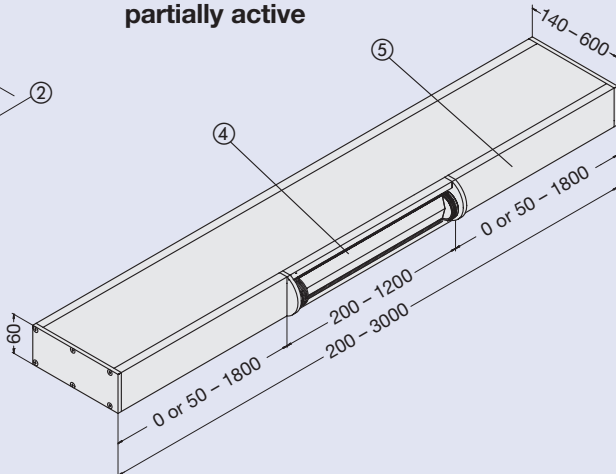

**Construction sectional details**  
visible installation at sill/ceiling · **SEB**

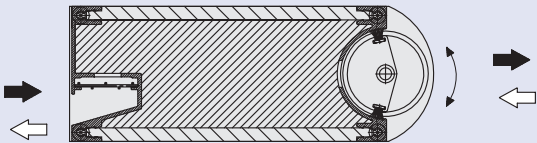

**Installation proposals**

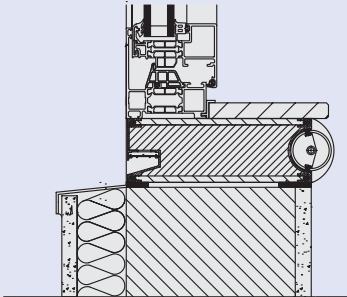

without external profile, installation at sill/ceiling · **OAB**

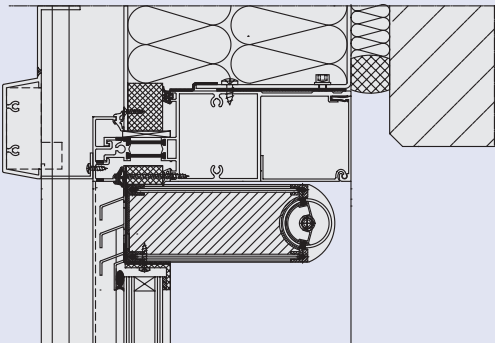
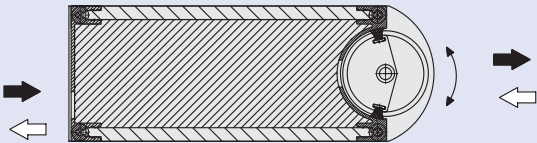

## Installation

There are various possibilities for the integration and installation of the unit type FSL-B-60 into the façade. The basic version of the unit is supplied without fixings.

When installing in a window transom detail or curtain walling purpose designed fixing components can be supplied as optional items. These can be factory fitted to simplify site installation.

Fixing details available on request.

## Operation

The adjustment of the air discharge is by means of the control cylinder. The corrugated face of the control cylinder end caps provides a simple adjustment.

The direction of air discharge can be arranged to suit the application and the installation location.

In the closed position, brush seals prevent unwanted air flows (fig. 1).

The control cylinder can direct the air upwards and downwards into the room by turning the cylinder through 180 degrees. This provides a diffused air discharge (fig. 2).

In addition the fresh air can be directed downwards or upwards into the room (fig. 3/4).

## Maintenance

To clean the control cylinder and the air duct, first remove the cylinder. To do this, gently push the cylinder to the left or right and simultaneously pull forward (fig. 5). To refit the cylinder, reverse the process. In order to refit the control cylinder the spring loaded ball at the end of the cylinder must be engaged in the hole in the side plate.

For cleaning the air duct, it is recommended to blow through with compressed air or suck out with a vacuum cleaner.

By using compressed air, the insect screen in the external louvre can also be cleaned of debris. Use suitable cleaning agents (non abrasive material) to remove the dirt particles on the casing and the cylinder.

Fig. 5

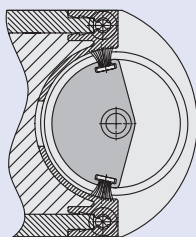
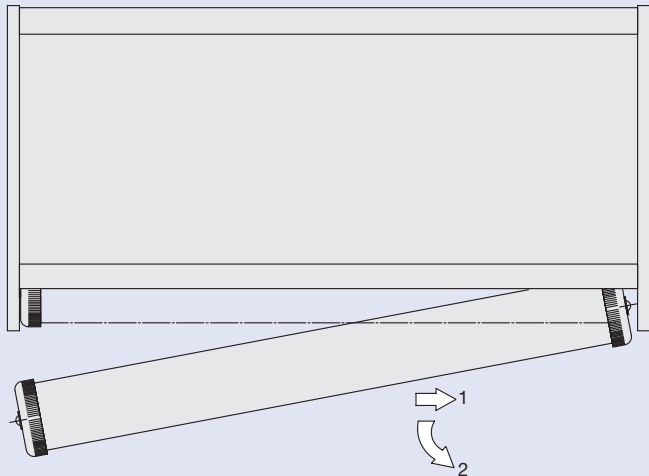

Fig. 1  
Air outlet closed

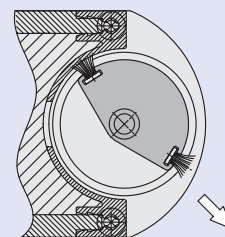

Fig. 3  
Discharge downwards

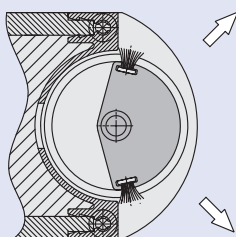

Fig. 2  
Diffused discharge

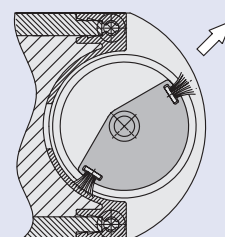

Fig. 4  
Discharge upwards

## Nomenclature

H	in mm:	Unit height
T	in mm:	Unit depth
B	in mm:	Unit width
$\dot{V}$	in $\text{m}^3/\text{h}$ · per m:	Volume flow rate per m active width
$\Delta p$	in Pa:	Pressure difference between the room and outside
$D_{n, e, w (g)}$	in dB:	Evaluated regulation noise-level difference with closed unit
$D_{n, e, w (o)}$	in dB:	Evaluated regulation noise-level difference with open unit
U	in $\frac{\text{W}}{\text{m}^2 \cdot \text{K}}$ :	Thermal transfer coefficient (U-value)
$A_{\text{FR}}$	in $\text{mm}^2/\text{m}$ :	Free cross-sectional area per m active width
m	in kg/m:	Weight (mass) of the unit per m width

## Technical data

H	60
T	140 – 600
B	200 – 3000
$D_{n, e, w (g)} / D_{n, e, w (o)}$ for T = 140 mm	40 / 35
$D_{n, e, w (g)} / D_{n, e, w (o)}$ for T = 170 mm	44 / 39
$D_{n, e, w (g)} / D_{n, e, w (o)}$ for T = 220 mm	47 / 42
U (for T = 140 mm)	1.57
$A_{\text{FR}}$	approx. 8000
m (for T = 170 / 220 mm)	approx. 5 / 6

### Example:

$\Delta p = 12 \text{ Pa}$   
 $\dot{V} = 50 \text{ m}^3/\text{h} \cdot \text{per m}$

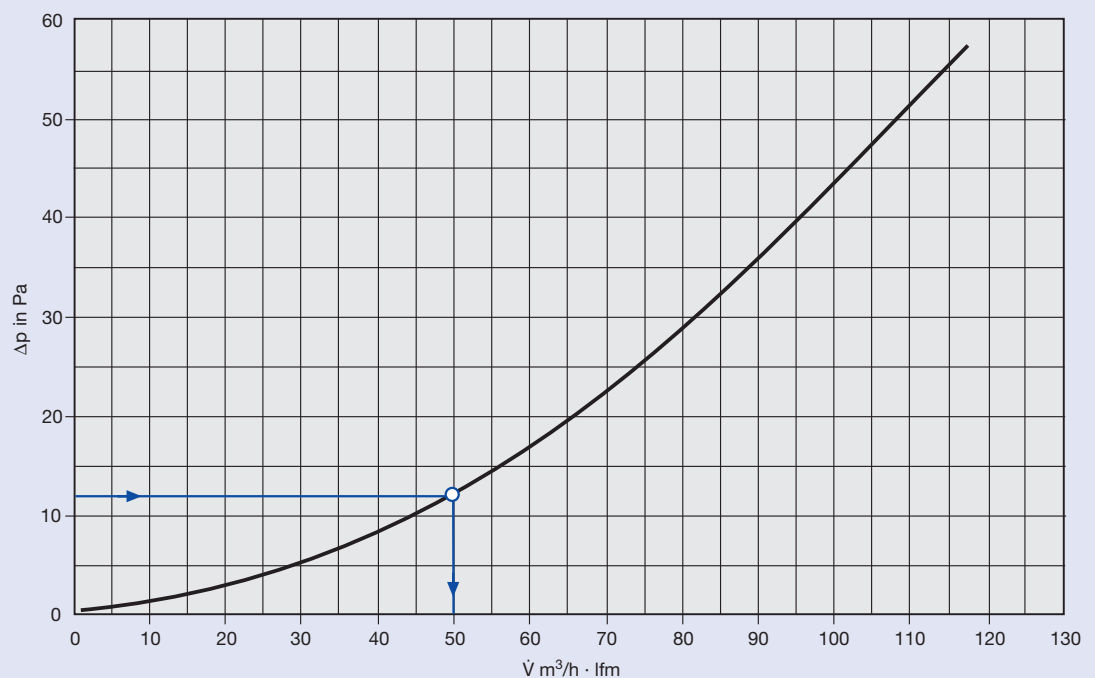

# Order Details



## As in-flow or out-flow units without a fan

- Various installation options, e.g. under a sill, or as the sill, at high level, or as part of a window head detail, vertically at the side of a window or integrated appropriately into curtain walling.
- Main casing from flame retardant rigid board (material rating B1, flame resistant to DIN 4102, part 1) the board provides a thermal break between front and rear casing.
- Acoustic lining with fiberglass mesh covered mineral wool (material rating A, flame resistant to DIN 4102, part 1).
- Design and materials comply with the hygiene standards of VDI 6022.
- Depending upon the position of the air control cylinder, the supply air can be a diffuse discharge or directed in specific directions.
- Max. length of the air control cylinder: 1200 mm, the remaining section is non active.
- The air control cylinder can be quickly removed and simply cleaned.
- Internal and external extrusions and the air control cylinder in aluminium sections, finish RAL 9010.

- Outside face with recessed opening incorporating insect screen.
- Air flow rate dependent on the pressure difference existing on site (approx. 50 m³/h with 12 Pa and 1 m of active unit width).
- Free cross-sectional area approx. 8000 mm² per 1 m of active unit width.
- Standard sound level difference with a depth of 220 mm and air outlet shut  $D_{n,e,w} = 47$  dB (open  $D_{n,e,w} = 42$  dB).

### Optional with:

- Paint finish in standard RAL colours or natural anodised finish.
- Factory fitted fixing components for integration into the façade or curtain walling.
- Dual-colour finish (internal / external elements).

Dimensions: Height: 60 mm  
 Depth: 140 – 600 mm  
 Width: 200 – 3000 mm  
 Active Width: 200 – 1200 mm

## Order code

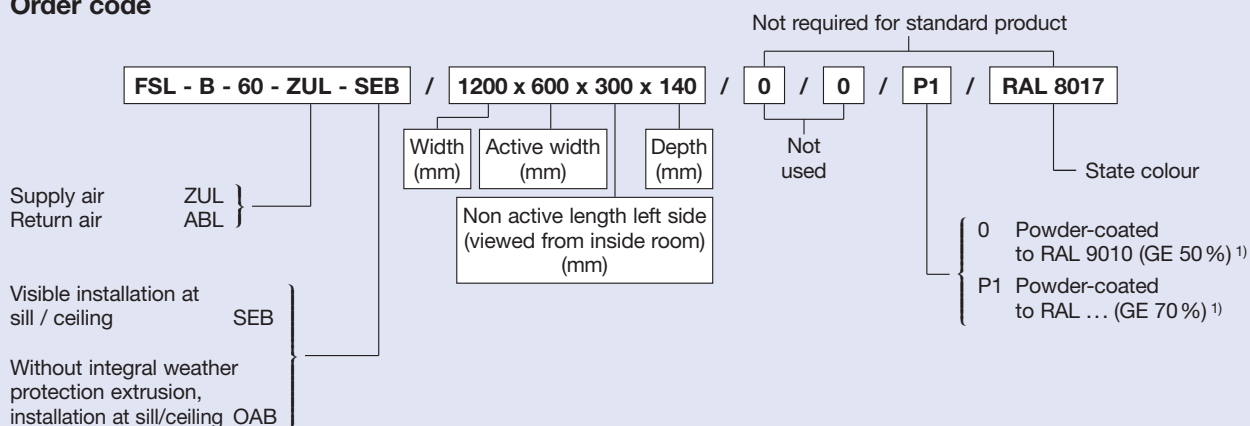

1) GE = Gloss level

## Order example

Make: TROX  
 Type: FSL-B-60-ZUL-SEB / 1200x600x300x140 / P1 / RAL 8017