



ECOVENT *Plus*

Energy saving air handling units

- *100% fresh air and exhaust with up to 70% heating or cooling recovery.*
- *Sophisticated fitted controls package for maximum energy saving.*



Eco-friendly products



Ecovent Plus is a comprehensive range of ventilation and heat recovery units providing fresh air via a plate heat exchanger, which extracts the heat from the exhaust air.

- Units available flat or stacked, in plantroom or weatherproof construction.
- The recuperator has an efficiency of up to 70% and is maintenance free.
- Ecovent Plus units have no cross contamination of moisture, smells or fumes.
- Fans are fully vibration isolated within the case and no additional AV mounts or flexible connections are required.
- All electrical items prewired to an external terminal box on Ecovent Plus sizes 1-4, and optional on belt driven units sizes 5-8.
- Filters to inlet and exhaust intakes.
- Step controlled electric heater or hot water heater.



Further design options

- Fitted control system.
- Twin extract fans with autochangeover system.
- Heavyweight panel infill to further reduce noise breakout.
- Fitted cooling or heat pump coils. It may be necessary to make the unit wider or go to the next size due to face velocity and air pressure drop through coil.
- Increased corrosion protection for coastal, swimming pool or food processing applications. Internal powder coat paint finish or stainless steel panelling available.
- Special colour - advise BS or RAL number.
- High humidity in extract air will produce condensation within the heat exchanger in swimming pools, shower rooms etc., but not in general ventilation systems. For such systems specify a drain pan to recuperator exhaust. This will have a connection for drainage which should be trapped.
- Larger units can be supplied - refer to MAX air handler leaflet.
- Plate heat exchangers in housing with filter only available - see page 19.

Fitted Control System

A new generation of microprocessor controls have been developed by VES to optimise the heating/cooling recovery of the ECOVENT Plus range.

A remote wall mounting controller is supplied for temperature adjustment, time clock programming, and required set point temperature display. The controller has a 4 wire low voltage screened cable connection to panel, and is designed to fit onto a single gang wall box or surface mounted.



Remote room controller

The air temperature is monitored using sensors which constantly check the fresh air intake, supply air duct and extract or room temperature. From this the face and bypass damper on the plate heat exchanger is automatically adjusted for heat recovery, free cooling or cooling recovery.

Should a DX heat pump coil be fitted an additional sensor will be located after the plate heat exchanger to ensure an air on temperature of at least 12°C onto the heat pump coil is provided in heating mode. In this situation a hot water or electric heater must be fitted between the plate heat exchanger and the DX coil.

Control panels can be fitted and prewired or supplied for remote location.



The control panel also has the following standard features:

- Supply and extract fan starters.
- Fully modulating hot water heating control by 0-10 volt signal, with frost stat supplied, or -
- Up to nine steps of electric heater control.

Further options:

- Cooling or heat pump control.
- Fan speed control.
- Two speed fan control for night set back operation.
- Autochangeover for twin extract fans using the AF500 autochangeover panel.
- BMS volt free contacts for any number of signals.
- Anti-condensation heater in weatherproof panels.

A super slim unit of single skin construction with thermal lining, suitable for top or bottom access, and internal or weatherproof location. The unit contains plate heat exchanger, filters to supply and extract intake, centrifugal fans. There is no face and bypass damper to heat exchanger in the Ecovent 1, and should a heater be required this can be supplied to match unit outlet.

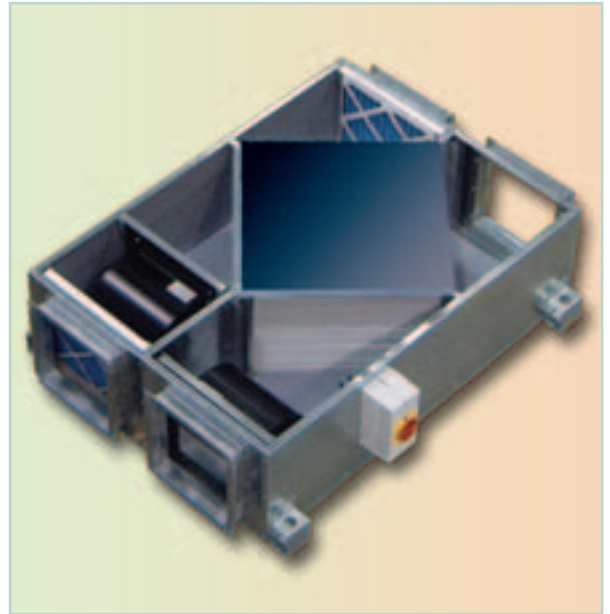
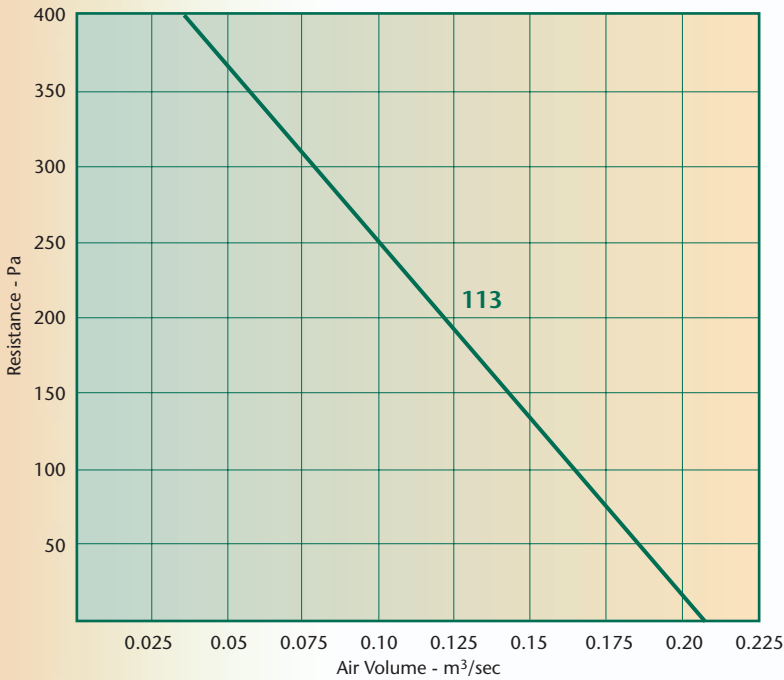

Specification:

Supply and extract fans

- Power 310 watts
- 230 volt 1 phase 50 Hz
- FLC 1.26 amps
- Fans prewired to external isolator.
- Fans are speed controllable.

Case

- Single skinned, galvanised sheet steel, thermally lined with aluminium foil faced rigid polyurethane foam.
- Available top or bottom access.
- Weatherproof unit has top access, air intake and exhaust outlet louvres, pitched roof and mounting feet, finished in light grey powder coat to BS00A05.

Filters

- Pleated, synthetic, disposable cell
- Grade G4 (EU4)

Dimensions

- Internal units page 10.
- Weatherproof units page 11.

Noise Levels

ECOVENT UNIT MODEL	Sound Spectrum, in duct, dB ref 10 ⁻¹² w PWL Centre Frequency - Hz								Casing Noise Breakout		*Silencer to NR35/40	Silencer Resistance APD @ Vol.	
	63	125	250	500	1k	2k	4k	8k	NR @1m	NR @3m		Pa	m³/sec
113	50	59	62	60	64	63	62	57	40	35	ECA100/1200/STD	12	0.15

*Silencers suitable for connection directly onto unit.

This unit offers a comprehensive range of components and layouts. The plate heat exchanger has a face and bypass damper, filters to supply and extract intake, hot water or electric heater, internal or weatherproof case in flat or stacked configuration.

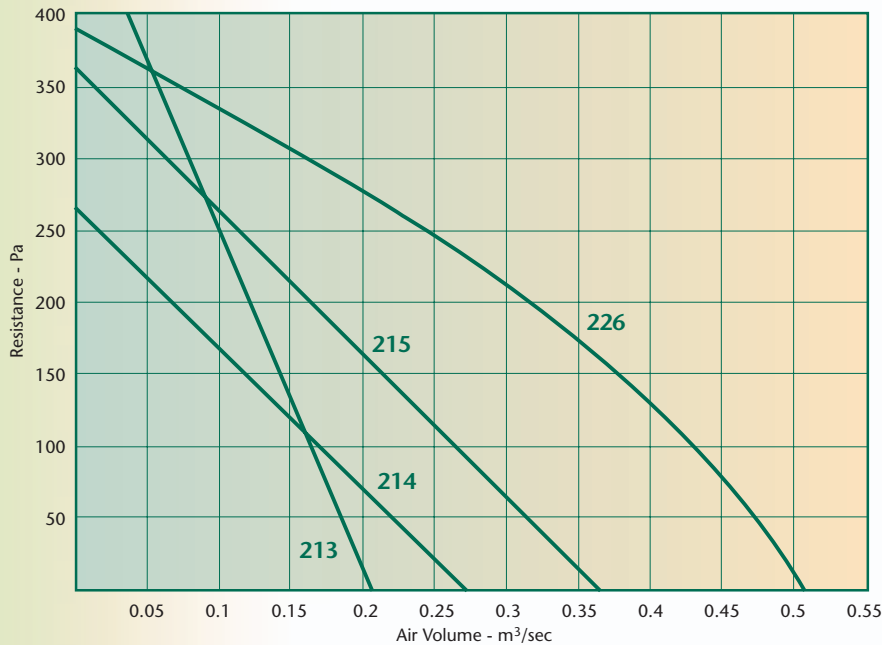

Specification:

Supply and Extract fans	Model 213	Model 214	Model 215	Model 226
Power, watts	310	460	675	1150
FLC, amps	1.26	2.1	3.15	5.10
Current	230 volt 1 phase 50 Hz			
Fans have automatic high temperature cut out protection, and are speed controllable.				

Heater - Step controlled electric heater or standard hot water heater, designed for LPHW 82/71°C with EAT -1°C, LAT 25°C. Coil construction is of copper tubes with aluminium fins and BSP external pipe connections.

Face and bypass damper fitted onto exhaust side of plate heat exchanger, with 230 volt 2 position actuator. All electric components prewired to terminal box or control panel if fitted.

Filters - Pleated, synthetic, disposable cell grade G4 (EU4).

Case - Single skinned, galvanised sheet steel, thermally lined with aluminium foil faced polyurethane foam. Weatherproof units supplied with air intake and exhaust cowls, pitched roof and channel base, finished in light grey powder coat to BS00A05.

Dimensions

Internal units page 12, weatherproof units page 13.

Noise Levels

ECOVENT UNIT MODEL	Sound Spectrum, in duct, dB ref 10 ⁻¹² w PWL Centre Frequency - Hz								Casing Noise Breakout		*Silencer to NR35/40	Silencer Resistance APD @ Vol.	
	63	125	250	500	1k	2k	4k	8k	NR @1m	NR @3m		Pa	m ³ /sec
213	50	59	62	60	64	63	62	57	40	35	ECA200/1200/STD	3	0.15
214	44	52	60	60	53	60	58	55	40	35	ECA200/1200/STD	5	0.20
215	58	72	71	70	75	75	73	71	45	40	ECA200/1200/STD	10	0.30
226	64	75	77	73	79	80	76	70	50	45	ECA200/1200/STD	25	0.45

*Silencers suitable for connection direct to unit.

These units offer a comprehensive range of components and layouts. The plate heat exchanger has a face and bypass damper, filters to supply and extract intake, hot water or electric heater, internal or weatherproof case in flat or stacked configuration.

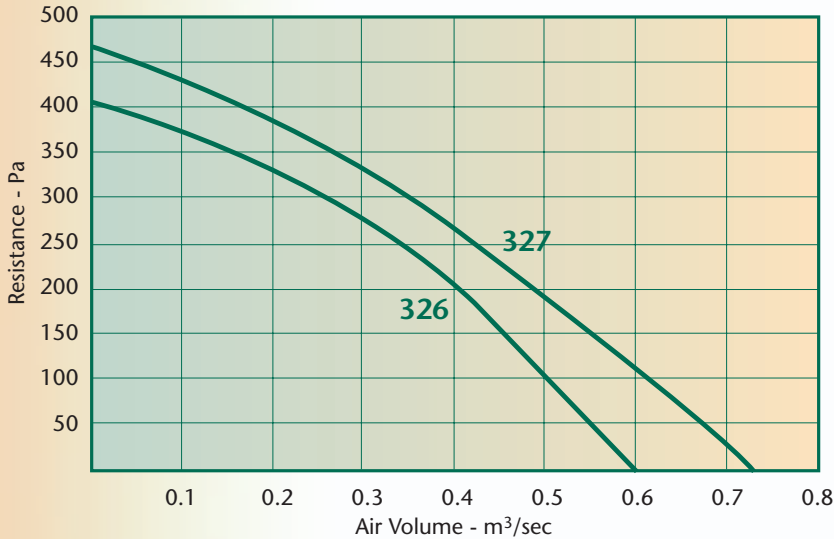

Specification:

Supply and Extract fans	Model 326	Model 327
Power, watts	1150	1650
FLC, amps	5.1	7.2
Current	230 volt 1 phase 50 Hz	230 volt 1 phase 50 Hz

Fans have automatic high temperature cut out protection, and are speed controllable.

Heater - Step controlled electric heater or standard hot water heater, designed for LPHW 82/71°C with EAT -1°C, LAT 25°C. Coil construction is of copper tubes with aluminium fins and BSP external pipe connections.

Face and bypass damper fitted onto exhaust side of plate heat exchanger, with 230 volt 2 position actuator. All electric components prewired to terminal box or control panel if fitted.

Filters

Pleated, synthetic, disposable cell grade G4 (EU4).

Case

25mm double skinned with tubular aluminium frame, and galvanised sheet steel panels with resin bonded mineral wool slab infill. Weatherproof units supplied with air intake and exhaust cowls, pitched roof and channel base, finished in light grey powder coat to BS00A05.

Dimensions

Internal units page 14.

Weatherproof units page 15.

Noise Levels

ECOVENT UNIT MODEL	Sound Spectrum, in duct, dB ref 10 ⁻¹² w PWL Centre Frequency - Hz								Casing Noise Breakout		*Silencer to NR35/40	Silencer Resistance APD @ Vol.	
	63	125	250	500	1k	2k	4k	8k	NR @1m	NR @3m		Pa	m³/sec
326	64	75	77	73	79	80	76	70	45	40	ECA300/1200/STD	10	0.40
327	60	70	72	71	77	77	73	66	45	40	ECA300/1200/STD	25	0.60

*Silencers suitable for connection direct to unit.

This unit offers a comprehensive range of components and layouts. The plate heat exchanger has a face and bypass damper, filters to supply and extract intake, hot water or electric heater, internal or weatherproof case in flat or stacked configuration.

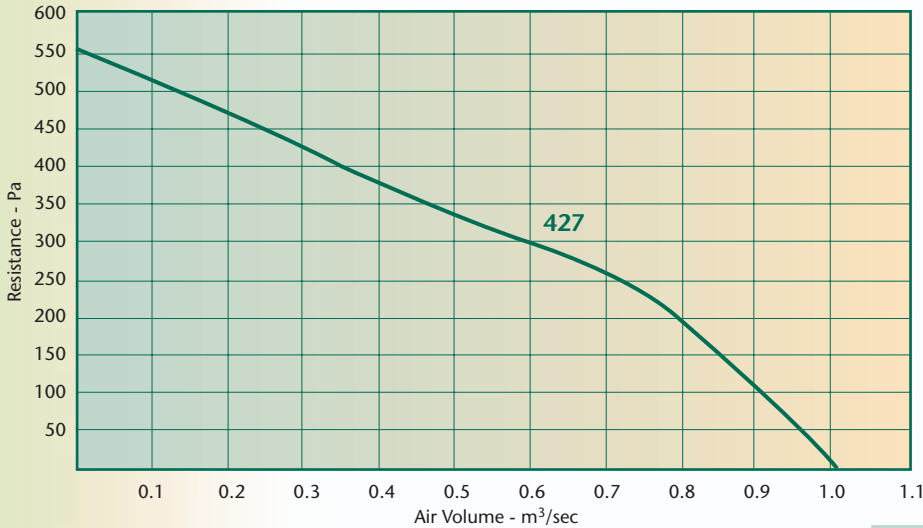

Specification:

Supply and Extract fans Model 427

Power, watts 1650
 FLC, amps 7.2
 Current 230 volt 1 phase 50 Hz
 Fans have automatic high temperature cut out protection, and are speed controllable.

Heater - Step controlled electric heater or standard hot water heater, designed for LPHW 82/71°C with EAT -1°C, LAT 25°C. Coil construction is of copper tubes with aluminium fins and BSP external pipe connections.

Face and bypass damper fitted onto exhaust side of plate heat exchanger, with 230 volt 2 position actuator. All electric components prewired to terminal box or control panel if fitted.



Filters

Pleated, synthetic, disposable cell grade G4 (EU4).

Case

25mm double skinned with tubular aluminium frame, and galvanised sheet steel panels with resin bonded mineral wool slab infill. Weatherproof units supplied with air intake and exhaust cowls, pitched roof and channel base, finished in light grey powder coat to BS00A05.

Dimensions

Internal units page 14. Weatherproof units page 15.

Noise Levels

ECOVENT UNIT MODEL	Sound Spectrum, in duct, dB ref 10 ⁻¹² w PWL Centre Frequency - Hz								Casing Noise Breakout		*Silencer to NR35/40	Silencer Resistance APD @ Vol.	
	63	125	250	500	1k	2k	4k	8k	NR @1m	NR @3m		Pa	m³/sec
427	60	70	72	71	77	77	73	66	45	40	ECA400/1200/STD	30	0.80

*Silencers suitable for connection direct to unit.



Size 5, 6, 7 & 8 - Selection Curves

These units contain belt driven centrifugal fans with the potential for components such as bag filters, cooling coils etc. The plate heat exchanger has a face and bypass damper, filters to supply and extract intake, hot water or electric heater, plantroom or weatherproof case in flat or stacked configuration.

For duties higher than 2.0m³/sec refer to the MAX air handling unit leaflet.

ECOVENT Plus 5

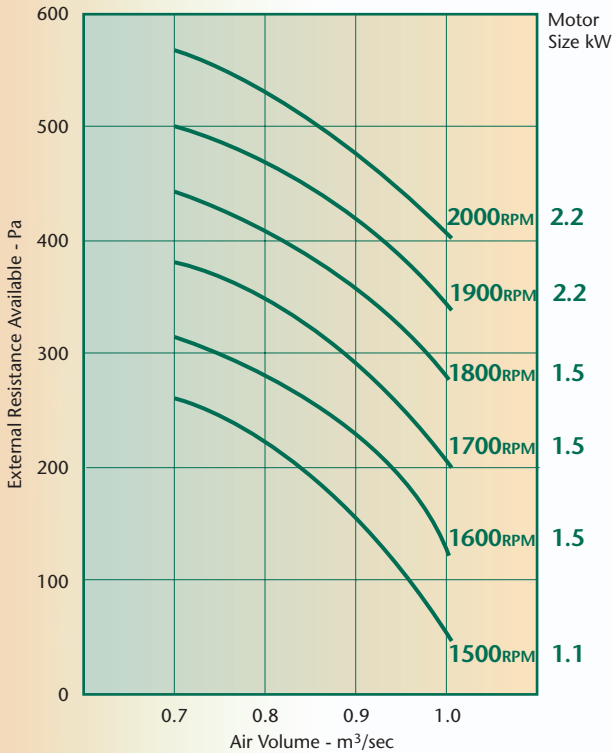

ECOVENT Plus 6

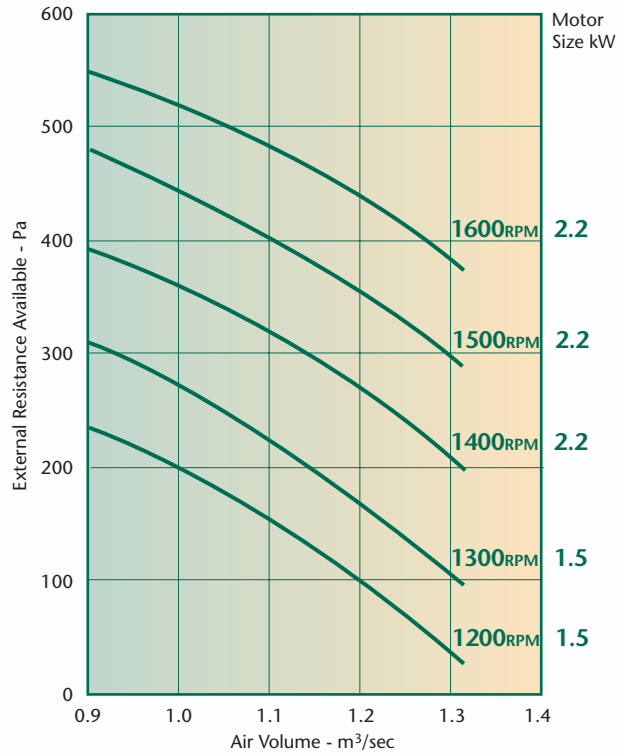

ECOVENT Plus 7

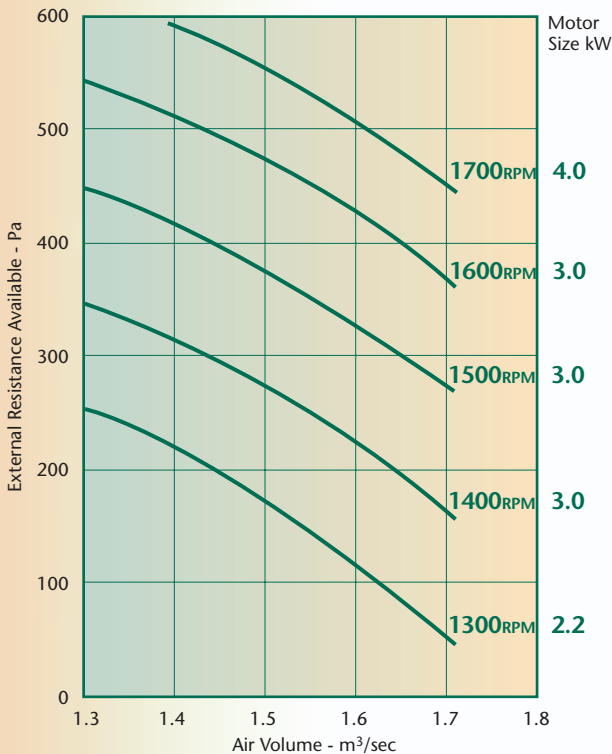

ECOVENT Plus 8

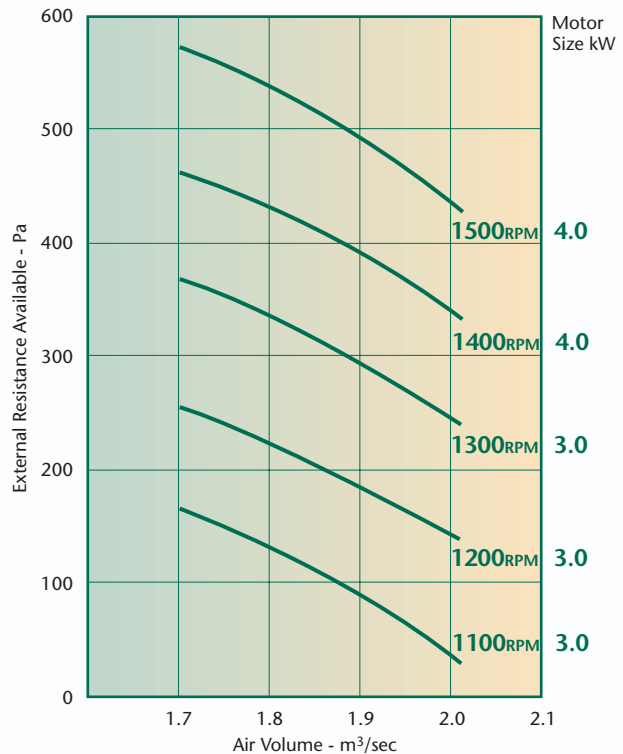



Size 5, 6, 7 & 8 - Specification

- Fans -** Forward curved double inlet centrifugal. The fan and motor assembly is fully vibration isolated from the case internally with A.V. mounts and flexible connections.
- Motors -** 230 volt 1 phase 50Hz motors available up to 2.2kw. All motors available for 400 volt 3 phase 50Hz. Two speed 3 phase motors and speed control with inverters available for all duties.
- Heater -** Electric, up to nine steps of control. Hot water, LPHW 82/71°C.
- Bypass Damper -** Face and bypass damper fitted onto exhaust side of plate heat exchanger, with 230 volt two position actuator.
- Case -** 25mm double skinned with tubular aluminium frame, and galvanised sheet steel panels with resin bonded mineral wool slab infill. Weatherproof unit finished light grey powder coat to BS00A05.
- Filters -** Pleated, synthetic, disposable cell, grade G4 (EU4).
- Dimensions -** Internal units page 16. Weatherproof units page 17.

Noise Levels and Silencers

ECOVENT PLUS UNIT MODEL	Sound Power Level, dB ref 10 ⁻¹² w PWL Centre Frequency-Hz								Casing Noise Breakout		Silencer to NR 35/40	Silencer Resistance APD @ Vol.	
	63	125	250	500	1K	2K	4K	8K	NR @1m	NR @3m		Pa	m ³ /sec
	ECO541-1500	77	76	73	71	70	68	64	60	45	40	VA4-60-60-120	23
541-1600	79	78	75	73	72	70	66	62	45	40	VA4-60-60-120	23	0.85
541-1700	80	79	76	74	73	71	67	63	50	45	VA4-60-60-120	26	0.90
541-1800	81	80	77	75	74	72	68	64	50	45	VA4-60-60-120	26	0.90
541-1900	81	80	77	75	74	72	68	64	50	45	VA4-60-60-120	28	0.95
541-2000	82	81	78	76	75	73	69	65	50	45	VA4-60-60-120	28	0.95
ECO642-1200	87	84	83	79	77	69	65	53	55	50	VA4-60-60-150	31	1.00
642-1300	89	86	85	81	79	71	67	55	55	50	VA4-60-60-150	38	1.10
642-1400	90	87	86	82	80	72	68	56	60	55	VA4-60-60-150	45	1.20
642-1500	93	90	89	85	83	75	71	59	60	55	VA4-60-60-150	53	1.30
642-1600	94	91	90	86	84	76	72	60	60	55	VA4-60-60-150	53	1.30
ECO743-1300	89	88	85	83	82	74	70	60	55	50	VA4-60-75-150	40	1.40
743-1400	91	90	87	85	84	76	72	62	60	55	VA4-60-75-150	46	1.50
743-1500	92	91	88	86	85	77	73	63	60	55	VA4-60-75-150	52	1.60
743-1600	93	92	89	87	86	78	74	64	60	55	VA4-60-75-150	58	1.70
743-1700	94	93	90	88	87	79	75	65	60	55	VA4-60-75-150	58	1.70
ECO844-1100	89	88	85	83	82	74	70	60	55	50	VA4-90-60-150	46	1.75
844-1200	90	89	86	84	83	75	71	61	60	55	VA4-90-60-150	52	1.85
844-1300	92	91	88	86	85	77	73	63	60	55	VA4-90-60-150	55	1.90
844-1400	94	93	90	88	87	79	75	65	65	60	VA4-90-60-150	58	1.95
844-1500	95	94	91	89	88	80	76	66	65	60	VA4-90-60-150	61	2.00

The sound power levels are at fan source before any corrections have been made.

Noise Breakout From ECOVENT Plus Case

Refer to the table above, or for further calculation, the sound reduction for the ECOVENT Plus double skinned case is as follows:

Centre Frequency Hz:	63	125	250	500	1k	2k	4k	8k
Sound Reduction, dB	9	11	13	28	34	35	35	36

This should be deducted from the above sound power spectrum, and a further deduction made for measurement distance from case - 1 metre 8 dB, 2 metres 14 dB, 3 metres 18 dB, 6 metres 24 dB. This figure should be deducted from each octave band and will result in a sound pressure level spectrum at that distance. Heavy-weight panel infills available to further reduce noise breakout.

Electrical Details

Motor Size Kw	Max FLC per phase per fan	
	230 volt 1 phase	400 volt 3 phase
1.1	5.9	2.6
1.5	7.0	3.9
2.2	9.0	5.8
3.0	-	7.1
4.0	-	8.5

Silencers

The silencer codes also provide the dimensions;

e.g. VA4-60-60-120 is 600mm wide, 600mm high, 1200mm long.

These silencers **cannot** be fitted directly to the ECOVENT unit, a transition is required.

Silencers can be supplied to suit differing noise level requirements and duct layouts, consult sales office.



Size 1 - Plantroom/Ceiling Void

- Top or bottom access.
- Horizontal mounting.
- Handings may be left or right hand side (LHS shown).
- Isolator fitted on supply fan side of unit.
- Flanged connections 20mm Mez.

Plan View

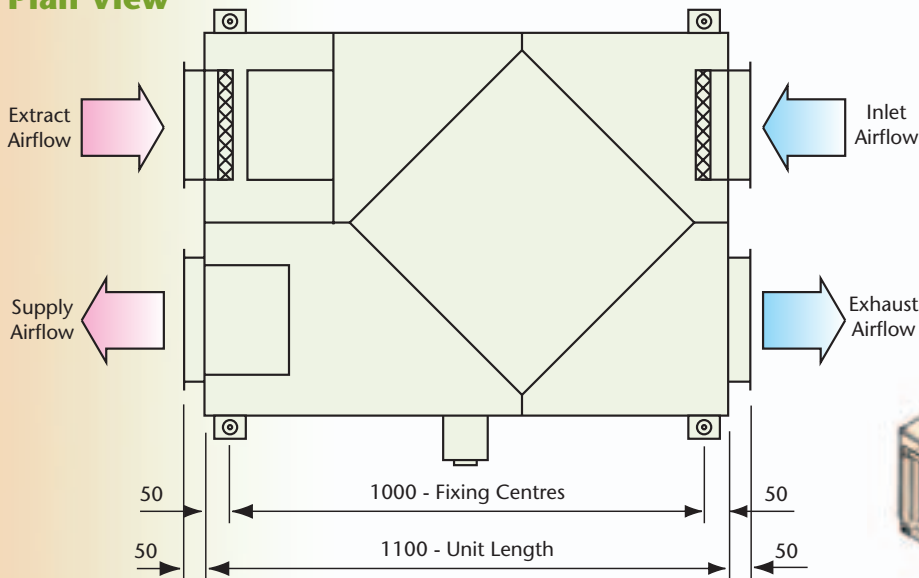

Isometric View

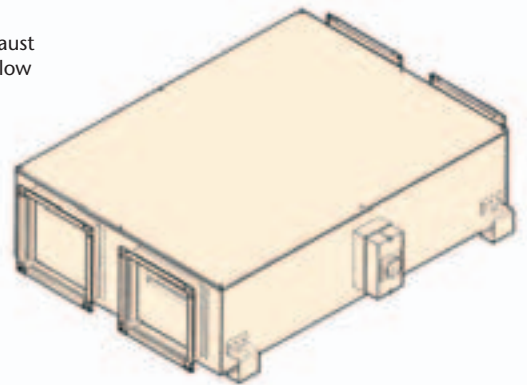

End View (Typ. Both Ends)

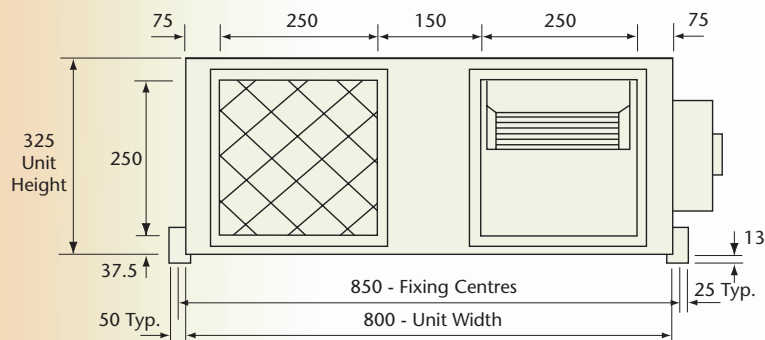

Mounting Feet



ø11mm hole suitable for suspension supports and floor fixing.
Foot incorporates ø30mm tooling clearance hole at top

Side View - With duct mounting electric or hot water heater

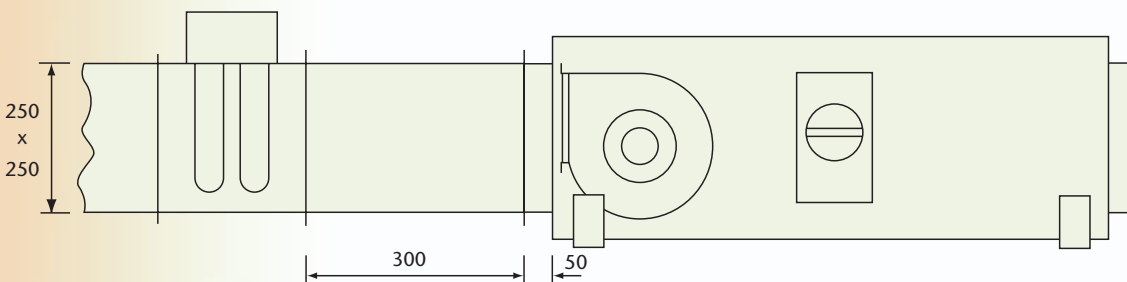

Unit Weight 60kg



Size 1 - Weatherproof

- Weatherproof construction.
- Top access.
- Handings may be left or right hand side (LHS shown).
- Optional isolator fitted on supply fan side of unit.
- Flanged connections 20mm Mez.

Plan View

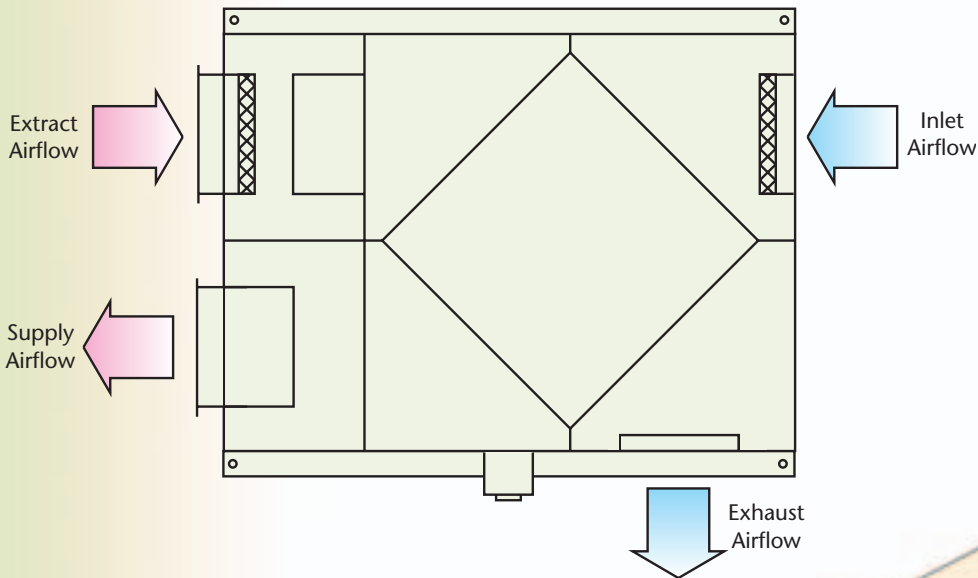

End View

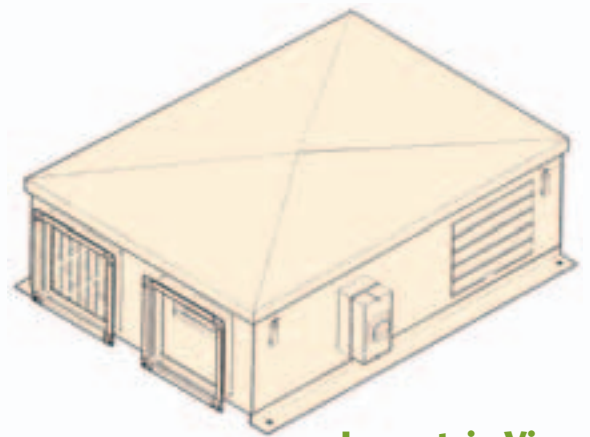
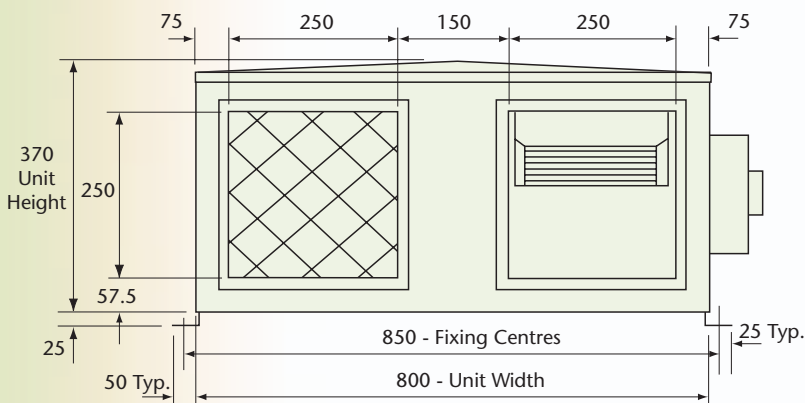

Isometric View

Side View

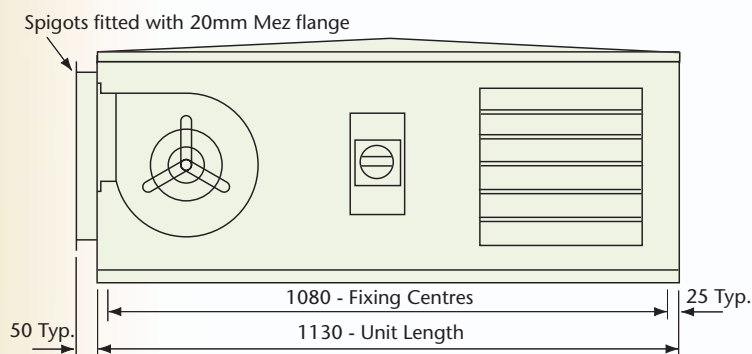

Unit Weight 75kg



Size 2 - Plantroom Units

- Side access to filters.
- Top or bottom access to fans and damper motor.
- Flanged connections 20mm Mez.
- Handings may be left or right hand side.
- Optional controls fitted on supply side.
- LPHW coil connections 3/4" BSP.

Flat Units

Plan View

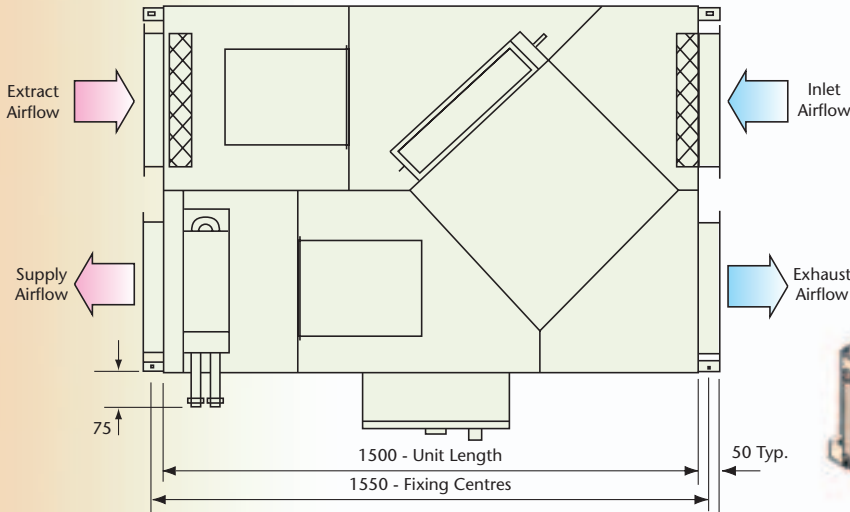

Unit Weight 110kg

Isometric View

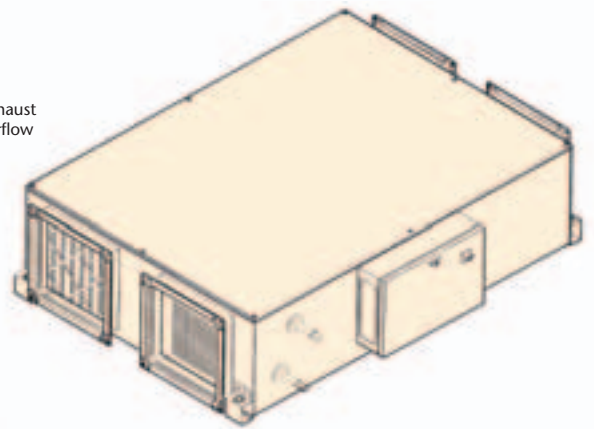

End View (Typ. Both Ends)

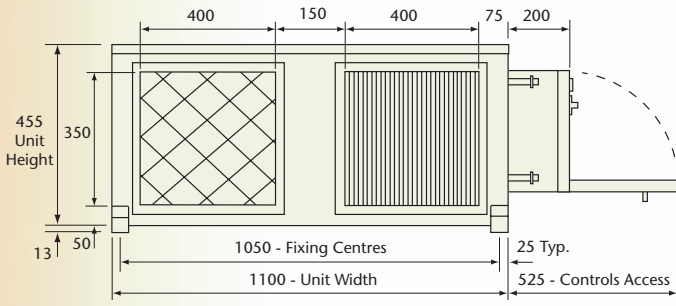

Mounting Feet

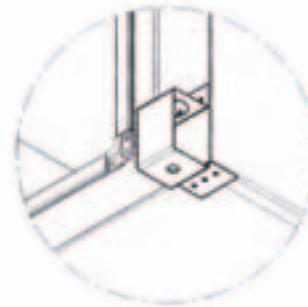

ø11 mm hole suitable for suspension supports and floor fixing. Foot incorporates ø30mm tooling clearance hole at top

Stacked Units

- Access and handings may be left or right hand side.

End View (Typ. Both Ends)

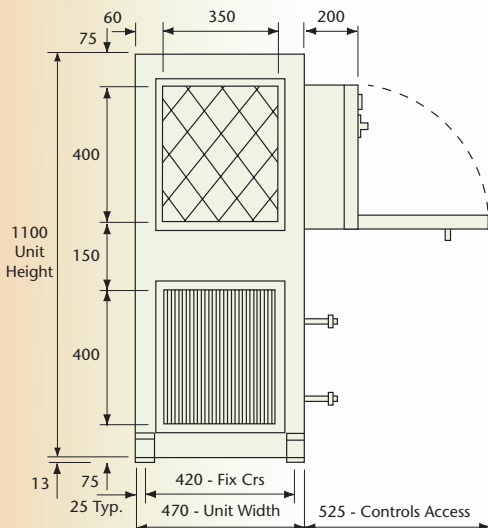

View on Access

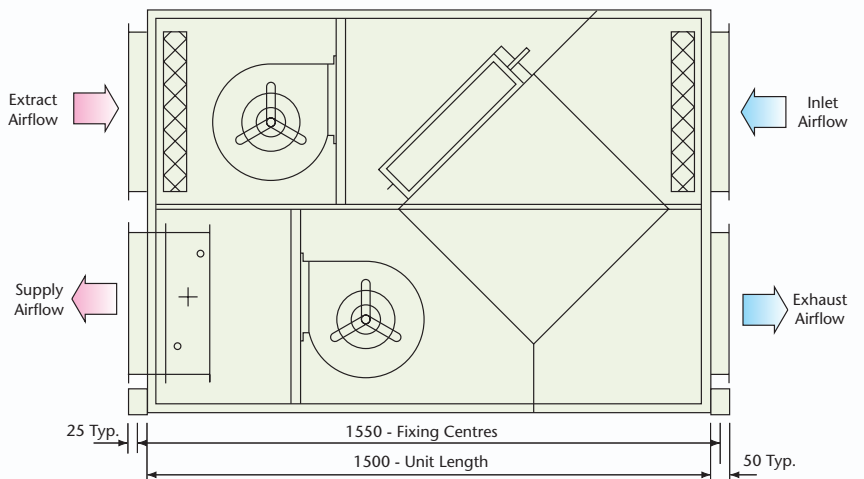



Size 2 - Weatherproof Units

- Top access via removable lid.
- Control panel (if required) will be adjacent to supply fan.
- Handings may be left or right hand side.
- Flanged connections 20mm Mez.
- LPHW coil connections 3/4" BSP.

Flat Units

Plan View

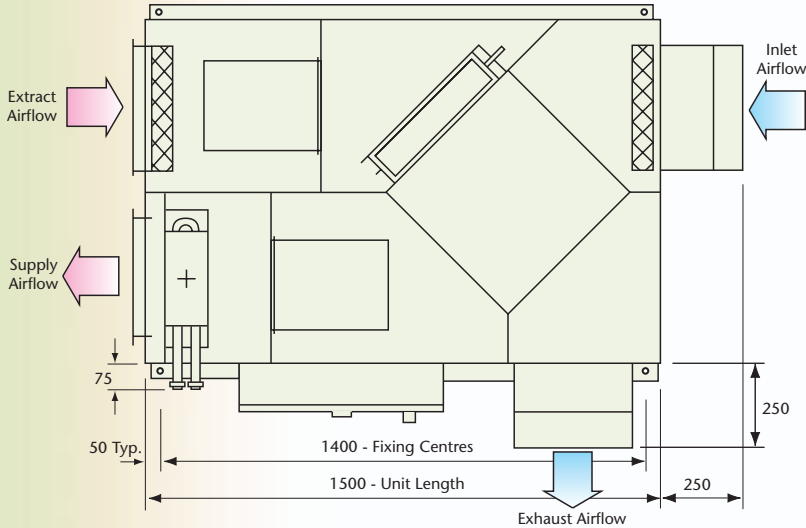

Unit Weight 130kg

Isometric View

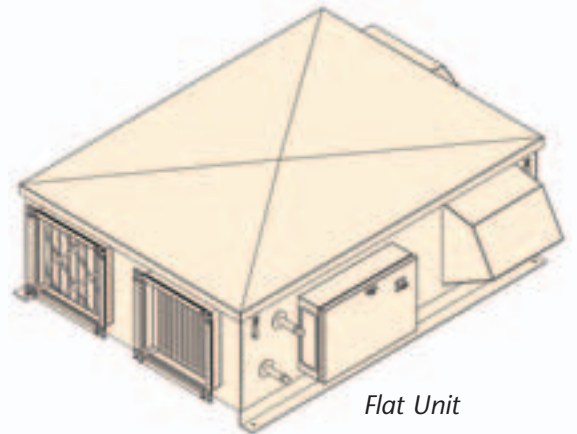

View on Spigots

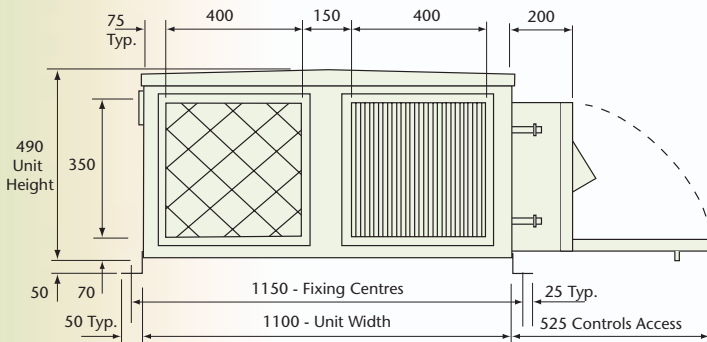

Isometric View

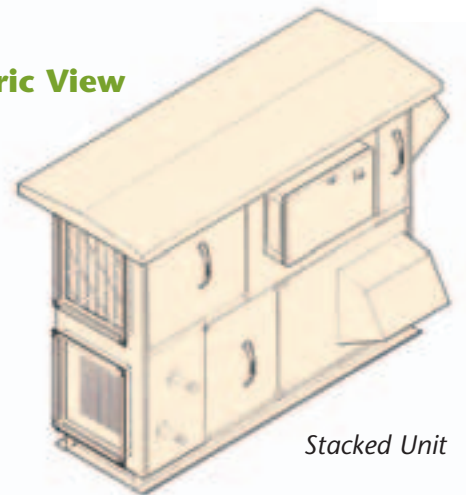

Stacked Units

- Access and handings may be left or right hand side.

View on Spigots

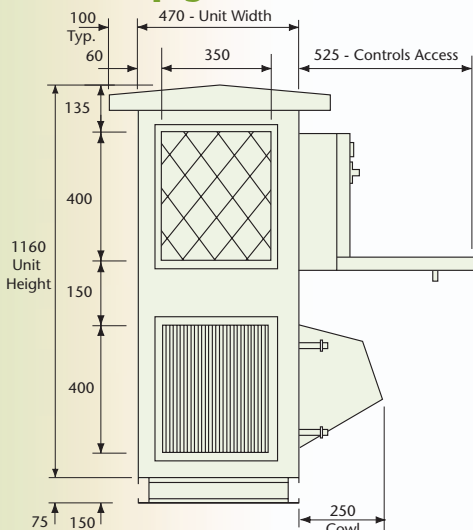

View on Access

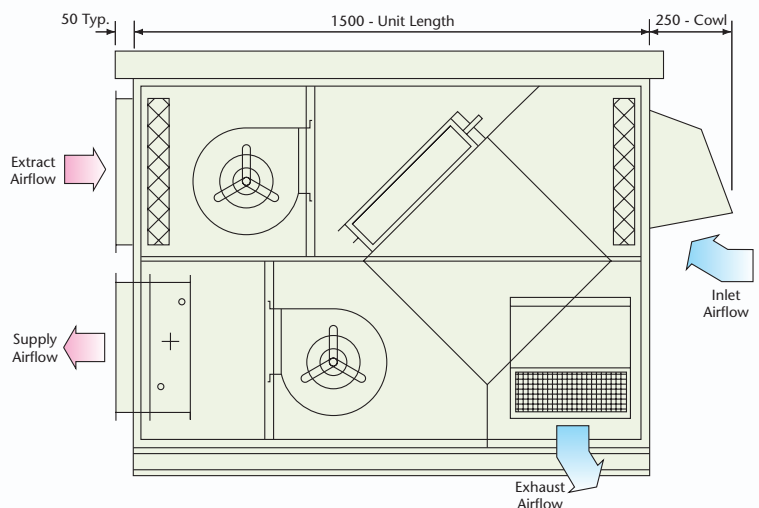



Size 3 & 4 - Plantroom Units

- Side access to filters, fans, damper motor.
- Flanged connections 20mm Mez.
- Handings may be left or right hand side.
- Optional controls fitted on supply side.
- LPHW coil connections: Size 3 - 1" BSP, Size 4 - 1 1/4" BSP

Flat Units

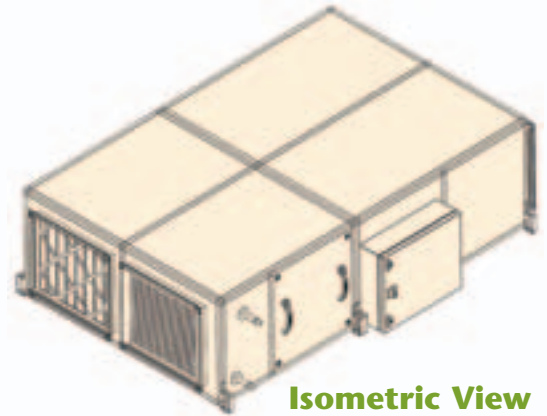
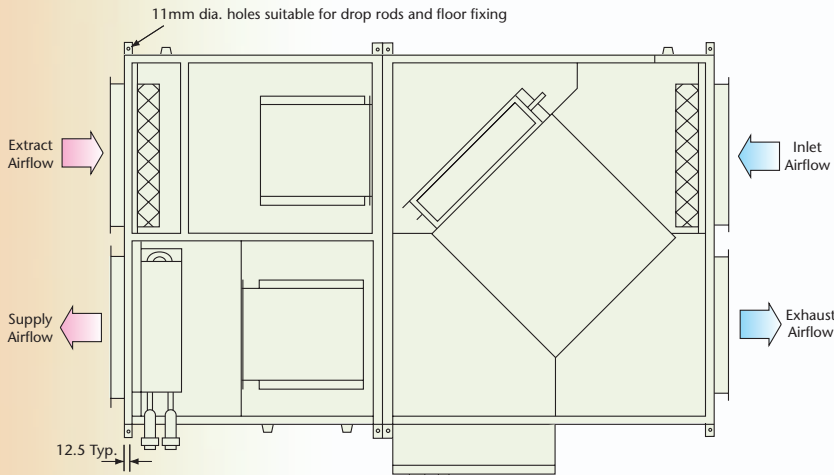

Isometric View

End View (Typ. Both Ends)

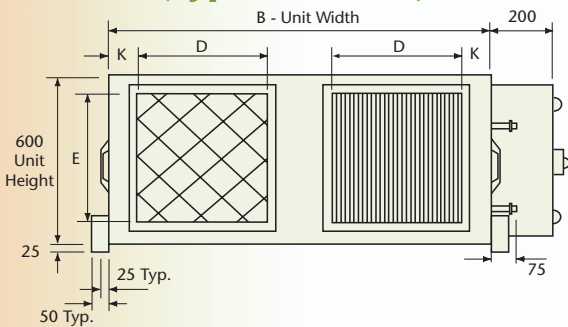

Supply Side View

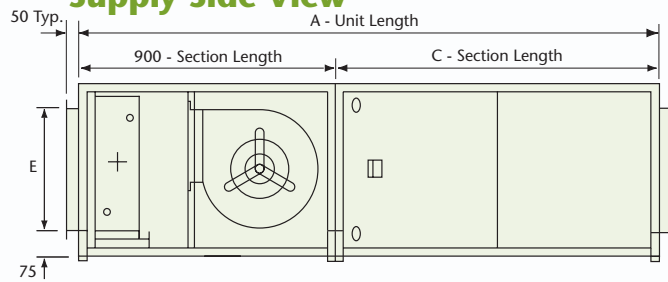

Stacked Units

- Access and handings may be left or right hand side.

End View (Typ. Both Ends)

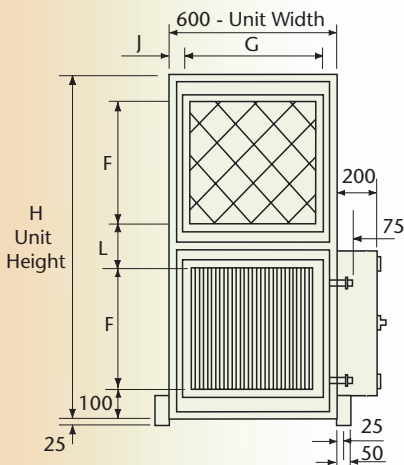

View on Access

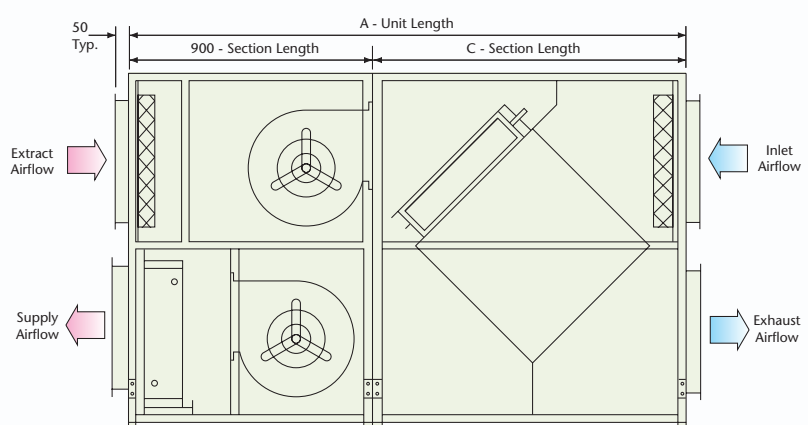

Unit Weights

ECOVENT PLUS SIZE	A	B	C	D	E	F	G	H	J	K	L	Total Unit Weight kg
3	2050	1300	1150	500	450	450	500	1275	50	100	175	320
4	2300	1425	1400	550	450	550	450	1425	75	87.5	125	370



Size 3 & 4 - Weatherproof Units

- Side access to filters, fans, damper motor.
- Flanged connections 20mm Mez.
- Optional controls fitted on supply side.
- LPHW coil connections: Size 3 - 1" BSP, Size 4 - 1 1/4" BSP
- Handings may be left or right hand side.

Flat Units

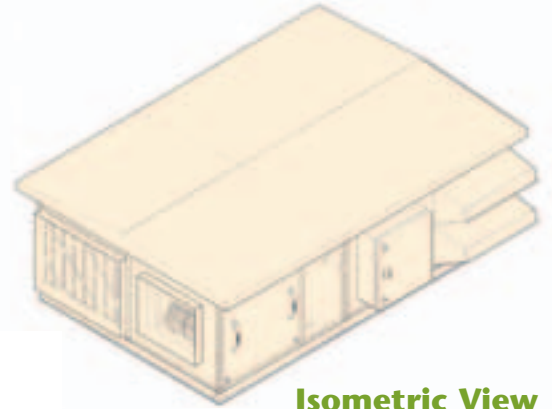
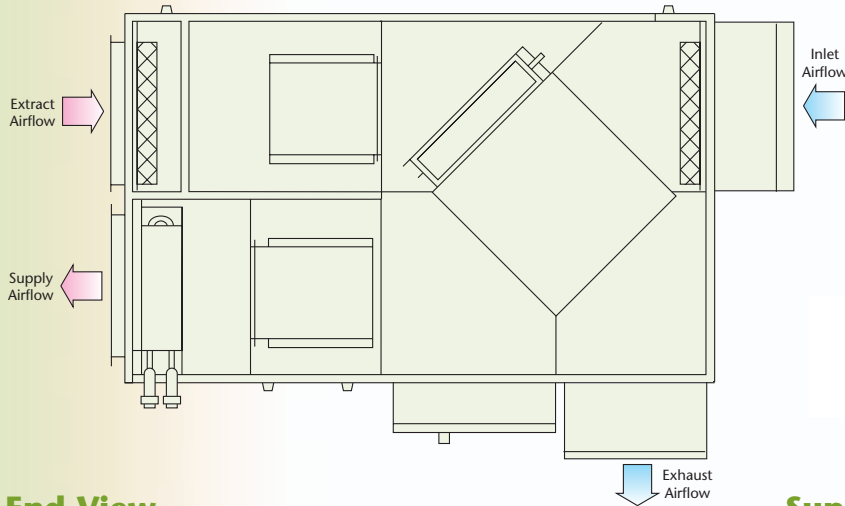

Isometric View

End View

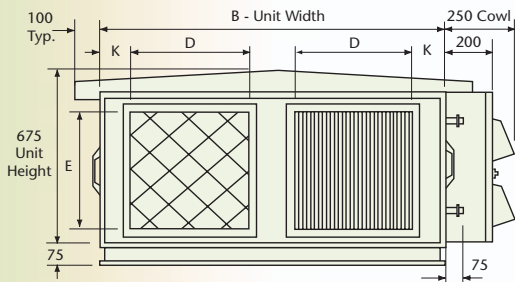

Supply Side View

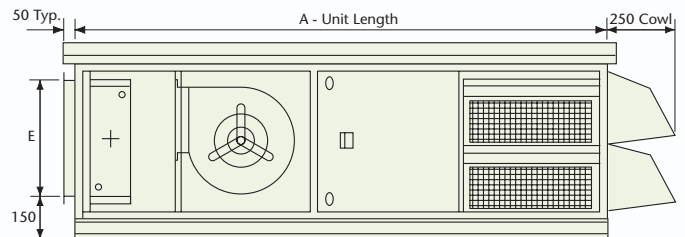

Stacked Units

- Access and handings may be left or right hand side.

End View

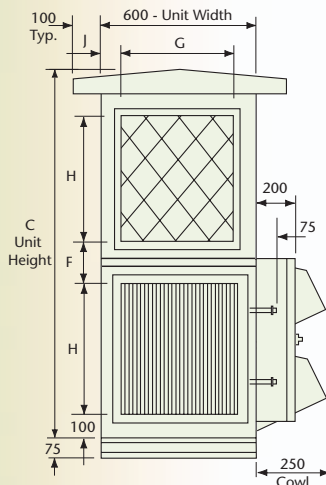

View on Access

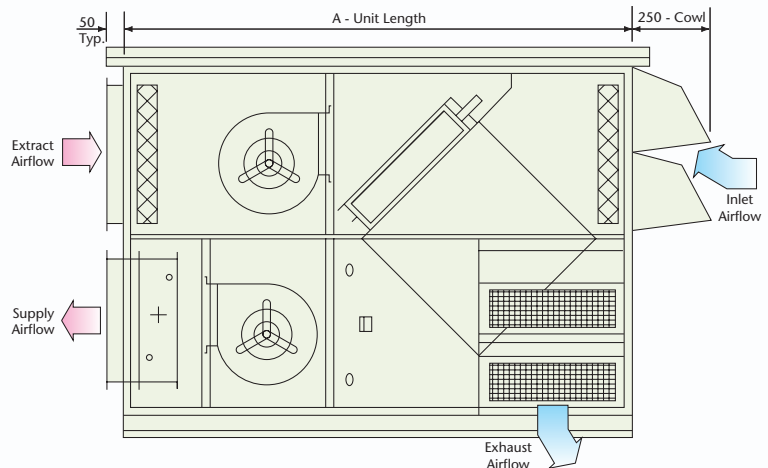

Unit Weights

ECOVENT PLUS SIZE	A	B	C	D	E	F	G	H	J	K	Unit Weight kg
3	2025	1300	1350	500	450	175	500	450	50	100	380
4	2275	1425	1500	550	450	125	450	550	75	87.5	450



Size 5, 6, 7 & 8 - Plantroom Units

- Side access to filters, fans, damper motor.
- Handings may be left or right hand side. • Optional controls fitted on supply side.
- Units supplied in two sections.
- LPHW coil connections: Size 5, 6 & 7 - 1 1/4" BSP, Size 8 - 1 1/2" BSP.

Flat Units

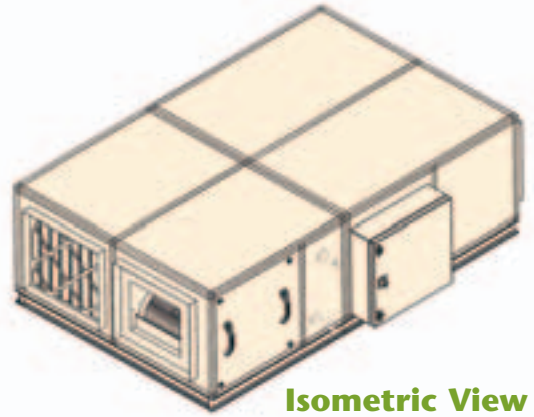
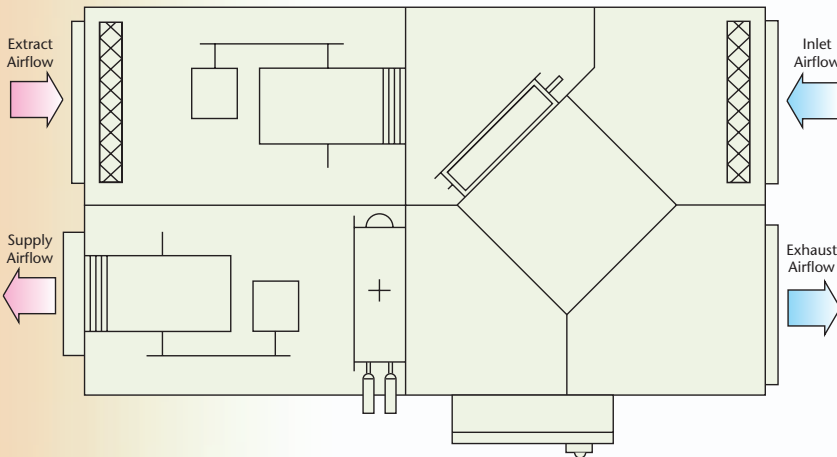

Isometric View

End View

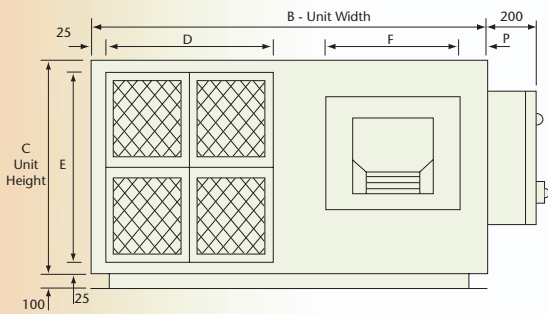

Supply Side View

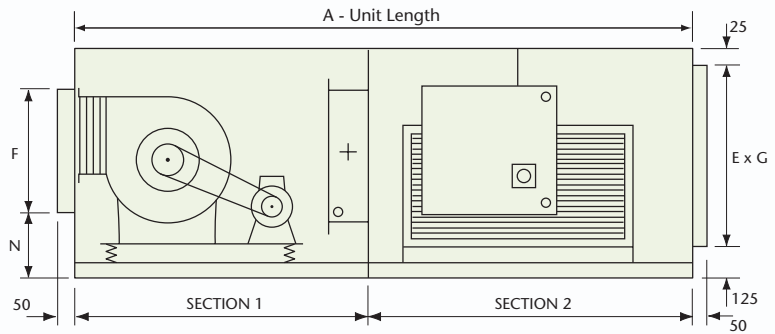

Stacked Units

- Access and handings may be left or right hand side. • Fitted control panel is optional.

End View

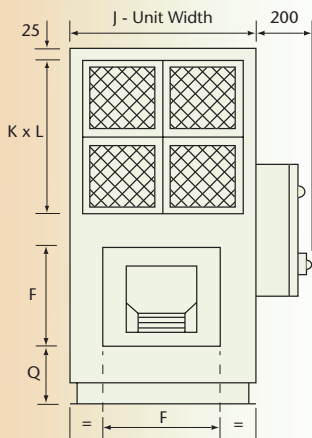

View on Access

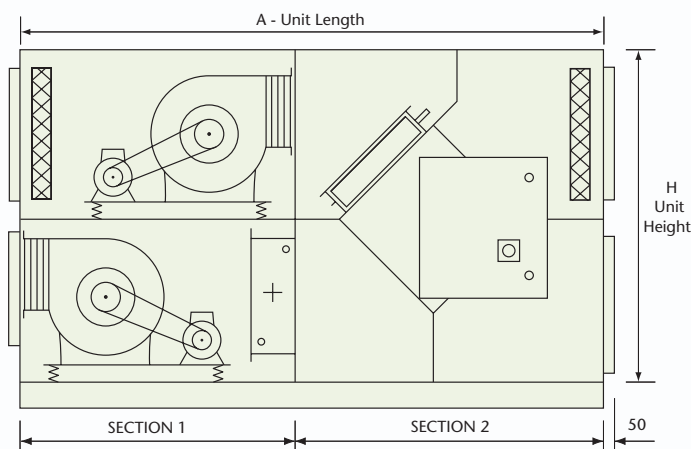

End View

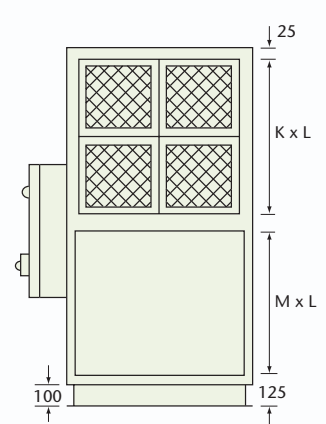

Unit Dimensions

ECOVENT PLUS MODEL	A-Length		Section 1		Section 2		B Width	C Height	D Width	E Height	F Square	G Width	H Height	J Width	K Height	L Width	M Height	N Height	P Width	Q Height	Weight kgs Section 1	Weight kgs Section 2
	LPHW	EHB	LPHW	EHB	LPHW or EHB																	
5	2525	2675	1300	1450	1225	1335	810	630	760	500	550	1335	810	630	760	550	250	90	200	205	110	
6	2700	2850	1325	1475	1375	1575	1000	750	950	600	675	1575	1000	750	950	675	250	100	200	305	170	
7	2700	2850	1325	1475	1375	1575	1000	750	950	600	675	1575	1000	750	950	675	250	100	200	325	190	
8	2700	2850	1325	1475	1375	1975	1300	950	1250	700	875	1975	1300	950	1250	875	300	150	300	415	250	



Size 5, 6, 7 & 8 - Weatherproof Units

- Side access to filters, fans, damper, motor.
- Handings may be left or right hand side.
- Units supplied in two sections.
- LPHW coil connections: Size 5, 6 & 7 - 1 1/4" BSP, Size 8 - 1 1/2" BSP.
- Optional controls fitted on supply side.

Flat Units

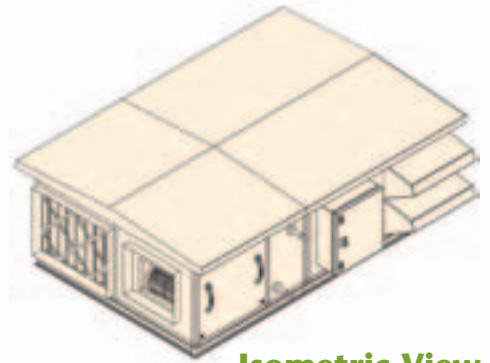
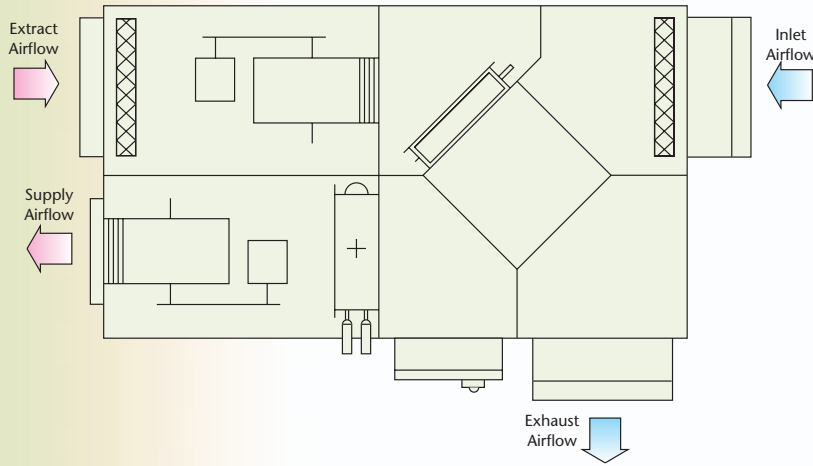

Isometric View

End View

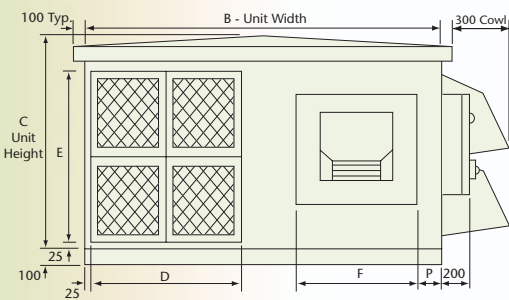

Supply Side View

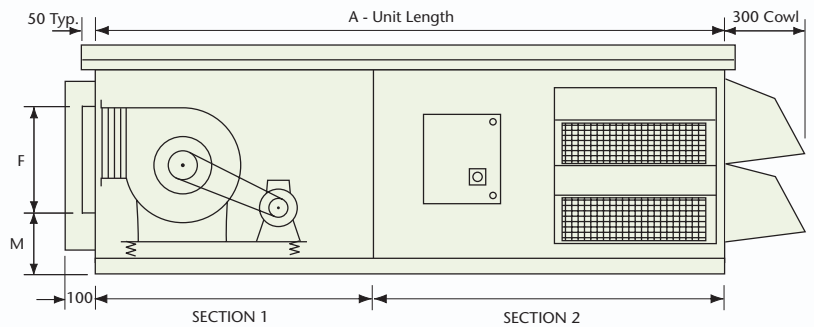

Stacked Units

- Access and handings may be left or right hand side.
- Fitted control panel is optional.

End View

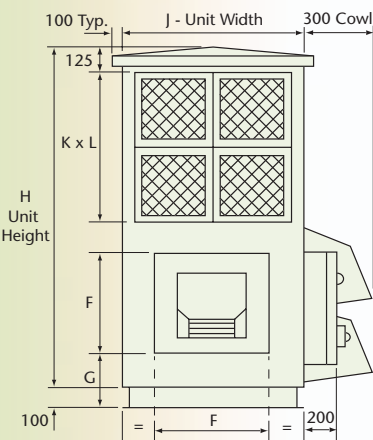

View on Access

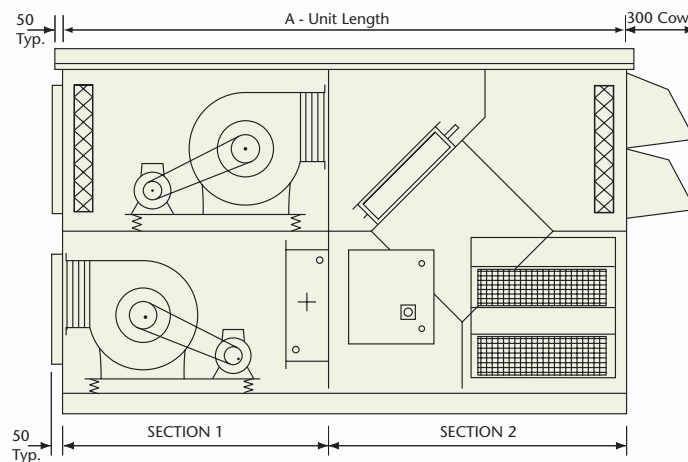

End View

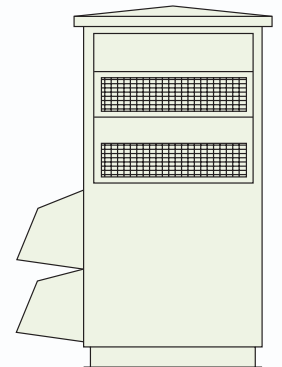

Unit Dimensions

ECOVENT PLUS MODEL	A-Length		Section 1		Section 2		B Width	C Height	D Width	E Height	F Square	G Width	H Height	J Width	K Height	L Width	M Height	Weight kgs	
	LPHW	EHB	LPHW	EHB	LPHW or EHB	Section 1												Section 2	
5	2525	2675	1300	1450	1225	1335	810	630	760	500	200	1435	810	630	760	250	205	110	
6	2700	2850	1325	1475	1375	1575	1000	750	950	600	200	1675	1000	750	950	250	305	170	
7	2700	2850	1325	1475	1375	1575	1000	750	950	600	200	1675	1000	750	950	250	325	190	
8	2700	2850	1325	1475	1375	1975	1300	950	1250	700	300	2075	1300	950	1250	300	415	250	

ECOVENT with Twin Extract Fans

As there is no cross-contamination of airflow it is possible to extract air from toilets, smoking rooms, changing rooms etc., and incorporate run and standby extract fans with an autochangeover system in the controls.

This facility is available with all units - flat or stacked, plantroom or weatherproof.

The case will be wider to accommodate the extra fan.

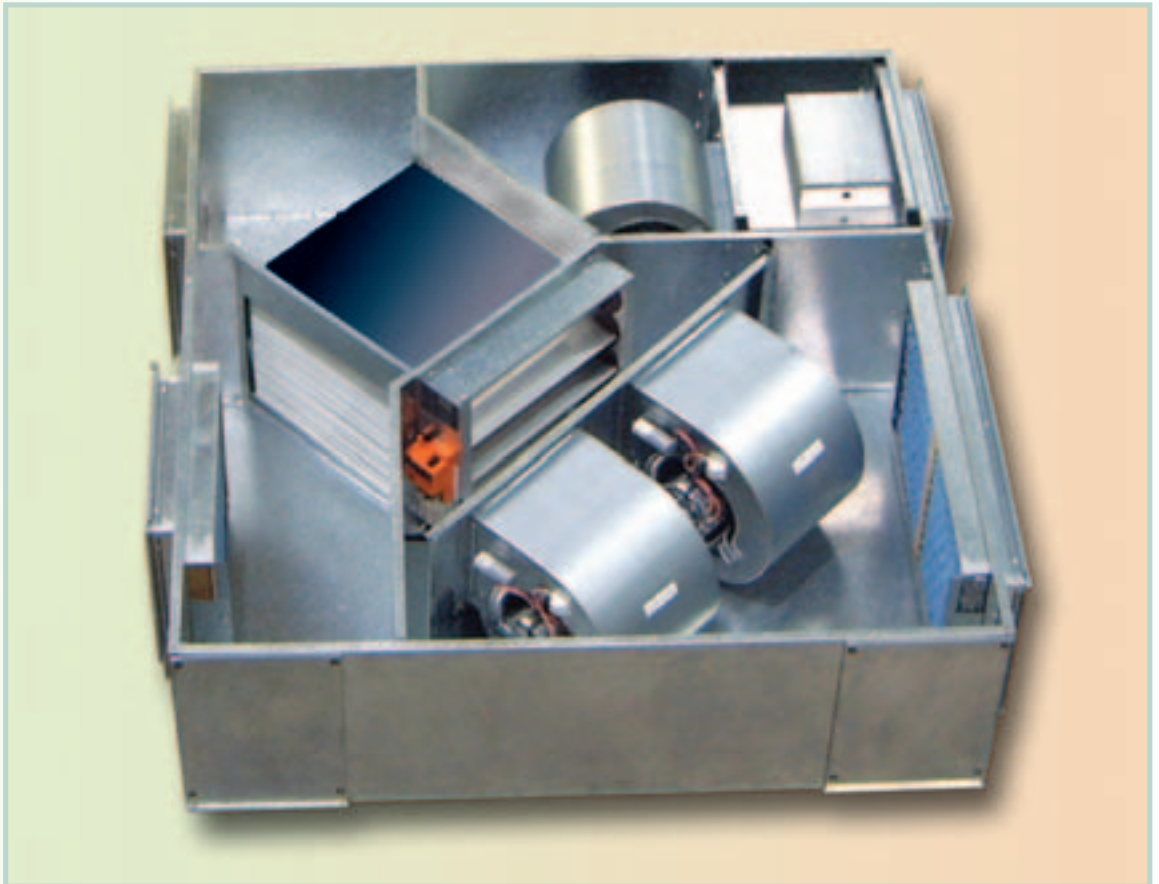

Additional width of unit with twin extract fans

ECOVENT PLUS	
UNIT	A*
Size 2	1600
Size 3	1950
Size 4	2100

* Approximate

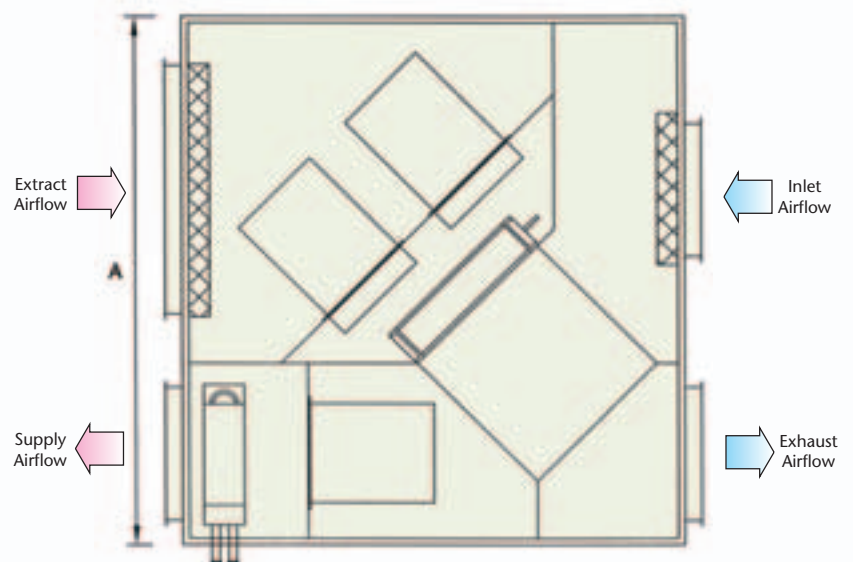

Plate Heat Exchangers

Cased for easy installation in ventilation systems

Standard features:

- Thermally lined case.
- 20mm Mez flange ductwork connections.

Optional features:

- Filters to inlet of both supply and extract airflow, with side access panels.
- Face and bypass damper, plus simple thermostatic control.
- Weatherproof housing.
- Drain pan to exhaust for high humidity applications.
- Larger sizes available - contact sales office.

Selection Curves

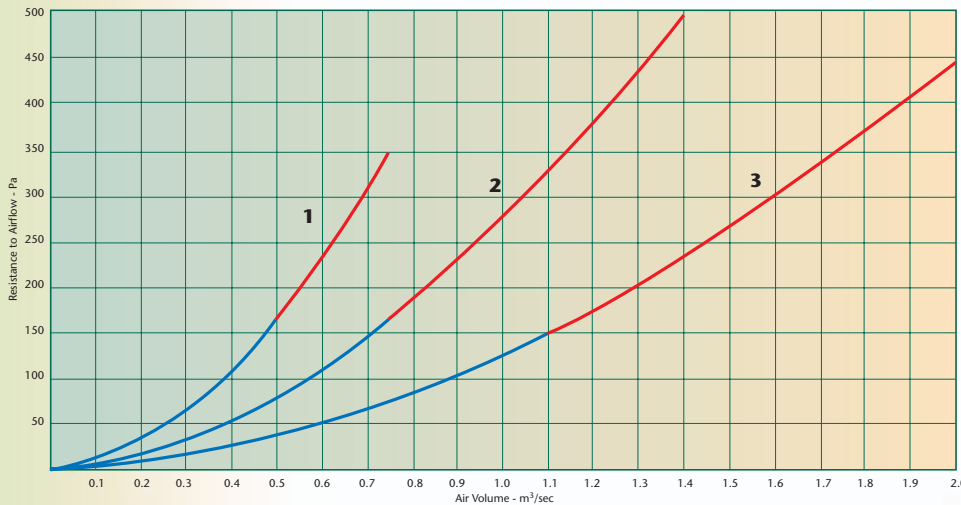

Fitted Filters

Pleated, synthetic disposable cell grade G4 (EU4).

Maximum pressure drop of filter in **BLUE** part of fan curve 75Pa when clean.

Do not use fitted filters if selecting from **RED** part of fan curve

Plan View

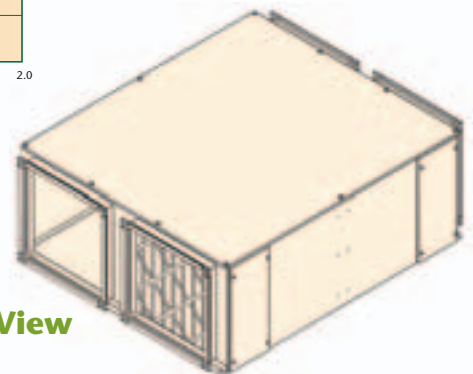
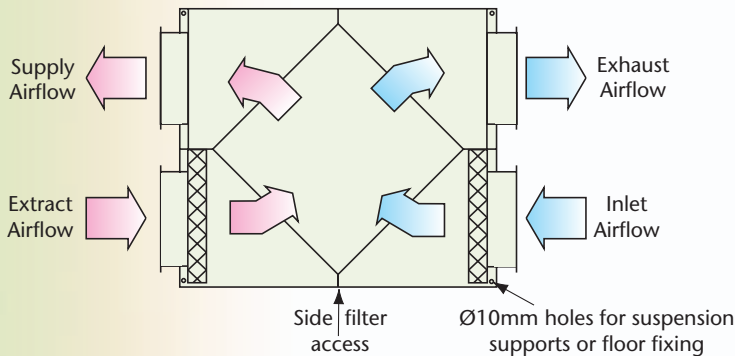

Isometric View

The ECObox can be used in conjunction with other VES products - SAM air handlers, REX extract fans, Airline, Breeze, Weathermaster, FLO₂ twin fan units and VES controls

End View (Typ. both ends)

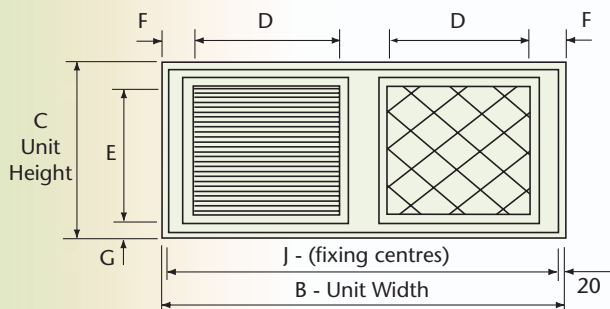

Side View

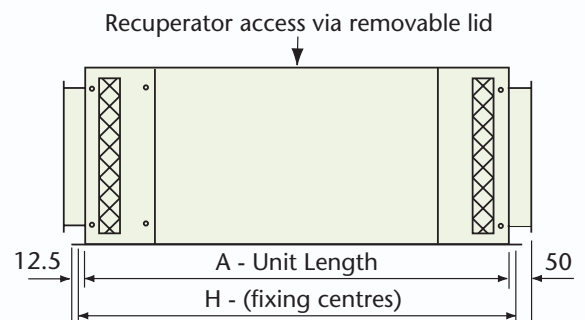

Unit Weights

ECOBX UNIT	A	B	C	D	E	F	G	H	J	Unit Weight kg
1	980	765	330	250	250	50	37.5	1005	725	45
2	1120	900	380	350	300	50	37.5	1145	860	60
3	1400	1185	420	450	350	75	32.5	1425	1145	75



Heat Recovery - Plate heat exchanger or Thermal wheel?

The plate heat exchangers used by VES in Ecovent Plus are completely maintenance free, and there is no cross contamination of air between supply and extract airstreams.

Thermal wheels have leakage between supply and extract, this cannot be avoided. They are also prone to bearing failure, wheel motor and drive belt failure. They will clog up over a period of time and are not easy to clean. Replacement of the wheel is necessary if the bearings fail, this is a major cost item.

There are two types of thermal wheel, standard and total energy. The latter contains a dessicant coated wheel which absorbs moisture on extract and releases it on supply side. These have high efficiency due to latent recovery, but also a higher air pressure drop, leading to larger fan motors, so the overall unit size will be greater than a comparable plate heat exchange unit.

The standard thermal wheel normally installed has coiled aluminium strip media which has comparable heat transfer properties to the plate heat exchanger.

The designer should be aware that high efficiency levels only occur in latent transfer applications. This does not apply in normal sensible heat applications, when in both types of unit the heat recovery is likely to be in the region of 50%.

Now compare prices - Ecovent Plus units are going to cost considerably less than a heat wheel unit of the same duty, providing faster payback on capital cost.



Energy conservation

All Ecovent Plus units have been tested to BS 848 Part 1, and the Specific Fan Power recorded at each duty point. They all meet the 2.0 watts/litre/second requirement as detailed in the Document L2 of the Building Regulations 2000, with the general exception when the selection point is of small volume and high pressure at the top end of the fan curve. The Technical Department can advise the SFP at any duty point. In addition, the fitted controls package has been designed to maximise energy saving and heat recovery under all conditions.

Specifying the unit you require:

Everything has a code-

- Plantroom, flat **P**
- Weatherproof, flat **W**
- Plantroom, stacked **SP**
- Weatherproof, stacked **SW**
- Hot water heater **W**
- Electric heater **E**
- Twin extract fans **TE**
- Special colourstate **BS** or **RAL** colour
- Double skinned **DS** Sizes 3 - 8 only
- Rank special design **S**

Handlings-

- Supply fan (and access) left or right hand side **L** or **R**
- Size 1 & 2 only:
Flat unit supply fan left or right hand side, top access **LT** or **RT**
Flat unit supply fan left or right hand side, bottom access . . . **LB** or **RB**

i.e. **ECO 326 / SW - W / L**

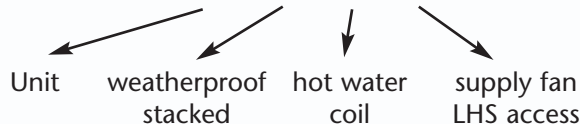

For sizes 5, 6, 7 & 8 please include supply & extract air volumes, and external resistance for drive selection.

VES Andover Limited
Eagle Close, Chandlers Ford Industrial Estate,
Chandlers Ford, Eastleigh, Hampshire SO53 4NF
Tel: **08702 40 43 40**
Fax: **08702 40 45 50**
e-mail: vesltd@ves.co.uk
www.ves.co.uk

VES reserve the right to amend product specifications and details without notice.



ISO 9001-2000
Cert. No. Q5375

© 2004 VES Andover Ltd.
Issue 1 - 07/2004