

Multi-Service Chilled Beams

The Worldwide CIBSE / ASHRAE Conference 2003, Paper 60.
As written and presented by Neil Pennell, Land Securities PLC
and Guy Hutchins, Trox UK Ltd.

25th September 2003
Edinburgh International Conference Centre, Scotland.



TROX[®] TECHNIK

Reproduced with the kind permission of the Chartered
Institute of Building Services Engineers CIBSE.

Multi-Service Chilled Beams

1.0 Summary

This paper aims to demonstrate the advantages of Multi-Service Chilled Beams when used on large fast track refurbishment projects.

Empress State is a 415,000 sq ft office development for Land Securities which has been comprehensively refurbished to provide state of the art business accommodation for future Landflex customers.

An integrated MSCB providing cooling, ventilation, lighting, fire alarms and sprinkler distribution was specifically developed for the general office areas of the building. The final product was the result of a collaborative effort involving the client, design team and key contractors and suppliers working closely with the beam manufacturer.



Existing Structure - circa 1960's



Refurbishment - 2003

2.0 Introduction

On the 9th of October, 2001, the Hammersmith and Fulham Planning Committee approved Wilkinson Eyre's stunning design proposals to breathe new life into Land Securities Empress State. The building always dominated the West London skyline since its original construction in 1959 as a hotel. At the time it was the tallest building in West London and the fourteenth tallest building in London.

Before the building was completed it was let to the government to be occupied by the Ministry of Defence and there was a change of use to offices. Whilst it was occupied by the MoD it had a colourful history with NATO and the secret service in part of the building, no doubt if walls had ears the building would have many secrets to tell!

In May 2001 the design team were given the brief to refurbish and extend the existing building. A planning application was made in June 2001 resulting in a resolution to grant planning in October 2001.

The concept was to produce a flexible building that from an occupiers view point was stimulating and fun to work in with supporting workstyle amenities on site. New low rise buildings around a public piazza space at the base of the tower provide leisure, childcare, and restaurant facilities. A café breakout area on the Ground floor, 1st floor IT suite, meeting rooms on the 14th floor and a rotating bar on the 30th floor are all provided to serve the building occupiers.

The building provides over 400,000 sq ft of modern office space which will be let on Landflex terms. Landflex from Land Securities is an integrated accommodation package that allows a company to match their accommodation requirements to their business plan and reduce their total accommodation costs.

The unusual tricone floor plate with escape stairs at each apex and a central staircase facilitate up to three individual tenancies per floor.

The original retained floors (with the exception of ground and first) have tight slab to slab dimensions resulting in floor to soffit heights of around 2.8m. The building has a restricted basement area, and the revolving bar at roof level with its panoramic views over London made it off limits to the services designers to use for plant space.

The lack of plantroom space was solved by the construction of a two storey plantroom on the east elevation and by creating an underground boilerhouse under the car park. The underground plant area also provides space for the sprinkler tank and is linked to the main building by a service tunnel. To the west of the site is a residential area and locating the main plant on the east side of the building ensured that not only was the distance from noise sensitive areas maximised but also the noisy plant was effectively screened by the building itself.

The existing cladding was at the end of its economic life, and its replacement gave the architects an opportunity to maximise the daylight penetration by using full height glazing on the south façade where the floor plate was being extended by 5.5m. They also added a brise soleil to reduce the solar load over this face. This, together with new cladding to the east and west façades, significantly improved the overall performance of the building envelope. The original floors at the top of the building were demolished and three new fully glazed floors and a revolving bar added.

Multi-Service Chilled Beams

Land Securities have a long standing commitment to sustainable development and with their ongoing management of many properties have significant experience of active energy management and life cycle maintenance issues. Consistent with their stated environmental policy all major office developments are subject to a BREEAM assessment, Empress State (under the 2002 version) achieved a "very good" rating.

2.1 Services Strategy

Finding a comfort cooling solution that could satisfy all the different use requirements in the building ranging from general offices to a conference centre and bar was an interesting challenge for the mechanical services designers. The mixture of old and new construction, varying slab to ceiling heights and differing cladding treatments required a flexible and innovative approach.

M. G. Partnership's response to this was to design a main plant and distribution infrastructure which could support a range of different solutions. Chilled water is distributed through three sets of vertical risers to the floors where plate heat exchangers provide hydraulic separation between the primary and secondary circulation systems. Low level perimeter heating is provided by a combination of radiators and underfloor perimeter convector heaters (depending on floor height) enabling alternative terminal unit solutions to be chosen to deliver ventilation and cooling to the space.

Fresh air ventilation is provided from three on-floor air handling plants supplying conditioned air to each potential tenancy zone.

A separate 24 hour resilient chilled water system serves the central IT suite with risers through the central core to serve future tenant on floor critical loads and the orbit bar at the top of the building.

With minor adjustments to the secondary chilled water systems and on floor air plants the main plant can support any combination of chilled ceilings, chilled beams or two-pipe fan coil units on a floor by floor, or even zone by zone, basis.

The architectural concept for the newly constructed 27th, 28th and 29th floors was to create a high level of transparency at the top of the building using full height glazing on each elevation. These penthouse style floors have the potential to be highly cellularised and may also be used as special event space for fashion shows and product launches etc. A two-pipe fan coil unit solution was chosen for these floors to cater for the high loads and to provide for maximum flexibility of use.

Fan coils were also selected for the 14th floor meeting rooms and conference suite where despite the low headroom a more traditional metal pan acoustic ceiling was used.

By far the largest area of the building is served by a Multi-Service Chilled Beam and the reasons which led to its selection for the low headroom floors are discussed in detail in the following sections of this paper.

3.0 Why were Multi-Service Chilled Beams selected for the Low Height Structure?

The existing structure of the retained floors at the Empress State, circa 2.8m slab to soffit, meant traditional air conditioning systems when coupled with a suspended ceiling would result in very low floor to ceiling heights. The building profile presented elevations to the east, west and south with the southern

elevation incorporating full height glazing albeit partially protected by external brise soleil, resulting in a peak load of 100 W/m² over the perimeter zone. Meeting the load demands of the extended and reclad building needed a comfort cooling solution which would achieve the comfort levels required for a modern office user while maximising the available height.

Consideration was given to three systems at concept stage:

- Fan Coil Unit
- Chilled Ceiling
- Exposed Multi-Service Chilled Beams

Each of these systems has a number of attributes:

3.1 Fan Coil Units

- High Flexibility
- High capacity cooling (150+ W/m²)
- Deep ceiling void required (300mm min)

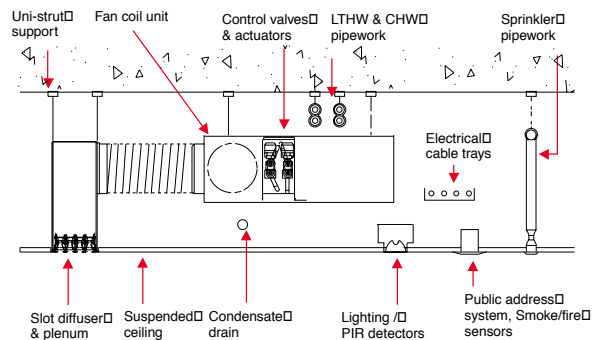

3.2 Chilled Ceiling

- Limited flexibility
- Cooling capacity of 70-80 W/m² per active m² of ceiling, 50-60 W/m² net across floor area, (excludes area of lights, ceiling grid, plaster margin etc.), plus ~25 W/m² from primary air supply; total cooling 75-85 W/m².
- Shallow ceiling void (150mm).
- High comfort levels (radiant cooling) and low air movement.

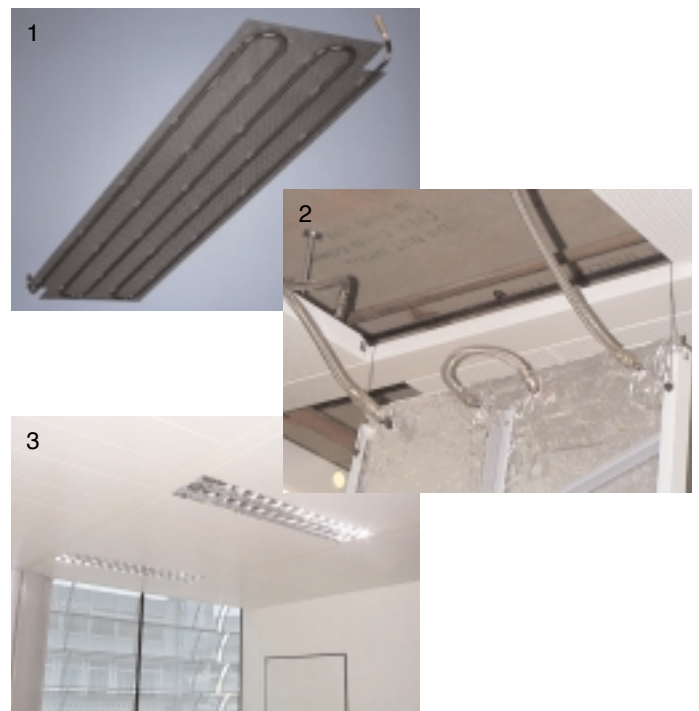

Multi-Service Chilled Beams

3.3 MSCB

- Flexible.
- High cooling capacity (150 W/m²); Empress State beam provides 1700W over a 4.2m active length.
- No ceiling void - exposed slab.
- Prefabrication and integration of other services, with accelerated construction program.



3.4 System Selection

Having considered the relative merits of each system the high loads reduced the choice to either fan coil units or Multi Service Chilled Beams. The diagrams below show the benefit of using Multi Service Chilled Beams to maximise the impression of height within the space, this, coupled with the advantages of pre-fabrication, integration of other services and 'cost in use', made MSCB the obvious choice.

Exposed multi-service chilled beams - typical floor

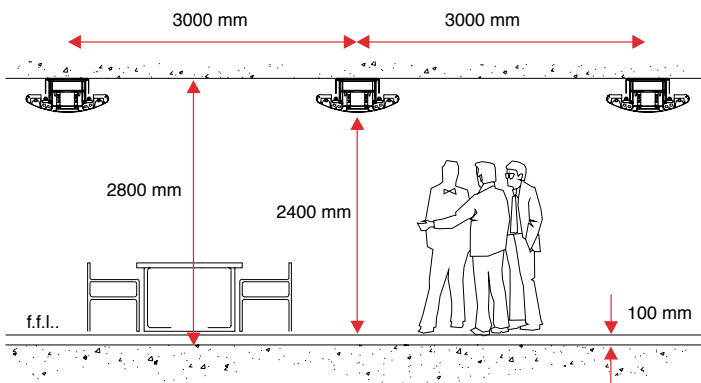

The soffit or 'ceiling' height with the exposed MSCB is 2700mm above finished floor level.

Fan coil units and suspended ceiling - 14th floor

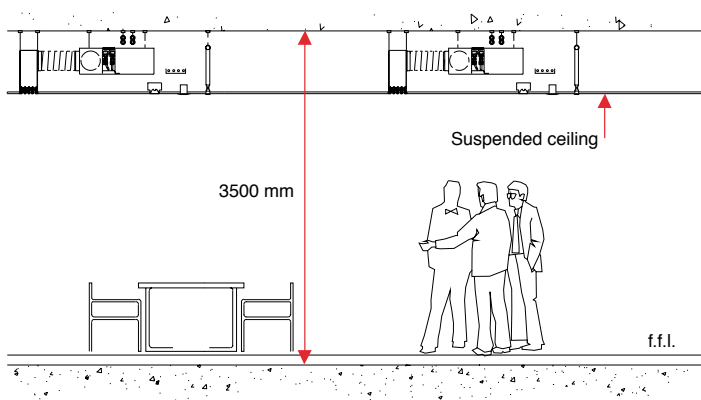

The suspended ceiling height with the FCU is 2400mm above finished floor level.

4.0 Aesthetic Design

Wilkinson Eyre Architects fully supported the choice of MSCB's which in their words "minimised the impact of contemporary service requirements within an existing building that had a minimal floor to ceiling height. The use of exposed beams meant that a full suspended ceiling could be avoided. Bays of office space were created, maximising the existing floor to ceiling height resulting in an optimised volume for the end user. The beam layout was also used to accentuate the existing sweep of the building's tricorn or 'Y'-shaped concave plan".

"The casing was designed to create a fine visual sight line from the office floor to reduce the bulk of the beam. Perforated panels were employed to further reduce the degree of mass to the top of the beam whilst the aerofoil extrusions taper the base to a fine edge that is softened by light from the office space. The beam provides the majority of electrical services to the office floor including lighting, lighting control and fire alarms, and in doing so further reduces the impact of components that would have had to be suspended across the ceiling."



Prototype curved MSCB



Installed flat face MSCB



South Elevation and Brise Soleil

Exposed MSCB + Soffit / Window Head Interface (section courtesy of Wilkinson Eyre)

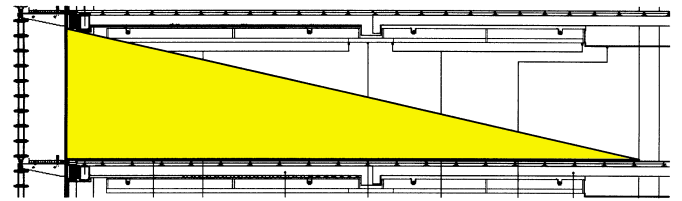

Suspended Ceiling / Window Head Interface (section courtesy of Wilkinson Eyre)

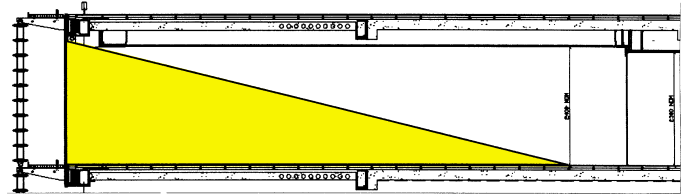

4.3 Beam Evolution

During the course of design development, the aesthetics of the beam changed from a curved unit to a flat-faced design with curved outer edges. The original concept, with a curved face, (see below) was designed to run parallel to the façade and needed depth to accommodate pipework and ductwork distribution to support serve beams up to 28 metres in length.

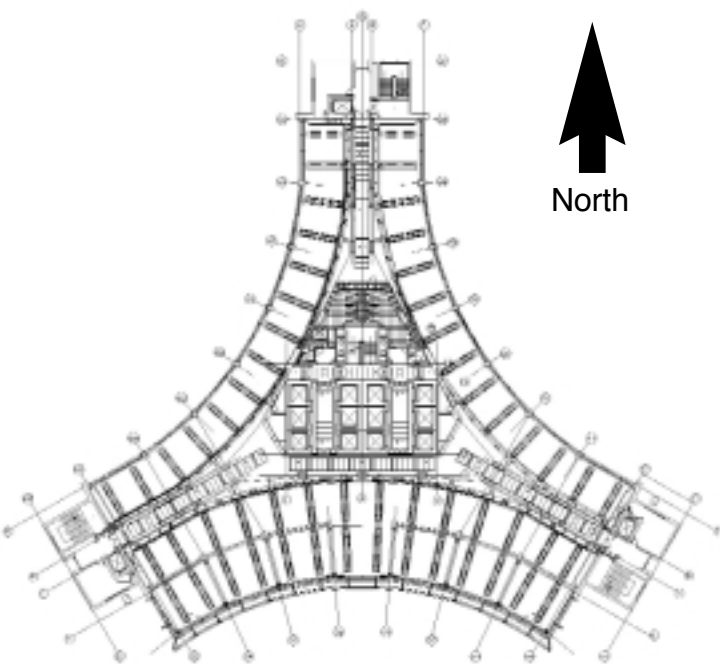

Typical MSCB Floor Plate - Courtesy of MG Partnership



Sketch of curved MSCB

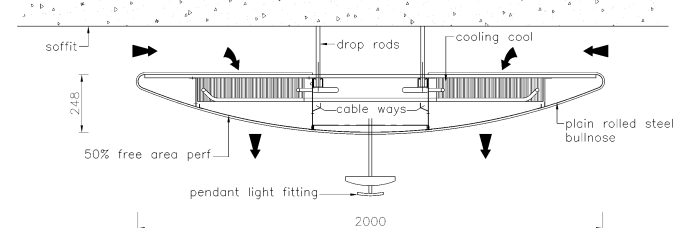

Detail of curved MSCB

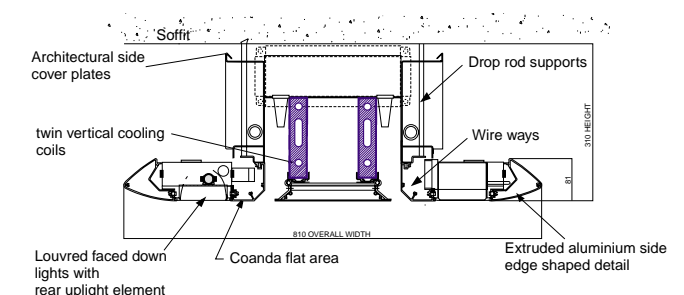

Detail of flat faced MSCB

4.1 Full Height Glazing

The extended south façade incorporated full height glazing to maximise the natural light on this deep plan elevation. With the increased natural daylight comes an increased solar load, which although mitigated by an external brise soleil the beam needed to deal with a high solar gain in the perimeter zone which combined with small power and occupancy loads totalled 100 W/m².

4.2 Natural Daylight

By exposing the soffit and using a central corridor zone to distribute services to the MSCB's, the need for a dropped ceiling bulkhead at the perimeter required for other solutions was eliminated. This enabled the maximum level of daylight penetration into the office floor-plate, see details below.

The adoption of a central services distribution bulkhead allowed the beams to be run perpendicular to the façade reducing the services distribution requirements and enabling a much more compact design solution.

Multi-Service Chilled Beams

4.4 Finishes

Natural anodised aluminium has been widely used throughout the building for a number of reasons. The material is both durable, lightweight and also provides a modern finish. There are a number of elements within the building that are finished in this way:

- Window frames
- Façade panels
- Brise soleil
- Exposed Multi-Service Chilled Beams

The selection of natural anodised aluminium MSCB's provides continuity through the design.

4.4.1 Aluminium Extrusion

The use of aluminium extrusions enables precise aesthetic profiles to be continuously reproduced to tight tolerance levels. This process aids the butt jointing of shaped beam lengths where required. Keyways are drawn into the extrusion die, which facilitate a rapid assembly process of the beam components.

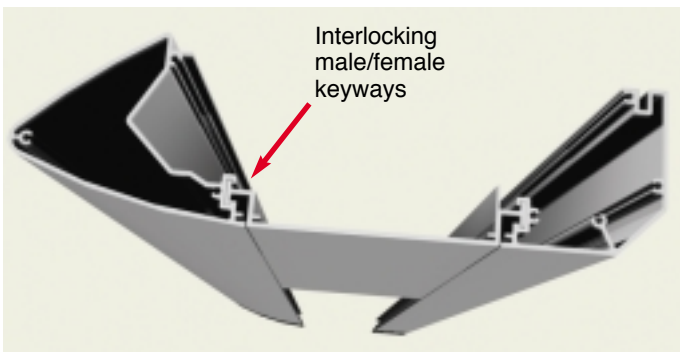

Aluminium Extrusion Keyways

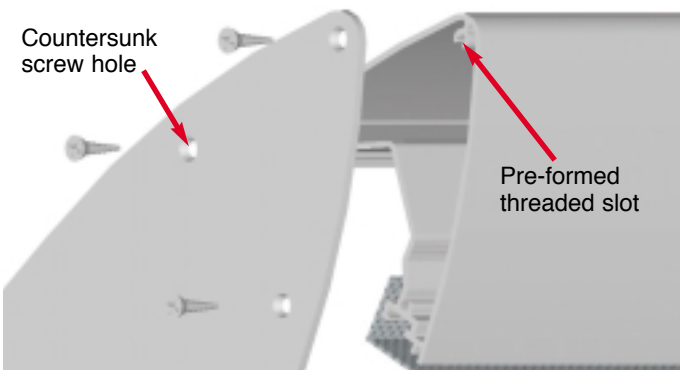

End Wall fixing plate



MSCB, Brise Solies, Window Frame

5.0 Acoustics

The elimination of the suspended ceiling increases the reverberation time in the space. Perforated metal ceilings do have the advantage of providing an absorbing surface, helping to control sound reflections in the office space. Tests were carried out to assess the reverberation time of the space with the exposed soffit and MSCB solution, and an acceptable working environment is achieved when carpets and furniture are introduced. If further control measures are found to be necessary, soft absorbing panels can be fixed to the soffit to fine tune the acoustic environment.

6.0 Low Maintenance

The client focus on 'through life' costs encouraged the team to eradicate high maintenance items wherever possible. The chilled beam technology at the heart of the exposed MSCB will ensure that minimal attention of the coil will be necessary. The design avoids the use of terminal filtration, associated with fan coil solutions, reducing the operating costs of the system. Cooling coils will require periodic vacuuming and the hinged face, which can be seen on the photograph below, provides easy access to the coils.

The beam has been designed to allow simple access from below to carry out maintenance on items such as:

- Lamp replacement
- Control valves and actuators
- Lighting control modules

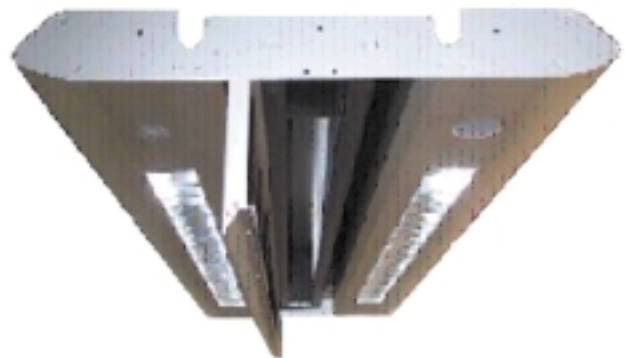

6.1 Whole Life Costs

The beam is designed to require little or no maintenance and whole life costs show, over a 25-year period, chilled beams compare favourably with traditional fan coil unit solutions.

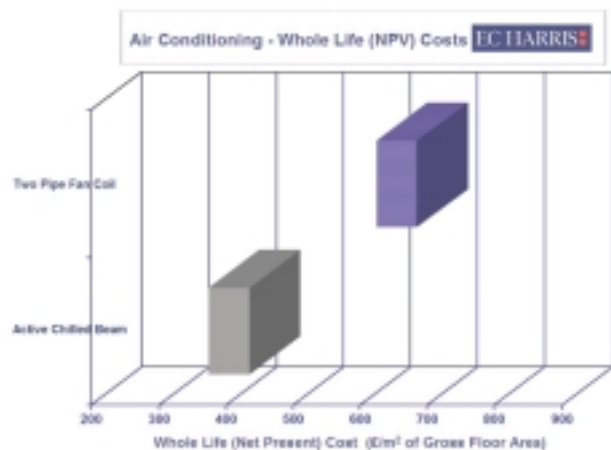

Multi-Service Chilled Beams

7.0 Integrated services

The design of the Empress chilled beam incorporated the following services:

- Cooling
- Fresh air ventilation and maximum humidity control
- Lighting & lighting control modules
- Emergency lighting
- PIR detectors
- PA/VA speakers
- Service route for sprinkler distribution

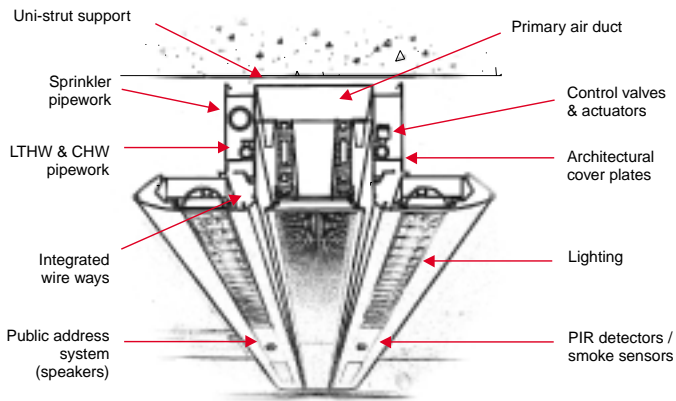

7.1 Cooling

The details below show a cross section through the beam, cooling coil and the pipe tail locations.

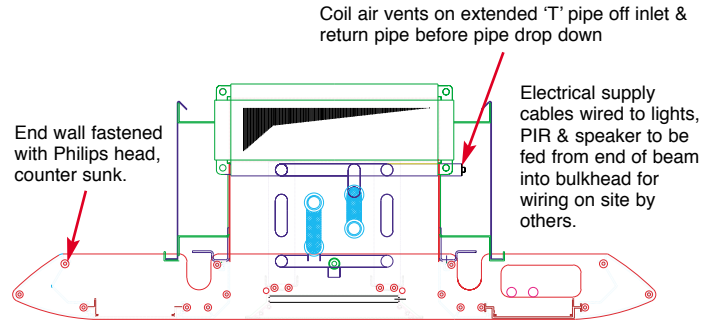

East & West MSCB - end elevation

7.1.1 East & West Elevations

The diagram below shows the interface at the central bulkhead for the 'single' length beams on the East and West façades.

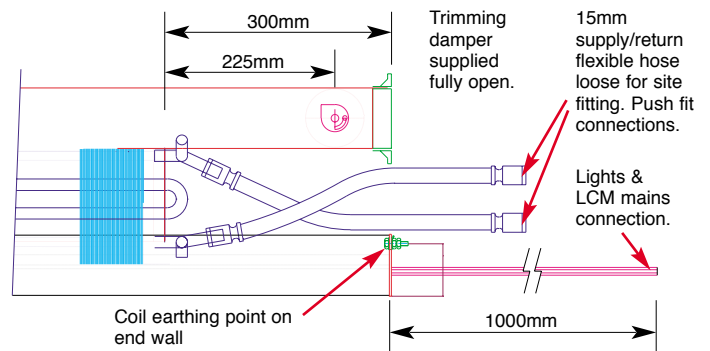

East & West MSCB - side elevation

7.1.2 South Elevation Downstand Beam

The South elevation, due to its orientation and extended floor plate, required additional cooling. This is provided in the form of a double length beam, which extends beyond the line of the existing structure. The existing structure incorporated a ring beam at window head level, which has been retained. At this point the structural beam is below the level of both the existing and new soffit.

A limited slab to soffit structural height drove the MSCB's to the highest possible position. The detailing at this interface made it necessary to accept the downstand beam, whose position varied to follow the concave façade, thereby requiring a level of flexibility either side of the beam.

The detail was repeated at each MSCB/downstand beam interface (see plan view below), but due to the building tolerances the solution had to satisfy:

- The structural downstand beam width varied around the building façade.
- The MSCB struck at a different cord/angle around the façade.
- The detail must provide flexibility to accommodate varying tolerances on a floor by floor basis.

Multi-Service Chilled Beams

Typical South Elevation - reflected plan view (courtesy of Wilkinson Eyre)

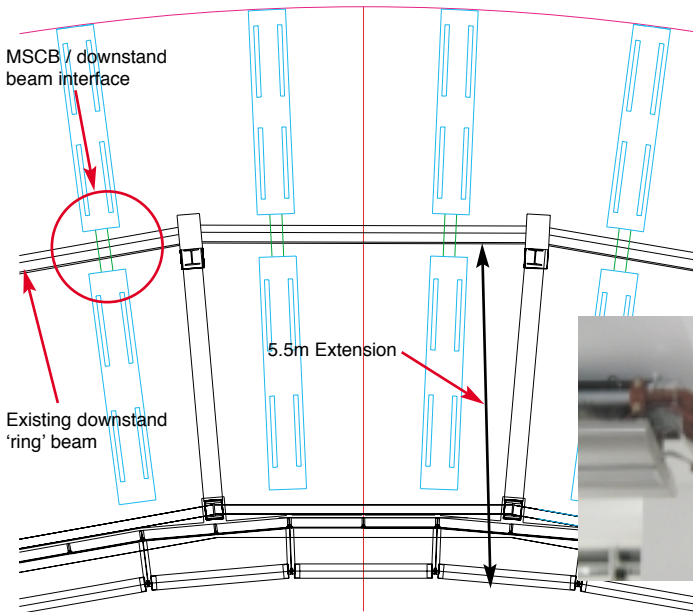

Dummy bridging panel between south elevation MSCB's



Pipework & primary duct set down



Downstand Beam details

The chilled water was supplied to a control section within the southern most beams; connections from this manifold to the coils were made using flexible connections, see detail below.

South MSCB / Downstand beam interface - plan view

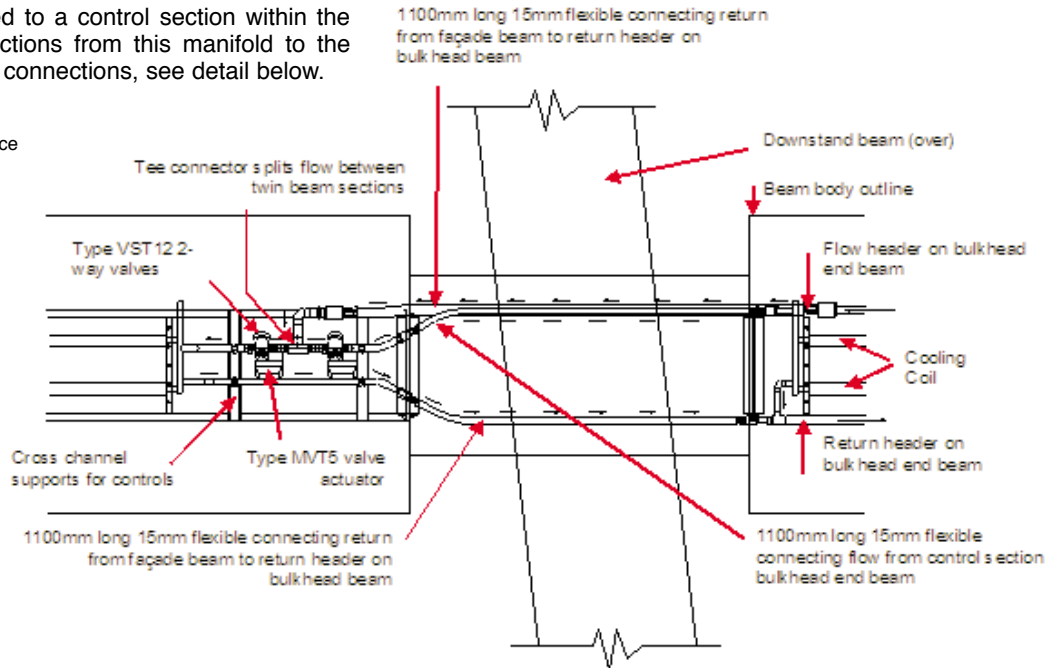

South MSCB / Downstand beam interface - side elevation

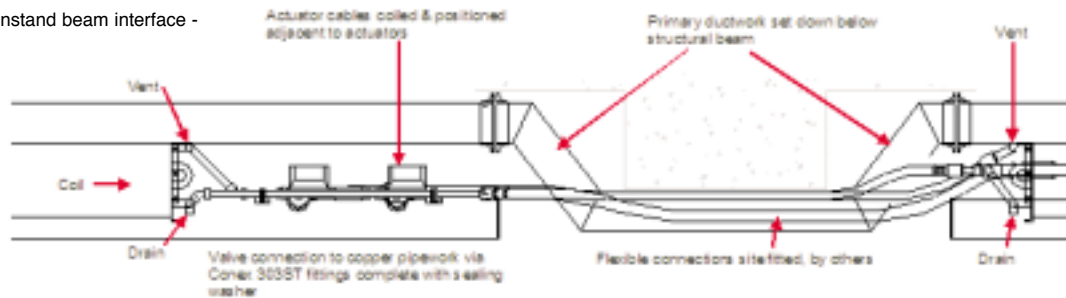

Controls

The MSCB's are controlled with 2-port valves which were mounted within the bulkhead ceiling on the east and west elevations and within a dummy section of the beam on the south elevation. The control valves were site wired to the BMS

outstation, also located in the bulkhead, which monitors room temperature with a return air temperature sensor, located within the MSCB.

Multi-Service Chilled Beams

7.1.3 Cooling Performance - Technical Selection

Prior to laboratory testing, equipment selections are made of the active chilled beams for assessment against design conditions. Full scale laboratory testing commences once preliminary selections and beam design is satisfied.

Equipment performance data schedule for the Trox DID300 active beam

TROX [®] TECHNIK					DID 300 calculation			
Input DID	2 water circuits/cooling + heating		1 water circuit/cooling or heating		Project	room-No.	comment	
	cooling	heating	cooling	heating				
Vwater DID	110 l/h	110 l/h	250 l/h	250 l/h				
Unit length	3000 m							
Nozzle type	b							
Vair-primary DID	169.2 m ³ /h							
No-nozzles active	47.0 l/s							
	96							
Input temperatures	cooling	heating	Input room measures					
	Tair-primary	14.0 °C	18.0 °C	room height				3.0 m
	Troom	24.0 °C	18.0 °C	A				3.0 m
	Twater-flow	14.0 °C	35.0 °C	X				2.5 m
Restore No. off standard active nozzles	Unit primary airflow l/s		Vwater DID = const		layout room-face	Language		
Input DID	2 water circuits/cooling + heating		1 water circuit/cooling or heating		70% - free area	english		
	cooling	heating	cooling	heating	50% - free area			
Δtwater	-5.0 K	6.2 K	-3.0 K	5.1 K				
Twater-return	19.0 °C	28.8 °C	17.0 °C	29.9 °C				
ΔT room - water flow	-10.0 K	17.0 K	-10.0 K	17.0 K				
ΔT Room water average	-7.5 K	13.9 K	-8.5 K	14.4 K				
Qwater DID	-639W	790 W	-879 W	1495 W				
Qair DID	-571W	0W	-571W	0W				
Q DID	-1209W	790W	-1450W	1495W				
ΔP water	3.6KPa	1.2KPa	20.5KPa	18.9KPa				
ΔP air	95.6 Pa							
Lwa	38.5 dB(A)							
vL	0.37 m/s		0.37 m/s		support values			
vH1	0.25 m/s		0.25 m/s		N-active nozzles	96		
ΔTL	-0.88 K		-0.957 K		N-nozzles total	112		
ΔTH1	-0.26 K		-0.28 K		Aeff	0.004825 m		
X-krit	3.2 m		3.1 m		veff	9.74 m/s		
Archimedes-number	0.000196		0.000214		H1	1.3 m		
ΔTsupply	8.1 K		8.8 K		L	3.8 m		

Standard Trox DID300 with known performance characteristics

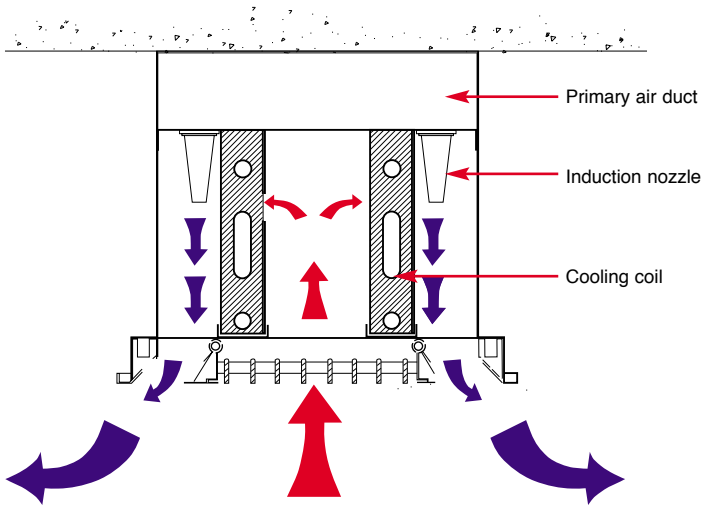

At the centre of the MSCB is a standard active chilled beam whose construction methods are modified to accept an architectural shroud required for mounting other services. The cooling is achieved through a combination of induced air flow and heat exchange across the cooling coils. Primary air is ducted to the beam and discharges out of induction nozzles. The discharge velocity from the nozzle is high relative to a small mass of air. The characteristics and energy of this jet induces warm room air across the cooling coil (which absorbs the heat from the airstream and cools it) and into the primary air stream. Thus, the mass of cool air induced into the primary air stream has the effect of reducing the air stream velocity as it mixes within the plenum chamber prior to discharging from the beam.

7.1.4 Laboratory Testing

Testing was conducted in the Trox (UK) environmental test chamber between December 2000 and January 2001.

7.1.4.1 Acoustic

Indicative measurements to ensure noise criteria of NR38 could be satisfied.

7.1.4.2 Aerodynamic and Environme

- Bull-nose analysis to establish discharge of cooled air up towards concrete soffit to maximise the opportunity for the supply air speed to decay and for the terminal core supply air to room temperature differential to be minimal.
- Interaction with light fitting to ensure air jet re-attached to outer bull-nose.
- Air balance along 4.5m beam length, and double beam length with centre set down section.
- Interaction with low level perimeter heating to ensure heating dealt effectively with any draught from glazing.
- Pressure and volume control damper assessment to provide on site commissioning data.

7.1.4.3 Pre-testing evaluation of bull-nose/ slot aerodynamics

Preliminary aerodynamic tests were conducted on the outer edge profile to ascertain the boundaries of radii that could be considered by the Architect when defining the outer shape of the MSCB. It is important that a gentle curve is maintained so the attachment of the discharging air stream through 'coanda' effect projects the cool air upwards to the exposed soffit. The discharge characteristics ensure that the optimum temperature and velocity decay is achieved to ensure maximum comfort within the occupied zone.

Multi-Service Chilled Beams

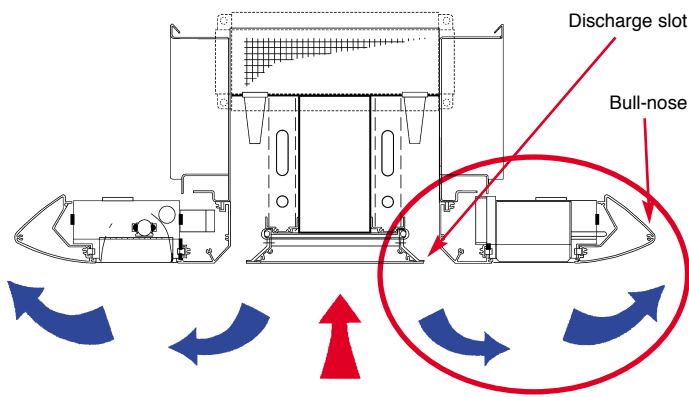

Design Cooling Summer - 2 No. Beams

Air Flow/beam - 59 l/s
 Supply Air - 15.5°C
 Room Air - 24°C
 Water Flow - 319 l/h
 Supply Water - 14°C
 Total Cooling - 3472 W

Design Cooling Winter - 2 No. Beams

Air Flow/Beam - 59 l/s
 Supply Air - 20.5°C
 Room Air - 22°C
 Water Flow - 319 l/h
 Supply Water - 14°C
 Total Cooling - 2400 W

7.1.4.4 Design Data

Room Data	
Test Room Length (m)	7.1
Test Room Width (m)	5.5
Height (m)	2.85
Room Dry Bulb ¹ RDB (Summer)(°C)	24
Room Dry Bulb ¹ RDB (Winter)(°C)	22

Chilled Beam	
Overall Length (m)	4.5
Active Length (m)	4.2
Supply Water Temp. (°C)	14
Supply Air Temp. (Summer) (°C)	15.5
Supply Air Temp. (Winter) (°C)	20.5
Volumetric Flow Rate Air (per beam) (l/s)	59
Volumetric Flow Rate Water(per beam) (l/h)	319

Cooling Duty	
Duty required per beam (Summer)	1700W
Duty required per beam (Winter)	1200W

7.1.4.5 Environmental Testing

Tests were conducted to prove the beam's performance in two conditions, maximum summer cooling and winter cooling. Studies were conducted to assess temperature and velocity profiles within the space. The target maximum terminal speed within the space was 0.25m/s, and maximum temperature gradient limited to a maximum of 3.0K in order to achieve good comfort. Test results successfully demonstrate compliance with these pre-determined criteria.

Thermal performance from the combined ventilation and heat exchange process utilised by the beam ensured that cooling capacity of the beams achieve design conditions.

Curved face beam tests



Flat faced MSCB in test laboratory



Description of test	Max summer cooling	Winter cooling with radiators on
Primary supply air vol. l/s/m	0.23	0.21
Ave Local Speed (m/s)	0.17	0.13
Minimum local temp. (°C)	23.1	21.3
Maximum local temp. (°C)	24.3	22.9

Description of test	Summer cooling	Winter cooling
Max local Speed (m/s)	14	14
Chilled Beam Nozzle type	8mm dia.	8mm dia.
Room temp. (°C)	24	22
Coil Cooling (watts)	1128	840
Coil Cooling (watts)	269	200

Multi-Service Chilled Beams

Laboratory air temperature and speed room scan

PROJECT REFERENCE : EMPRE 88 HOUR
 CLIENT : THE IHS PARTNERSHIP
 TEST REFERENCE - W8 071
 ROOM CONDITIONS AS TROX SUMMER CONDITION TEST PROPOSAL
 RADIATOR SURFACE TEMPERATURE = AMBIENT TEMPERATURE OF ROOM

page 1.

TROX[®] TECHNIK
 AIR DISTRIBUTION LABORATORY
 29th DECEMBER 2001

TEST RESULTS

LEFT BEAM
 WATER FLOW 310 L/hour SUPPLY TEMPERATURE 12.9 Deg C RETURN TEMPERATURE 15.6 Deg C 991 W
 AIR SUPPLY VOLUME 50 L/sec SUPPLY TEMPERATURE 15.5 Deg C EXTRACT TEMPERATURE 23.1 Deg C 553 W

RIGHT BEAM
 WATER FLOW RIGHT BEAM 310 L/hour SUPPLY TEMPERATURE 13.1 Deg C RETURN TEMPERATURE 15.6 Deg C 982 W
 AIR SUPPLY RIGHT BEAM 50 L/sec SUPPLY TEMPERATURE 15.5 Deg C EXTRACT TEMPERATURE 23.1 Deg C 552 W

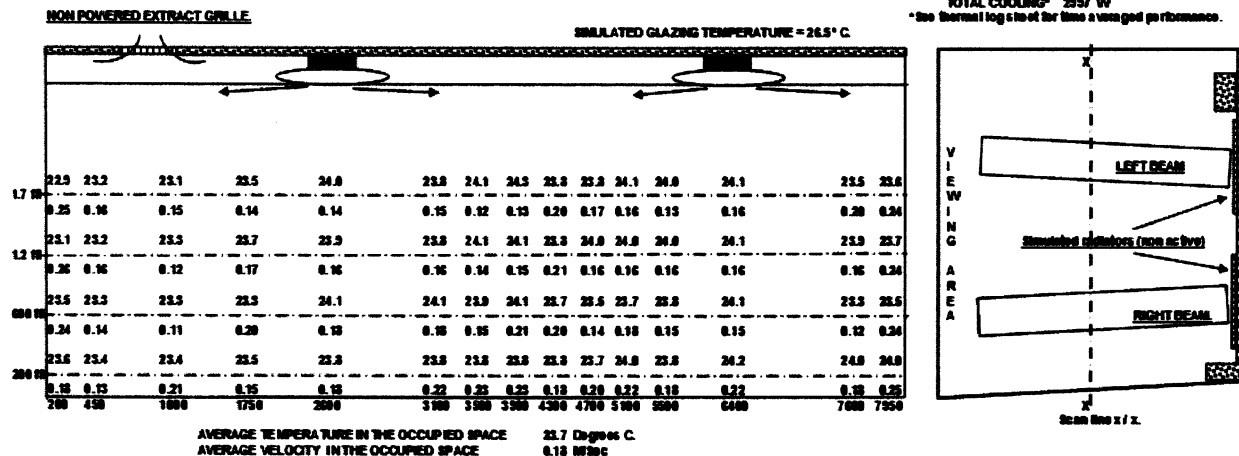

Exposed active MSCB air distribution pattern

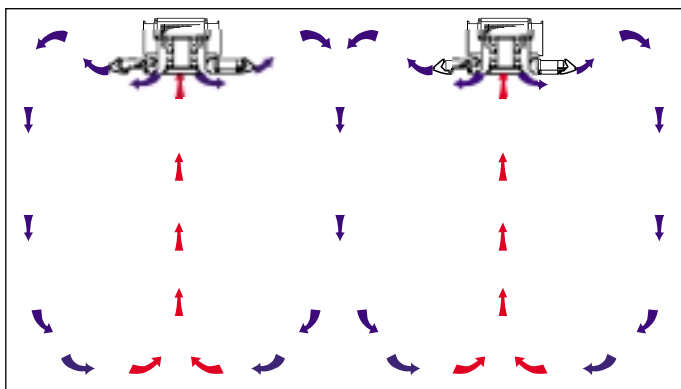

PMV can be obtained by:

1. An equation requiring a computer program because of the need for an iterative solution.
2. Direct measurement, using an integrating sensor.
3. Using tables of PMV for different combinations of activity, clothing level, operative temperature and relative air velocity to be selected.

When the PMV value has been determined the PPD can be determined from the equation

$$PPD = 100 - 95 \times e^{-(0.3353 \times PMV^4 + 0.2179 \times PMV^2)}$$

Thermal comfort assumptions

Description	Value
Activity level	Sedentary activity (office) 1.2 met
Clothing level	Light office wear 0.75
Humidity	This is not controlled in the test facility 50% RH

Summary Table

To	22.0° C	23.0° C	24.0° C
Tair_av		23.67° C	
v_av		0.17	
PMV_min	-0.60	-0.33	-0.05
PMV_max	-0.30	-0.05	0.21
PPD_av	9.93%	6.05%	5.15%

Definitions:

CLO	in met	Clothing level
To	in °C	Operative temperature
Tair_av	in °C	Average room air temperature
v_av	in m/s	Average room air velocity
PPD_av	in %	Average predicted percentage of dissatisfied
PMV_min	-	Minimum predicted mean vote
PMV_max	-	Maximum predicted mean vote

7.1.4.6 Thermal Comfort

The design of the MSCB must ensure that the environmental design requirements are being achieved, it is also vital that a suitable level of thermal comfort is satisfied. The exposed MSCB was tested in the Trox UK test chamber and assessed against the following PMV and PPD criteria.

The model in BS EN ISO 7730:1995 is used.

The model uses the predicted mean vote (PMV) index which combines the influence of temperature, air movement and humidity with clothing and activity level into one value on a 7-point thermal sensation scale, from hot (+3) to cold (-3).

The predicted percentage of dissatisfied (PPD) index provides information on thermal dissatisfaction by predicting the percentage of people likely to feel too hot or too cold in a given environment.

Multi-Service Chilled Beams

Conclusion

The summary table above shows that with an operative temperature of 24°C a reduced rate of dissatisfaction and consequently an even higher level of comfort can be achieved than at 22°C.

7.1.4.7 Aerodynamic optimisation

The face of the beam was refined to ensure the aesthetic requirements along with the necessary airflow characteristics were satisfied, the diagrams below detail the bull-nose and light fitting's impact on air flow.

Airflow pattern with 'open' light fittings

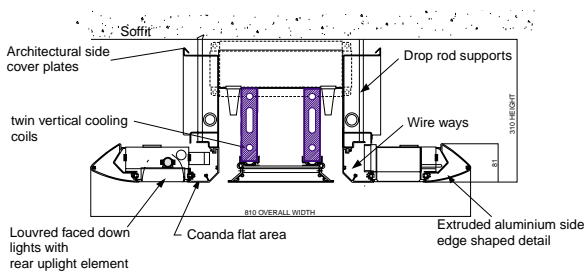

The illustration details the air pattern when the light fitting is open at the top and bottom, eg. no light spill reflector or lamp shroud, allowing room air to be induced into the supply air jet across the fitting causing the jet to become unstable and detach from the face of the beam. The result will cause the air to dump into the occupied zone prematurely at an excessive speed and high cooling differential.

Airflow pattern with 'steep' bullnose

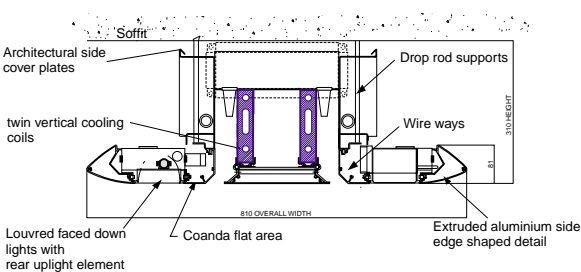

The illustration details the air pattern that results when the discharge velocity from the supply air jet coupled with a high cooling differential are insufficient to maintain the 'coanda' effect required to project the supply air upwards in the direction of the soffit. In this instance a maximum incline tangent of 22° was established.

Optimum Airflow pattern

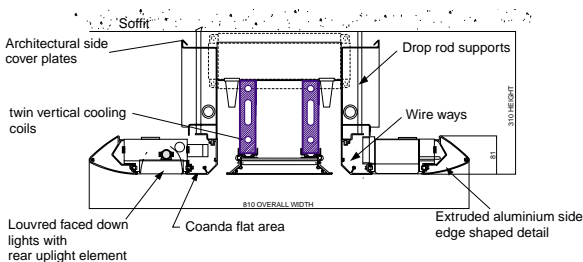

The illustration details the optimum air flow pattern that demonstrates the balance between aesthetic requirements and the beam discharge characteristics. The resulting air flow pattern achieves the maximum comfort in the space. The air is discharged upwards to the slab, not directly into the user space, which ensures the supply air velocity and temperature decay successfully.

7.2 Lighting & Lighting Control Modules

The light fittings and lighting control systems were provided by Luxonix and Home Automation, respectively. Luxonix pre-addressed the light fittings at works prior to delivery to the Trox factory. Lighting control modules were pre-programmed by 'Home Automation' and supplied to Trox for fitting.

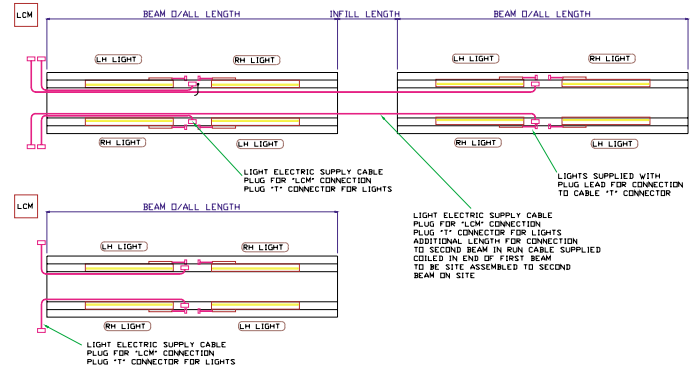

Asymmetric Light Fitting

The beam spacing required the lighting manufacturer (Luxonix) to develop a specific reflector to provide the required level of lighting in the office space.

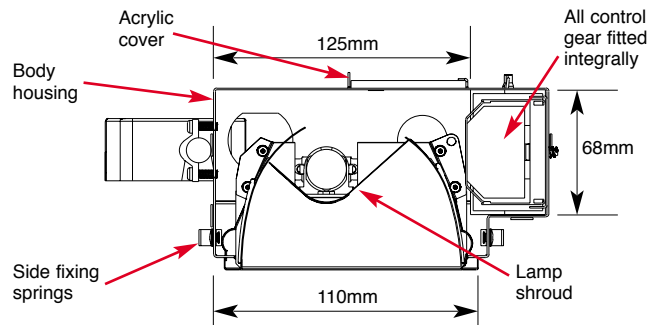

Down + Uplighting - with 'wash' on soffit. A simple reflector was used to direct light spill from the top of the light fitting to provide visual interest on the soffit.

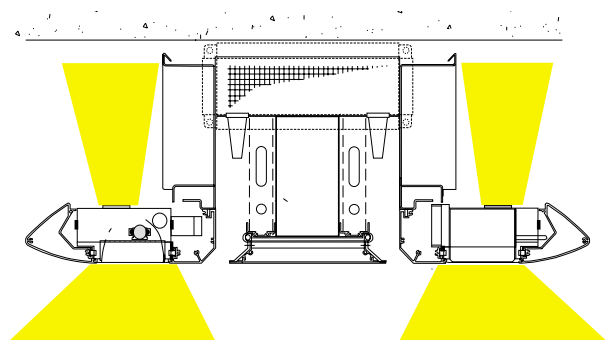

7.2.1 Lamp Shroud

To maintain the working temperature of the low energy T5 lamp at its optimum 35° C, a lamp shroud has been introduced within the louvre. The impact of the cool air discharged from the slot on lamp temperature is minimised ensuring the two components combine effectively.

7.2.2 Lighting Design

A high frequency dimmable 35watt T5 lighting solution was selected for maximum energy efficiency. Luxonic conducted photometric tests in an ISO standard test chamber on lighting performance to confirm that the fittings provide the design lighting level.

Glare rating test results
- courtesy of Luxonic

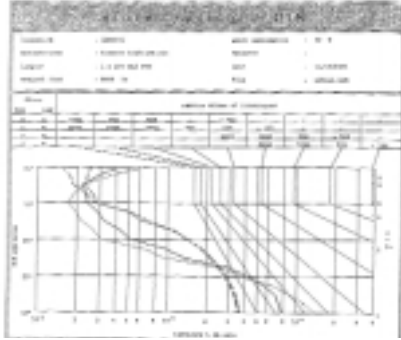

Intensity distribution test results - as provided by Luxonic



7.2.3 Design requirements

Lighting level: 400 lux maintained illuminance at the working plane.
Glare index: 19.

In addition to the base design performance requirements, the lighting solution also needed to satisfy the following:

- LG3 compliance.
- Lighting levels met with splayed spacing of beams, see diagram below.
- Uplighting component to provide visual interest on the soffit.

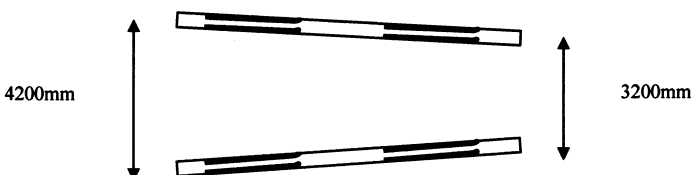

7.3 Emergency Light Fittings

Should power to the floors be lost, the emergency lighting is required to aid safe evacuation from the building. Space has been allowed in the beam design to accommodate emergency battery packs to support selected light fittings. Pre-designated units were installed during the manufacture of the beams, but additional battery packs can be retro-fitted to the installed units should the needs of the building change over time.

7.4 PIR Detectors

The profile of the PIR detector was carefully selected to ensure that a flush mounted detail was achieved with the aluminium extrusion.

The detectors used are multi-functional carrying out the following tasks:

- To monitor the ingress of daylight and automatically dim the light level of the fittings to maintain the required luminance level.
- To sense movement of personnel within the workspace and thus 'power-up' the fittings from their energy saving 'sleep' mode.
- To sense 'heat' from stationary people within the workspace and maintain lighting level.

Once installed on-site the PIR device is set-up to 'learn' brightness levels to enable the correct control signal to be sent to the luminaries. Future MSCB projects may take advantage of a factory pre-test to enable this 'burning in' process to be completed prior to the MSCB's site installation speeding up commissioning times.

PIR detector



Multi-Service Chilled Beams

Details of the PIR detector and MSCB interface

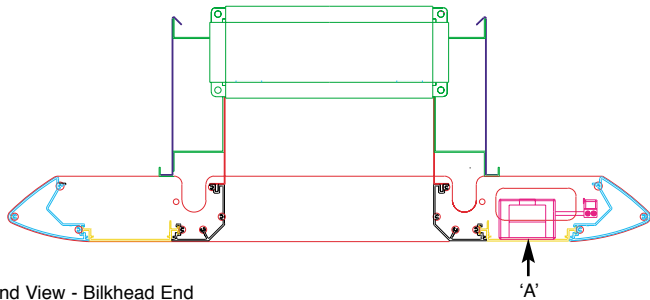

End View - Bulkhead End

Natural anodised speaker + fire rated cable

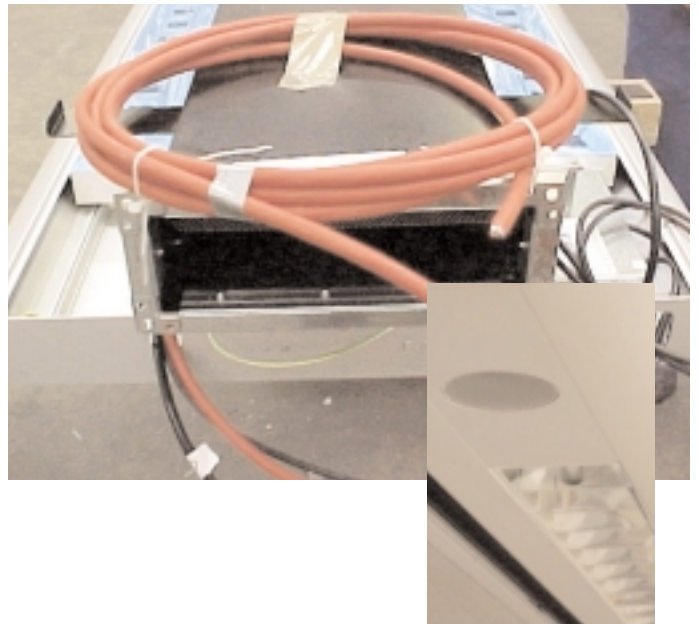

Detailing of rear mounted speaker and beam interface

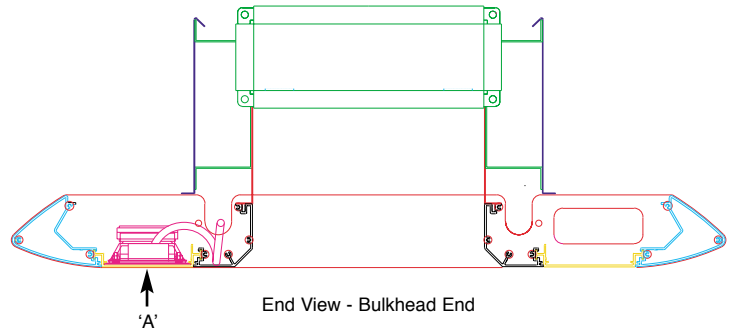

End View - Bulkhead End

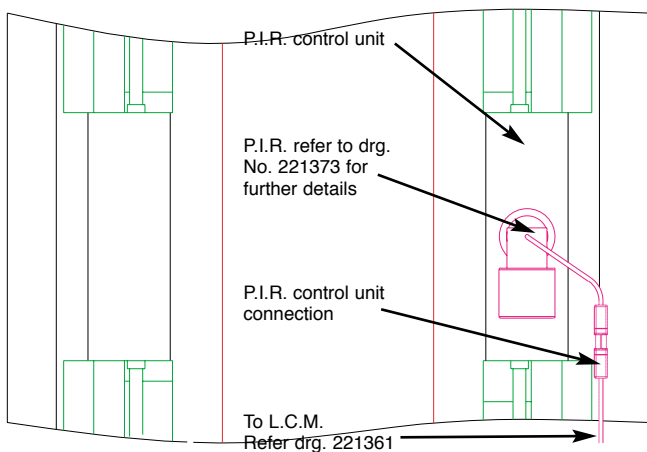

Plan View - Beam Centre

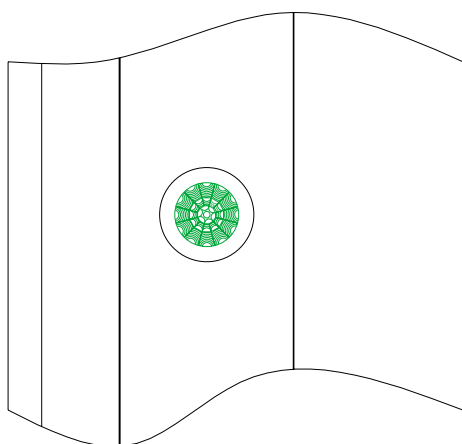

View 'A'

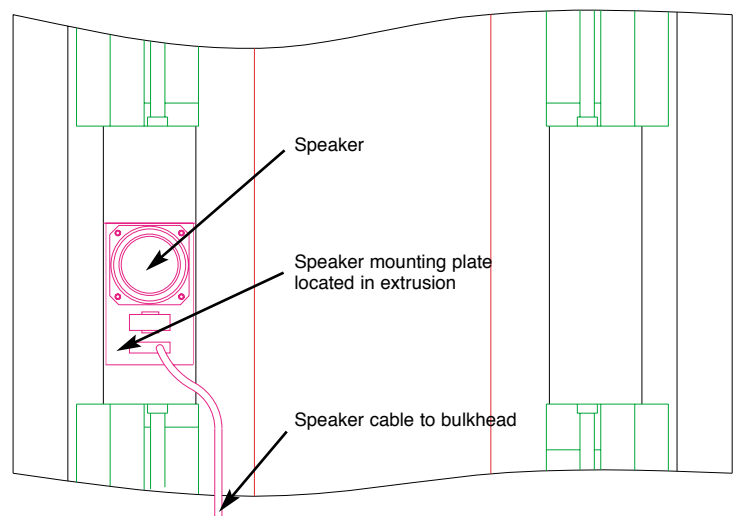

Plan View - Beam Centre

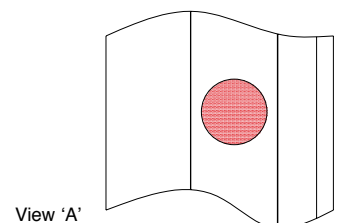

View 'A'

7.5 Public address / voice alarm speakers (PA/VA)

The PA/VA speakers and flying lead were supplied to Trox by the electrical contractor for factory fitting into pre-formed apertures within the beam extrusion. The speaker is part of the fire evacuation system and therefore the cabling is a fire rated grade.

7.6 Sprinkler Pipework

The beam design accommodates the sprinkler range pipework, which was incorporated into the design at a relatively late stage in the project. Although integration within the beam face may have been possible, an extended on-site construction program would have resulted and therefore a decision was taken to locate the sprinkler heads in between the beams. The main feeder pipework, although site installed, is still contained within the chilled beam profile.

Cross section through MSCB and Sprinkler

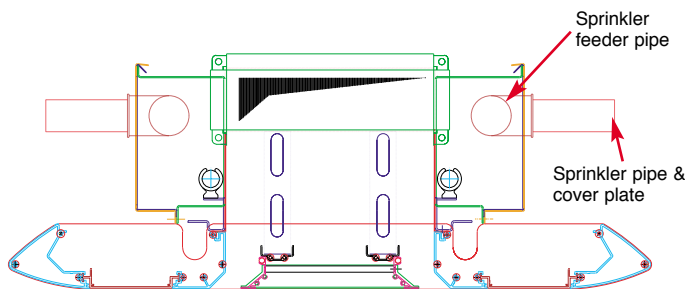

Side elevation of MSCB and sprinkler heads

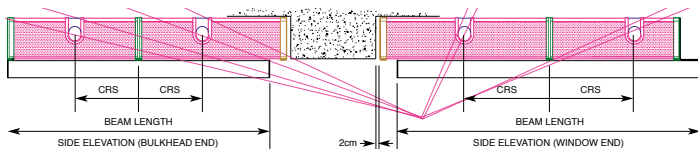

8.0 Tenant Flexibility

The brief required that the space should be able to be used as open plan office, but with the flexibility to allow a high degree of cellular partitioning to provide private offices or meeting room areas. It is widely accepted that fan coil units provide a high degree of flexibility in this regard and therefore the MSCB also needed to meet this requirement. The design of the beams has been developed to accommodate the introduction of partitions so that the space may be subdivided at the centre of each structural bay. Each beam is complete with its own control valve and by the addition of a new sensor to the new zone and wiring back to the floor outstation, each space can have individual comfort control.

If the depth of the cellular office to be formed is less than the length of the chilled beam, then the partition may cross the beam, but it will require adaptations to allow for proper maintenance and the desired level of acoustic separation.

A typical fit out procedure would be as follows:

- The beam return air grille is modified to suit the partition position and 'infill' piece added to allow the partition to fit to the beam.
- The control sensor is moved or added and wiring amended so that the main area has control over its comfort conditions.
- The partition should be formed with path for return air. This may include an acoustic attenuator depending on acoustic separation requirements.
- New luminaries are added to existing luminaries adapted to suit the space formed.
- Adapt sprinklers as required.

Integral Partition Interface Detail

The details below are applicable for necessary modifications when the cellular office is less than the beam length.

Return air face removed & infill piece inserted.

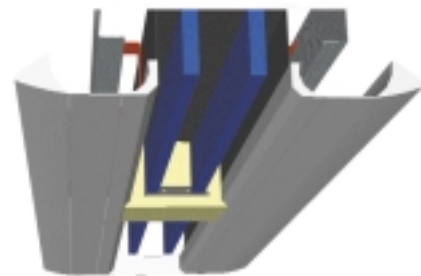

Return air face in 2 pieces installed either side of infill.

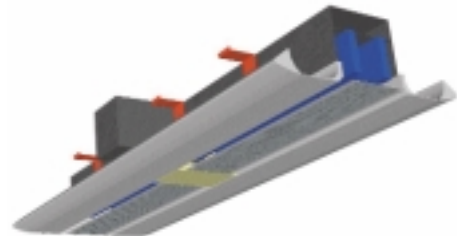

Wrap around shroud to ease partition interface in place.

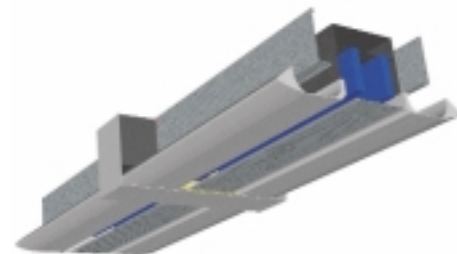

9.0 Manufacturing

Off-site prefabrication enables a consistent high quality product to be achieved within a controlled environment. Pre-delivery testing reduces commissioning time on site. As with on-site programming, logistics control and management it is essential to ensure that components are received and ready for use at the correct time during the manufacturing process. The following flowchart identifies the various key stages of manufacture.

Multi-Service Chilled Beams

Production, Logistics, Quality Control and Pre-Delivery Testing Process

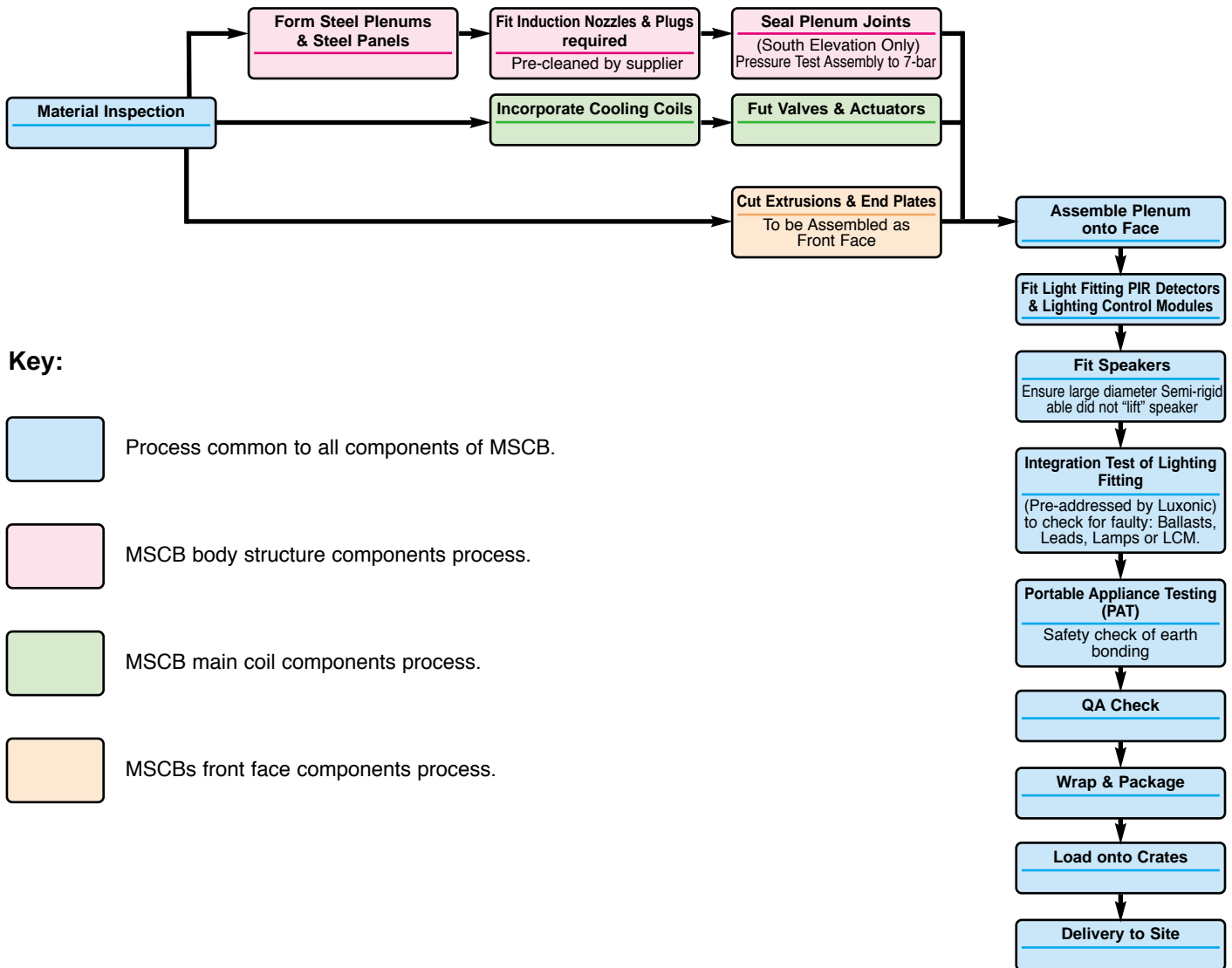

MSCB Manufacturing Variations

The MSCB design required a flexible manufacturing system that could accommodate sixty unique beam types, any combination of each type were required on a floor by floor basis. There are fifteen different beam lengths/types to suit the east and west elevations beams, and the southern internal and southern façades beams. Each type has four alternative services arrangements A to D (see table below).

Services Options	Services Arrangement			
	A	B	C	D
Lighting	√	√	√	√
Emergency lights	√	x	√	x
PIR sensors	√	√	√	√
PA/VA speaker	√	√	√	√
Return air sensor	√	√	x	x
Cooling coil	√	√	√	√
Fresh air	√	√	√	√

Multi-Service Chilled Beams

10.0 Installation

- With pre-fabrication at works the beam design ensured maximum efficiencies for the contractor on site. Setting out positions were pre-determined by the location of the uni-strut crossbar supports. The beams, once removed from their returnable wooden crates, were lifted into position using hydraulic lifting units and bolted to the uni-strut. Levelling was achieved with lasers.

Slotted holes within the fixings enable movement and adjustment in all directions.

The deflection of the concrete soffit required the fixing details to be designed to ensure that the beams protrusion into the space is kept to an absolute minimum.

The MSCB's arrive on site in protective returnable crates; hydraulic lifting equipment is used to enable the beams to be fixed to the slab. Scaffolding platforms allow easy access to the installed unit.

Hydraulic Hoist



MSCB in returnable timber crates



Scaffolding to access beam services

Multi-Service Chilled Beams

10.1 Onsite Program comparison MSCB and FCU

The project utilises fan coil units on the three new floors at the top of the building, the 14th floor and part of the first floor. Exposed multi-service chilled beams were used on the

remaining 24 floors. A true comparison of the fitting out program for each system has therefore been possible and is shown below.



Programme data courtesy of Bovis Lend Lease

Empress State Building

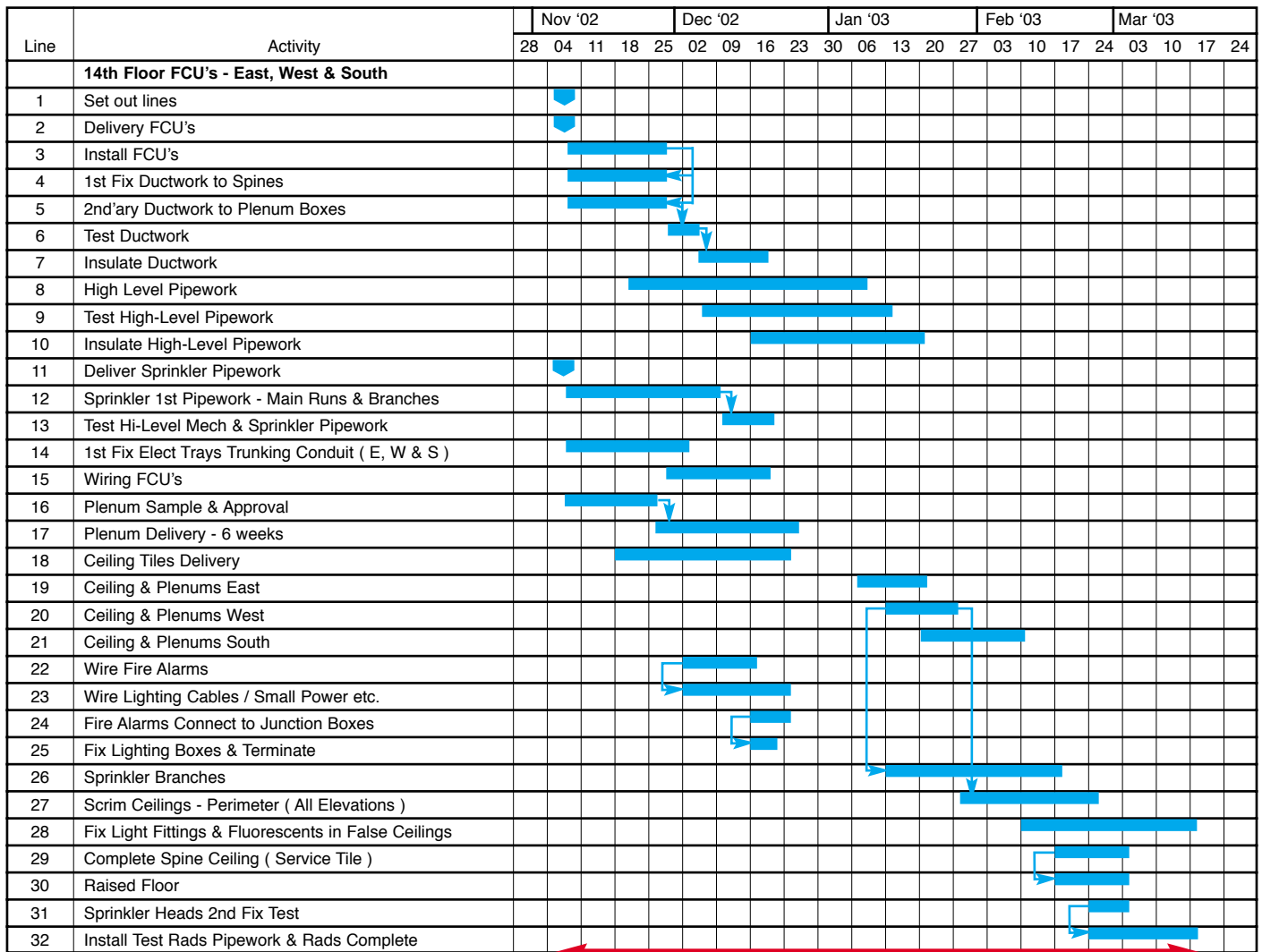

Multi-Service Chilled Beams

Empress State Building

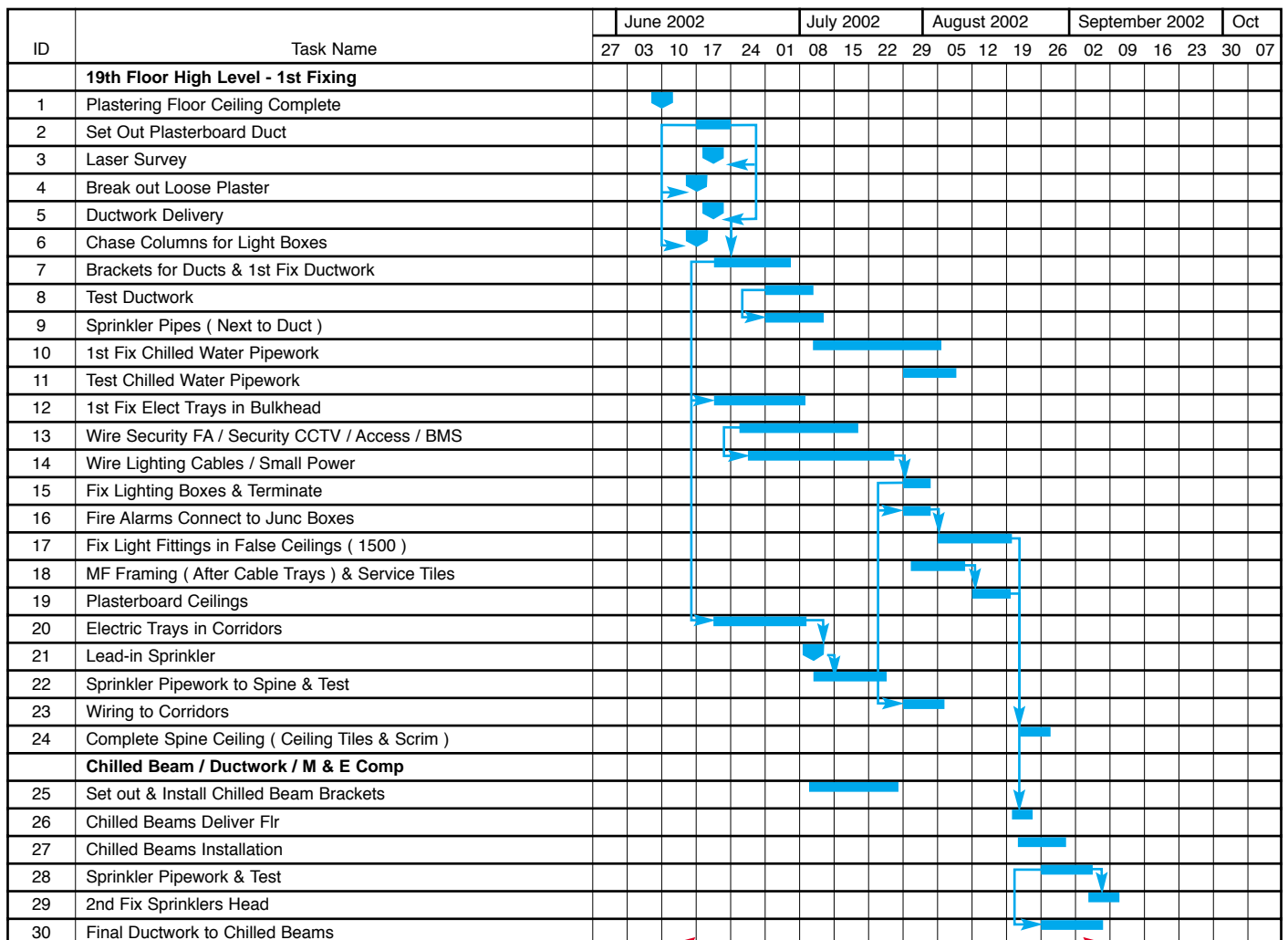

MSCB floor services installation: 12 weeks

11.0 Procurement

The project cost manager, EC Harris on behalf of Land Securities, following a competitive pre-tendering exercise placed the instruction for the supply of the MSCB's with Trox. This was based on an outline design for a typical floor produced by the services design team, MG Partnership and BWS consulting engineers.

11.1 Capital Expenditure

Twenty-four of the existing twenty-seven floors use the MSCB solution. A capital cost summary for a typical floor is shown below:

Item	Check list / Cost
MSCB	√
Scrim to Soffit	x
Flow/return pipework (on south elevation MSCB)	√
Control valves and actuators* (on south elevation MSCB)	√
Light fittings and cables	√
Lighting Control Modules *	√
Provision for sprinkler pipework	√
P.I.R Detectors *	√
P.A / V.A Speakers *	√
Cost, including package management and installation	£133,118.00
Net floor area	1401 m ²
MSCB cost per m ²	£95.02/m ²

* Note: The cost of these items includes for fitting only

12.0 Summary

The refurbishment of this 415,000ft² 1960's building has presented many challenges to each of the construction disciplines. The project achieved practical completion on programme (18 months) and on budget in April 2003. The following quotes are a testament to the success of the project and the important contribution made by the use of MSCB :

Land Securities
John Anderson
(Development Director)

"Architects and engineers have successfully combined to recycle this low height structure with an exposed soffit and multi-service chilled beams".
"To demolish and re-build would have extended the programme by 2 years with lost revenue in the order of £24 million."

Neill Pennell
(Engineering Director)

"Land Securities aim to increase the portfolio of Landflex accommodation across London to 1.5 Million ft² in the medium term and we will whenever possible use innovative services solutions like Multi-Service Chilled Beams which combine flexibility with capital cost efficiency and lower life cycle costs in these buildings".

Simon Whitelock
(Project Manager)

"A customised Multi-Service Chilled Beam solution was achieved through collaboration between the professional team and the Trox R&D design bureau."

Bovis Lend Lease
Darryl Hpa
(Building Services Director)

"Programme and pre-fabrication benefits of MSCB's assist the construction process by offering programme and cost certainty".
"Multi-Service Chilled Beams enabled the construction programme to be markedly reduced".

Wilkinson Eyre
Paul Baker
(Lead Architect)

"The elegant lines that may be achieved through the combination of a customised design and aluminium finish (of the MSCB) contribute to the lightness of the product enhancing the office space."

Ed Holloway
(Architect)

"Multi Service Chilled Beams maximised the existing floor to ceiling height, creating an optimised volume for the end user."

MG Partnership
Chris Gaines
(Mechanical Services Consultant)

"The system (MSCB) provides a solution with low running and maintenance costs that requires only limited access to the user space".
"Engineering is combined effectively with the business model for the building by accelerating the time to market".

13.0 Acknowledgements

The authors acknowledge the following for their assistance and contribution to this paper:

Land Securities
- Simon Whitelock
- Mike Varney

MG Partnership (Mechanical Consultant)
- Chris Gaines

EC Harris (Cost Consultants)
- Roger Simpson

Wilkinson Eyre (Architects)
- Paul Baker
- Ed Holloway

BWS (Electrical Consultant)
- Colin Brown

Bovis Lend Lease (Construction Manager)
- Darryl Hpa

14.0 Authors:

Guy Hutchins
Marketing Manager - Trox Design Bureau
Caxton Way,
Thetford,
Norfolk,
IP24 3SQ

Neil Pennell
Engineering Director - Land Securities PLC
5 The Strand
London,
WC2N 5AF

TROX[®] TECHNIK

Trox (UK) Ltd.
Caxton Way
Thetford
Norfolk IP24 3SQ

Tel: +44 (0)1842 754545
Fax: +44 (0)1842 763051
www.troxuk.co.uk
e-mail@troxuk.co.uk